

Original Issue
Dated August 2003
Publication Number 36100009

1.6L

INDUSTRIAL ENGINE SERVICE MANUAL



Vortec 1600
2003 1.6L I4
Industrial Engine



Table Of Contents

General Information	Section 0
Engine Mechanical	Section 1
Engine Cooling	Section 2
Engine Electrical	Section 3

No part of this publication may be reproduced without the written permission of Power Solutions, Inc. At the time of publication, all of the information included in this publication is accurate to the best of our knowledge. Power Solutions, Inc., cannot be responsible for information that has changed after this book was published.

Section 0

General Information

Fastener Notice	0-2	Oil Filter	0-16
General Information - 1.6L	0-3	Engine Air Cleaner	0-16
Conversion - English/Metric	0-3	Safety Element	0-16
Equivalents - Decimal and Metric	0-3	Cooling System Maintenance	0-16
Arrows and Symbols	0-4	Coolant Level	0-16
Engine ID Location	0-5	Radiator	0-17
Fasteners	0-5	Radiator Hoses	0-17
Metric Fasteners	0-5	Fan Belts	0-17
Fastener Strength Identification	0-6	Serpentine Belt	0-17
Prevailing Torque Fasteners	0-7	V-Type Belt	0-17
Prevailing Torque Specifications (Metric)	0-8	Fuel Delivery System Maintenance	0-17
Prevailing Torque Specifications (English)	0-8	Fuel Filter Replacement	0-17
Thread Inserts	0-9	Carbureted Engines	0-17
Abbreviations and Their Meanings	0-9	TBI Engines	0-17
Maintenance and Lubrication	0-15	Zenith Z.E.E.M.S TBI Fuel Injection	0-17
Initial Start Up Maintenance	0-15	Ignition Systems	0-18
Routine Maintenance	0-15	Types of Ignition Systems	0-18
Scheduled Preventive Maintenance	0-15	Ignition Timing	0-18
Engine Oil Level Check	0-15	Spark Plugs	0-18
Adding Engine Oil	0-15	Maintenance Schedule - 1.6L Engine	0-19
Engine Oil and Filter	0-15	Approximate Fluid Capacities	0-19
Engine Oil Quality	0-15	Filter Chart - 1.6L Engine	0-20
Engine Oil Recommendation	0-16		

Fastener Notice

NOTICE: Always use the correct fastener in the proper location. When you replace a fastener, use **ONLY** the exact part number of that application.

UNLESS OTHERWISE SPECIFIED, Do Not use supplemental coatings (paints, greases or other corrosion inhibitors) on threaded fasteners or fastener joint interfaces. Generally, such coating adversely affect the fastener torque and the joint clamping force, and may damage the fastener.

When you install fasteners, use the correct tightening sequence and specifications.

Following these instructions can help you avoid damage to parts and systems.

General Information - 1.6L

Conversion - English/Metric

English	Multiply / Divide by	Metric
Length		
in	25.4	mm
ft	0.3048	m
yd	0.9144	m
mi	1.609	km
Area		
sq in	645.2	sq mm
sq in	6.45	sq cm
sq ft	0.0929	sq m
sq yd	0.8361	sq m
Volume		
cu in	16,387.0	cu mm
cu in	16.397	cu cm
cu in	0.0164	L
qt	0.9464	L
gal	3.7854	L
cu yd	0.746	cu m
Mass		
lb	0.4536	kg
ton	907.18	kg
ton	0.907	tonne (t)
Force		
kg	9.807	newtons (N)
oz	0.2780	newtons (N)
lb	4.448	newtons (N)
Acceleration		
ft/s ²	0.3048	m/s ²
in/s ²	0.0254	m/s ²
Torque		
lb in	0.11296	N•m
lb ft	1.3558	N•m
Power		
hp	0.745	kW
Pressure (Stress)		
inches of H ₂ O	0.2491	kPa
lb/sq in	6.895	kPa
Energy (Work)		
Btu	1055.0	J (J= one Ws)
lb ft	1.3558	J (J= one Ws)
kW hour	3,600,000.0	J (J= one Ws)
Light		
Foot Candle	10.764	lm/m ²

Conversion - English/Metric (cont'd)

English	Multiply / Divide by	Metric
Velocity		
mph	1.6093	km/h
Temperature		
(°F-32) / 1.8	=	°C
°F	=	(°C X 1.8) + 32
Fuel Performance		
232.215/mpg	=	L/100 km

Equivalents - Decimal and Metric

Fraction (in)	Decimal (in)	Metric (mm)
1/64	0.015625	0.39688
1/32	0.03125	0.79375
3/64	0.046875	1.19062
1/16	0.0625	1.5875
5/64	0.078125	1.98437
3/32	0.09375	2.38125
7/64	0.109375	2.77812
1/8	0.125	3.175
9/64	0.140625	3.57187
5/32	0.15625	3.96875
11/64	0.171875	4.36562
3/16	0.1875	4.7625
13/64	0.203125	5.15937
7/32	0.21875	5.55625
15/64	0.234375	5.95312
1/4	0.25	6.35
17/64	0.265625	6.74687
9/32	0.28125	7.14375
19/64	0.296875	7.54062
5/16	0.3125	7.9375
21/64	0.328125	8.33437
11/32	0.34375	8.73125
23/64	0.359375	9.12812
3/8	0.375	9.525
25/64	0.390625	9.92187
13/32	0.40625	10.31875
27/64	0.421875	10.71562
7/16	0.4375	11.1125
29/64	0.453125	11.50937
15/32	0.46875	11.90625
31/64	0.484375	12.30312
1/2	0.5	12.7

Equivalents - Decimal and Metric (cont'd)

Fraction (in)	Decimal (in)	Metric (mm)
33/64	0.515625	13.09687
17/32	0.53125	13.49375
35/64	0.546875	13.89062
9/16	0.5625	14.2875
37/64	0.578125	14.68437
19/32	0.59375	15.08125
39/64	0.609375	15.47812
5/8	0.625	15.875
41/64	0.640625	16.27187
21/32	0.65625	16.66875
43/64	0.671875	17.06562
11/16	0.6875	17.4625
45/64	0.703125	17.85937
23/32	0.71875	18.25625
47/64	0.734375	18.65312
3/4	0.75	19.05
49/64	0.765625	19.44687
25/32	0.78125	19.84375
51/64	0.796875	20.24062
3/16	0.8125	20.6375
53/64	0.828125	21.03437
27/32	0.84375	21.43125
55/64	0.859375	21.82812
7/8	0.875	22.225
57/64	0.890625	22.62187
29/32	0.90625	23.01875
59/64	0.921875	23.41562
15/16	0.9375	23.8125
61/64	0.953125	24.20937
31/32	0.96875	24.60625
63/64	0.984375	25.00312
1	1.0	25.4

Arrows and Symbols

This service manual uses various symbols in order to describe different service operations. You may find some or all of these symbols used in the manual.

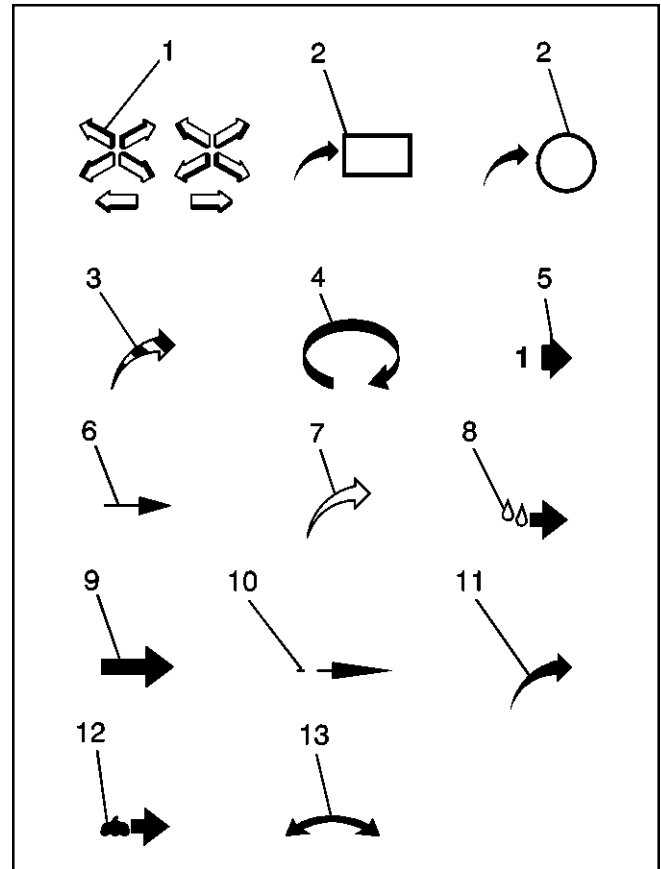

196216

Legend

- (1) Front of Vehicle
- (2) View Detail
- (3) Ambient Air Mixed with Another Gas or Indicate Temperature Change
- (4) Motion or Direction
- (5) View Angle
- (6) Dimension (1:2)
- (7) Ambient/Clean Air Flow or Cool Air Flow
- (8) Lubrication Point - Oil or Fluid
- (9) Task Related
- (10) Sectioning (1:3)
- (11) Gas Other Than Ambient Air or Hot Air Flow
- (12) Lubrication Point - Grease or Jelly

Engine ID Location

To help identify the engine and its serial number, an identification label is affixed to the top of the camshaft housing cover.



80300001

The engine serial number is also stamped into the left side of the cylinder block near the engine flywheel. The stamp contains the engine model number (i.e. 1.6L, 3.0L, 5.7L, etc.) and a serial number which identifies the engine from other GM Powertrain engines provided by Power Solutions, Inc. The engine model and serial number are required when seeking information concerning the engine and/or ordering replacement service parts.



80300002

FASTENERS

Metric Fasteners

The 1.6L engine is dimensioned in the metric system. Most metric fasteners are very close in diameter to well known fasteners in the English, inch system. Replace fasteners with those of the same nominal diameter, thread pitch, and strength.

A number marking identifies the OE metric fasteners except cross-recess head screws. The number also indicates the strength of the fastener material. A Posidrive R or Type 1A cross-recess identifies a metric cross-recess screw. For best results, use a Type 1A cross-recess screwdriver, or equivalent, in Posidrive R recess head screws.

General Motors Engineering and North American Industries have adopted a portion of the ISO-defined standard metric fastener sizes. The purpose was to reduce the number of fastener sizes used while retaining the best thread qualities in each thread size. For example, the metric M6.0 X 1 screw with nearly the same diameter and 25.4 threads per inch replaced the English 1/4-20 and 1/4-28 screws. The thread pitch is midway between the English coarse and fine thread pitches.

The most commonly used metric fastener strength property classes are 9.8 and 10.9. The class identification is embossed on the head of each bolt. The English, inch strength classes range from grade 2 to grade 8. Radial lines are embossed on the head of each bolt in order to identify the strength class. The number of lines on the head of the bolt is 2 lines less than the actual grade. For example, a grade 8 bolt will have 6 radial lines on the bolt head. Some metric nuts are marked with a single digit strength identification number on the nut face.

The correct fasteners are available through PSI. Many metric fasteners available in the aftermarket parts channels are designed to metric standards of countries other than the United States, and may exhibit the following defects:

- Lower strength
- No numbered head marking system
- Wrong thread pitch

The metric fasteners on PSI products are designed to new, international standards. Following are the common sizes and pitches, except for special applications:

- M6 X 1
- M8 X 1.25
- M10 X 1.5
- M12 X 1.75

Fastener Strength Identification

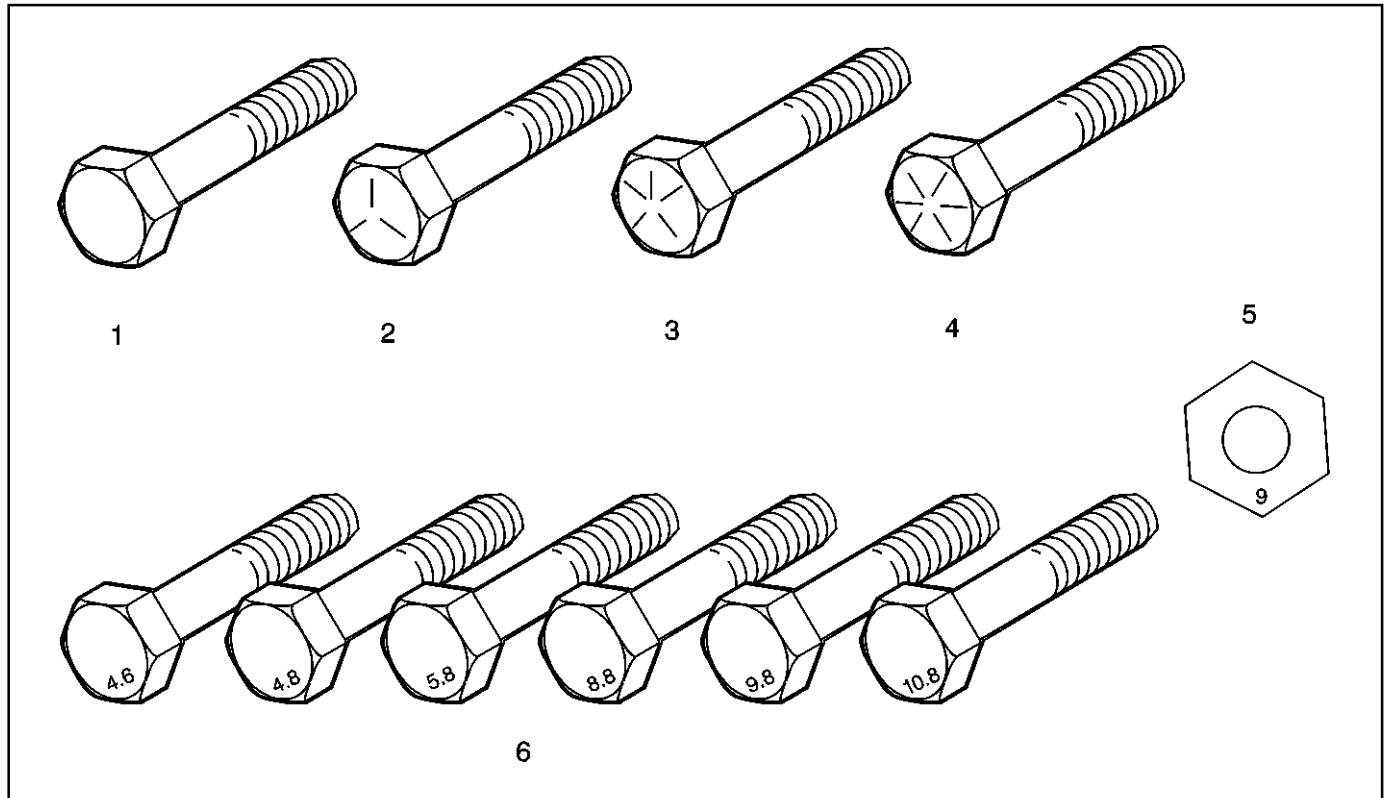

171891

Legend

- | | |
|--|--|
| (1) English Bolt, Grade 2 (Strength Class) | (4) English Bolt, Grade 8 (Strength Class) |
| (2) English Bolt, Grade 5 (Strength Class) | (5) Metric Nut, Strength Class 9 |
| (3) English Bolt, Grade 7 (Strength Class) | (6) Metric Bolts, Strength Class Increases as Numbers Increase |

Prevailing Torque Fasteners

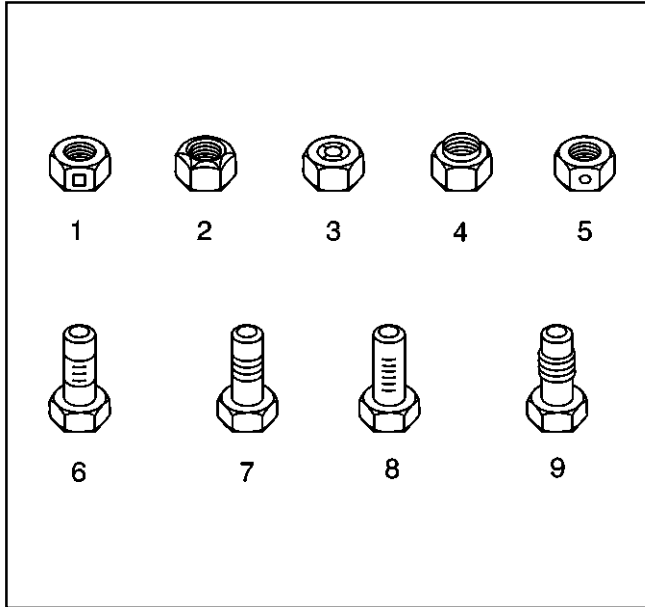

171892

Legend

- (1) Prevailing Torque Nut, Center Lock Type
- (2) Prevailing Torque Nut, Top Lock Type
- (3) Prevailing Torque Nut, Nylon Patch Type
- (4) Prevailing Torque Nut, Nylon Washer Insert Type
- (5) Prevailing Torque Nut, Nylon Insert Type
- (6) Prevailing Torque Bolt, Dry Adhesive Coating Type
- (7) Prevailing Torque Bolt, Thread Profile Deformed Type
- (8) Prevailing Torque Bolt, Nylon Strip Type
- (9) Prevailing Torque Bolt, Out-of-Round Thread Area Type

A prevailing torque nut is designed in order to develop an interface between the nut and bolt threads. Distortion of the top of the metal nut or using a nylon patch on the threads in the middle of the hex flat causes that interface.

A prevailing torque bolt/nut that is clean and free of rust may be reused. If there is any doubt, replace the fastener:

1. Clean away all dirt or foreign material.
2. Inspect the fastener for signs of overtightening.
3. Hand start the fastener at the original location.
4. Inspect the fastener for torque development, referring to the table below.
5. Tighten the fastener within specifications.

Prevailing Torque Specifications (Metric–Size Fasteners)

Application	Specification	
	Metric	English
Nuts and All Metal Bolts/Screws		
6 mm	0.4 N•m	4 lb in
6.3 mm	0.4 N•m	4 lb in
8 mm	0.6 N•m	7 lb in
10 mm	1.4 N•m	12 lb in
12 mm	2.2 N•m	18 lb in
14 mm	3.0 N•m	27 lb in
16 mm	4.2 N•m	37 lb in
20 mm	7.0 N•m	62 lb in
Adhesive or Nylon Coated Bolts/Screws		
6 mm	0.4 N•m	4 lb in
6.3 mm	0.4 N•m	4 lb in
8 mm	0.6 N•m	7 lb in
10 mm	1.2 N•m	11 lb in
12 mm	1.6 N•m	14 lb in
14 mm	2.4 N•m	21 lb in
16 mm	3.4 N•m	30 lb in
20 mm	5.6 N•m	50 lb in

Prevailing Torque Specifications (English–Size Fasteners)

Application	Specification	
	Metric	English
Nuts and All Metal Bolts/Screws		
0.250 in	0.4 N•m	4 lb in
0.312 in	0.6 N•m	5 lb in
0.375 in	1.4 N•m	12 lb in
0.437 in	1.6 N•m	16 lb in
0.500 in	2.4 N•m	21 lb in
0.562 in	3.2 N•m	28 lb in
0.625 in	4.2 N•m	37 lb in
0.750 in	7.0 N•m	62 lb in
Adhesive or Nylon Coated Bolts/Screws		
0.250 in	0.4 N•m	4 lb in
0.312 in	0.6 N•m	5 lb in
0.375 in	1.0 N•m	9 lb in
0.437 in	1.4 N•m	12 lb in
0.500 in	1.8 N•m	16 lb in
0.562 in	2.6 N•m	23 lb in
0.625 in	3.4 N•m	30 lb in
0.750 in	5.2 N•m	49 lb in

THREAD INSERTS

Repair Procedure

Tools Required

General purpose thread repair kits. These kits are available commercially.

Caution: *Wear safety glasses in order to avoid eye damage.*

Important: Refer to the thread repair kit manufacturer's instructions regarding the size of the drill and tap to use.

Avoid any buildup of chips. Back out the tap every few turns and remove the chips.

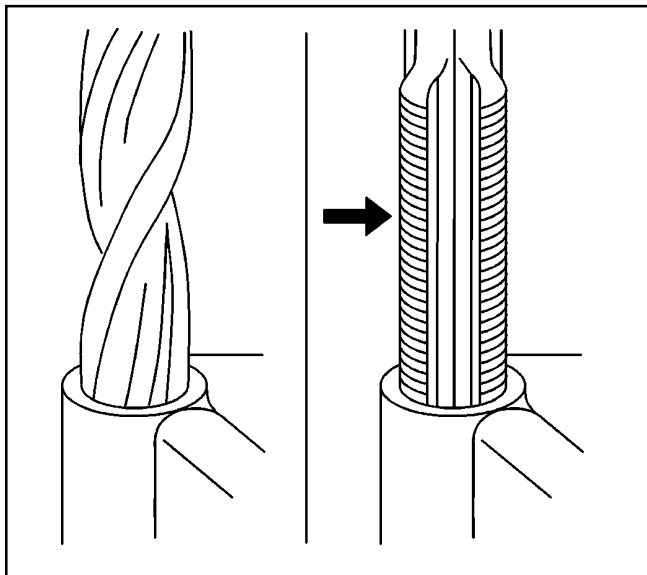

4962

1. Determine the size, the pitch, and the depth of the damaged thread. If necessary, adjust the stop collars on the cutting tool and tap to the required depth.
2. Drill out the damaged threads. Clean out any chips.
3. Lubricate the tap with light engine oil. Tap the hole. Clean the threads.

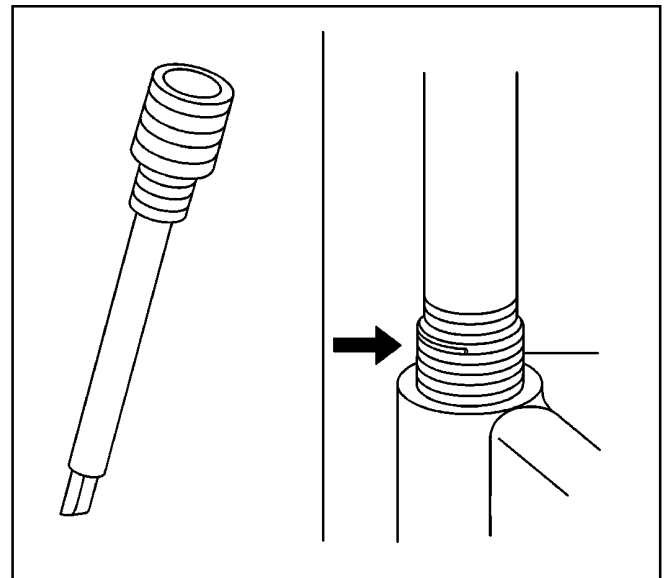

4963

4. Thread the thread insert onto the mandrel of the installer. Engage the tang of the insert onto the end of the mandrel.

Important: The insert should be flush to one turn below the surface.

5. Lubricate the insert with light engine oil, except when installing in aluminum and install the insert.
6. If the tang of the insert does not break off when backing out the installer, break the tang off with a drift.

Abbreviations and Their Meanings

Abbreviation	Meaning
A	
A	Ampere(s)
AC	Alternating Current
ACL	Air Cleaner
AD	Automatic Disconnect
A/D	Analog to Digital
A/F	Air/Fuel (Ratio)

Abbreviations and Their Meanings (cont'd)

Abbreviation	Meaning
APCM	Accessory Power Control Module
API	American Petroleum Institute
APT	Adjustable Part Throttle
ASM	Assembly, Accelerator and Servo Control Module
Auto	Automatic
avg	Average
AWG	American Wire Gage
B	
B+	Battery Positive Voltage
BARO	Barometric (Pressure)
BATT	Battery
BLK	Black
BLU	Blue
BP	Back Pressure
BPCM	Battery Pack Control Module
BRN	Brown
BTDC	Before Top Dead Center
BTM	Battery Thermal Module
C	
°C	Degrees Celsius
Cal	Calibration
Cam	Camshaft
CARB	California Air Resources Board
cm ³	Cubic Centimeters
CCM	Convenience Charge Module, Chassis Control Module
CCOT	Cycling Clutch Orifice Tube CCP Climate Control Panel
CD	Compact Disc

Abbreviations and Their Meanings (cont'd)

Abbreviation	Meaning
CE	Commutator End
CEAB	Cold Engine Air Bleed
cfm	Cubic Feet per Minute
cg	Center of Gravity
CID	Cubic Inch Displacement
CKP	Crankshaft Position
CKT	Circuit
CL	Closed Loop
CLS	Coolant Level Switch
CMP	Camshaft Position
CO	Carbon Monoxide
CO2	Carbon Dioxide
Coax	Coaxial
COMM	Communication
Conn	Connector
CPA	Connector Position Assurance
CPS	Central Power Supply
CPU	Central Processing Unit
CS	Charging System
CSFI	Central Sequential Fuel Injection
CTP	Closed Throttle Position
cu ft	Cubic Foot/Feet
cu in	Cubic Inch/Inches
D	
DAB	Delayed Accessory Bus
dB	Decibels
dBA	Decibels on A-weighted Scale
DC	Direct Current, Duty Cycle
DI	Distributor Ignition
dia	Diameter
DK	Dark

Abbreviations and Their Meanings (cont'd)

Abbreviation	Meaning
DMM	Digital Multimeter
DOHC	Dual Overhead Camshafts
E	
EC	Electrical Center, Engine Control
ECL	Engine Coolant Level
ECM	Engine Control Module, Electronic Control Module
ECS	Emission Control System
ECT	Engine Coolant Temperature
EEPROM	Electrically Erasable Programmable Read Only Memory
EFE	Early Fuel Evaporation
EGR	Exhaust Gas Recirculation
EGR TVV	Exhaust Gas Recirculation Thermal Vacuum Valve
EI	Electronic Ignition
ELAP	Elapsed
E/M	English/Metric
EMF	Electromotive Force
EMI	Electromagnetic Interference
Eng	Engine
EOP	Engine Oil Pressure
EOT	Engine Oil Temperature
EPA	Environmental Protection Agency
EPR	Exhaust Pressure Regulator
EPROM	Erasable Programmable Read Only Memory
ESD	Electrostatic Discharge
ESN	Electronic Serial Number
ETC	Electronic Throttle Control, Electronic Temperature Control, Electronic Timing Control

Abbreviations and Their Meanings (cont'd)

Abbreviation	Meaning
Exh	Exhaust
F	
°F	Degrees Fahrenheit
FC	Fan Control
FDC	Fuel Data Center
FED	Federal (All United States except California)
FEDS	Fuel Enable Data Stream
FF	Flexible Fuel
FI	Fuel Injection
FMVSS	Federal (U.S.) Motor Vehicle Safety Standards
FP	Fuel Pump
ft	Foot/Feet
FT	Fuel Trim
FW	Flat Wire
G	
GA	Gage, Gauge
gal	Gallon
gas	Gasoline
Gen	Generator
GL	Gear Lubricant
GM	General Motors
GM SPO	General Motors Service Parts Operations
gnd	Ground
gpm	Gallons per Minute
GRN	Green
GRY	Gray
H	
H	Hydrogen
H ₂ O	Water
Harn	Harness
HC	Hydrocarbons
H/CMPR	High Compression

Abbreviations and Their Meanings (cont'd)

Abbreviation	Meaning
HD	Heavy Duty
HDC	Heavy Duty Cooling
Hg	Mercury
Hi Alt	High Altitude
HO2S	Heated Oxygen Sensor
hp	Horsepower
Hz	Hertz
I	
IAC	Idle Air Control
IAT	Intake Air Temperature
IC	Integrated Circuit, Ignition Control
ICM	Ignition Control Module
IDI	Integrated Direct Ignition
ign	Ignition
ILC	Idle Load Compensator
in	Inch/Inches
INJ	Injection
inst	Instantaneous, Instant
ISC	Idle Speed Control
ISO	International Standards Organization
K	
kg	Kilogram
kHz	Kilohertz
km	Kilometer
km/h	Kilometers per Hour
km/l	Kilometers per Liter

Abbreviations and Their Meanings (cont'd)

Abbreviation	Meaning
kPa	Kilopascals
KS	Knock Sensor
kV	Kilovolts
L	
L	Liter
L4	Four Cylinder Engine, In-line
lb	Pound
lb ft	Pound Feet (Torque)
lb in	Pound Inch (Torque)
LCD	Liquid Crystal Display
LED	Light Emitting Diode
LH	Left Hand
LT	Light
M	
MAF	Mass Airflow
Man	Manual
MAP	Manifold Absolute Pressure
MAT	Manifold Absolute Temperature
max	Maximum
M/C	Mixture Control
MDP	Manifold Differential Pressure
MFI	Multiport Fuel Injection
MIL	Malfunction Indicator Lamp
min	Minimum
mL	Milliliter
mm	Millimeter
ms	Millisecond
MST	Manifold Surface Temperature
MV	Megavolt
mV	Millivolt

Abbreviations and Their Meanings (cont'd)

Abbreviations and Their Meanings (cont'd)

Abbreviation	Meaning
N	
NC	Normally Closed
NEG	Negative
Neu	Neutral
NiMH	Nickel Metal Hydride
NLGI	National Lubricating Grease Institute
Nm	Newton-meter (Torque)
NO	Normally Open
NOx	Oxides of Nitrogen
NPTC	National Pipe Thread Coarse
NPTF	National Pipe Thread Fine
O	
O2	Oxygen
O2S	Oxygen Sensor
OC	Oxidation Converter (Catalytic)
OCS	Opportunity Charge Station
OD	Outside Diameter
ODM	Output Drive Module
OE	Original Equipment
OEM	Original Equipment Manufacturer
OHC	Overhead Camshaft
ohm	Ohm
OL	Open Loop, Out of Limits
ORC	Oxidation Reduction Converter (Catalytic)
ORN	Orange
ORVR	On-Board Refueling Vapor Recovery
OSS	Output Shaft Speed
oz	Ounce(s)
P	
PAG	Polyalkylene Glycol
PAIR	Pulsed Secondary Air
PC	Pressure Control
PCB	Printed Circuit Board
PCS	Pressure Control Solenoid
PCV	Positive Crankcase Ventilation

Abbreviation	Meaning
PIM	Power Inverter Module
PM	Permanent Magnet (Generator)
P/N	Part Number
PNK	Pink
POA	Pilot Operated Absolute (Valve)
POS	Positive, Position
POT	Potentiometer (Variable Resistor)
PPL	Purple
ppm	Parts per Million
psi	Pounds per Square Inch
psia	Pounds per Square Inch Absolute
psig	Pounds per Square Inch Gauge
pt	Pint
PTC	Positive Temperature Coefficient
Q	
qt	Quart(s)
R	
Ref	Reference
Rev	Reverse
REX	Rear Exchanger
RH	Right Hand
Rly	Relay
ROM	Read Only Memory (Permanent memory device, memory contents are retained when power is removed.)

Abbreviations and Their Meanings (cont'd)

Abbreviation	Meaning
RPM	Revolutions per Minute (Engine Speed)
RPO	Regular Production Option
RR	Right Rear
S	
s	Second(s)
SAE	Society of Automotive Engineers
SEO	Special Equipment Option
SFI	Sequential Multiport Fuel Injection
SI	System International (Modern Version of Metric System)
sol	Solenoid
SO ₂	Sulfur Dioxide
SP	Splice Pack
SPO	Service Parts Operations
sq ft, ft ²	Square Foot/Feet
sq in, in ²	Square Inch/Inches
SRI	Service Reminder Indicator
Sw	Switch
T	
TAC	Throttle Actuator Control
Tach	Tachometer
TBI	Throttle Body Fuel Injection

Abbreviations and Their Meanings (cont'd)

Abbreviation	Meaning
TDC	Top Dead Center
TEMP	Temperature
Term	Terminal
TP	Throttle Position
TV	Throttle Valve
TVV	Thermal Vacuum Valve
TWC	Three Way Converter (Catalytic)
TWC+OC	Three Way + Oxidation Converter (Catalytic)
TXV	Thermal Expansion Valve
U	
V	
V	Volt(s), Voltage
Vac	Vacuum
V dif	Voltage Difference
VDV	Vacuum Delay Valve
VIO	Violet

MAINTENANCE AND LUBRICATION

Initial Start Up Maintenance

The initial start-up checks must be made before putting the engine into service.

Please refer to *Maintenance Schedule - 1.6L Engine* on page 0-19 and perform the initial start-up operations in the sequence shown in column 1.

Routine Maintenance

Routine maintenance provides the best solution for making sure that the engine is ready when you are. The following are some routine service points:

- Keep the fuel tank filled. A full tank of fuel reduces the possibility of condensation forming in the fuel tank and moisture entering the fuel system.
- Make frequent checks of the engine oil and coolant levels.
- Repair any oil or coolant leaks immediately.
- Check battery condition and cables frequently.
- Keep the engine air filter clean.
- Monitor engine coolant temperature.
- Monitor engine oil pressure.
- Check voltmeter and charging system.

Scheduled Preventive Maintenance

Refer to the *Maintenance Schedule - 1.6L Engine* on page 0-19 to ensure that all of the maintenance items listed are checked and replaced as recommended at the hours shown.

Engine Oil Level Check

The engine oil level should be checked daily. It is recommended that the oil be checked just before the engine is started for the first time for that day. The oil level should be between the 'Add' and the 'Full' marks on the dipstick.

CAUTION: Do not operate the engine with the oil level below the bottom or 'Add' mark on the dipstick, or above the top or 'Full' mark on the dipstick.

Adding Engine Oil

It is normal to add some oil in the period of time between oil changes. The amount will vary with the severity of operation. When adding or replacing engine oil, be sure the oil meets or exceeds the recommended specification.

Engine Oil and Filter

The engine oil and filter must be changed every 200 hours or every 3 months whichever occurs first. Under normal operating conditions, you do not need to change them more often if you use oil and filters of the recommended quality.

The oil and filter should be changed more often if the engine is operating in dusty or extremely dirty areas, or during cold weather. No oil additives or break-in oil change is required.

Engine Oil Quality

To achieve proper engine performance and durability, it is important that you use only engine lubricating oils of the correct quality in your engine. Proper quality oils also provide maximum efficiency for crankcase ventilation systems, which reduces pollution.

Important: use only engine oils displaying the American Petroleum Institute (API) "Starburst" Certification Mark 'FOR GASOLINE ENGINES' on the container.

Gasoline engines that are converted for LPG or NG fuels **MUST** use oils labeled 'FOR GASOLINE ENGINES'. Do not use oils that are specifically formulated for Diesel Engines only. CC or CD classification oils, even when labeled Heavy Duty or for Natural Gas Engines, **ARE NOT ACCEPTABLE**.

Engine Oil Recommendation

Multi-viscosity oils are recommended. SAE 10W30 is recommended for your engine from 0 degrees F (-18 degrees C) or above. If ambient temperatures are consistently below 0 degrees F, SAE 5W30 oil can be used. Synthetic oils are not recommended for industrial or stationary engines.

Oil Filter

The PSI GM *Powertrain* engines use an AC Delco oil filter as original equipment. An equivalent oil filter must be used when servicing the engine (see Engine Specifications for the recommended oil filter for your engine).

The filter protects your engine from harmful, abrasive, or sludgy particles without blocking the flow of oil to vital engine parts.

To replace the filter, use a proper filter wrench to remove the filter.

Clean the filter mounting base and lightly coat the gasket surface of the new filter with engine oil. Hand tighten the filter until the gasket contacts the base, then tighten another ½ turn. Fill the engine with the correct amount of oil, run the engine and check for oil leaks at the drain plug and oil filter gasket. Tighten as necessary to stop any oil leakage noted.

Engine Air Cleaner

The engine air cleaner filters air entering the engine intake system and acts as a silencer and flame arrester when assembled to the intake system.

Air that contains dirt and grit produces an abrasive fuel mixture and can cause severe damage to the cylinder walls and piston rings. Damage to the cylinder walls and piston rings will cause high oil consumption and shorten engine life.

A restricted or dirty air cleaner will also cause a rich fuel mixture. Thus, it is extremely important that the air cleaner be serviced properly at the recommended intervals.

CAUTION: Service the air cleaner more frequently under severe dusty or dirty conditions.

Remove the primary air cleaner element from the air cleaner assembly and inspect the element for foreign material restrictions or signs of excessive wear or damage. Replace the element if necessary.

Remove all dust and foreign matter from the air cleaner housing.

Reinstall the air cleaner element. Reinstall the air cleaner cup, and securely fasten the retaining clips.

Safety Element

If your engine is equipped with an air cleaner which utilizes a safety element, ensure that the element is properly in place before installing the primary element. Change the safety element annually.

COOLING SYSTEM MAINTENANCE

Coolant Level

Check the coolant level of the radiator daily and only when the engine is cool. Generally a good time to do this is just prior to starting the engine for the first time each day.

Maintain the coolant level at ¾ to 1½ inches below the filler neck seat of the radiator when the coolant is cold. When ever coolant level checks are made inspect the condition of the radiator cap rubber seal. Make sure it is clean and free of any dirt particles which would keep it from seating on the filler neck seat. Rinse off with clean water if necessary. Also make sure that the filler neck seat is free of any dirt particles.

Caution: Never remove the radiator cap under any conditions while the engine is operating. Failure to follow these instruction could result in damage to the cooling system, engine, or cause personal injury. To avoid having scalding hot coolant or steam blow out of the radiator, use extreme caution when removing the radiator cap from a hot radiator. If possible, wait until the engine has cooled, then wrap a thick cloth around the radiator cap and turn slowly to the first stop. Step back while the pressure is released from the cooling system. When all the pressure has been released, press down on the cap and remove it slowly.

Notice: DO NOT add coolant to any engine that has become overheated until the engine cools. Adding coolant to an extremely hot engine can result in a cracked block or cylinder head.

Coolant Level - Continued

Use only a permanent-type coolant when refilling or flushing the coolant system.

Recommended ethylene glycol mix 52/48 is normal up to a maximum of 60% glycol, 40% water.

Refer to the mixture chart on the container for additional antifreeze protection information. DO NOT use alcohol or methanol antifreeze, or mix them with the specified coolant.

Plain water may be used in an emergency (except in freezing temperatures), but replace it with the specified coolant as quickly as possible to avoid damage to the system.

Radiator

Inspect the exterior of the radiator for obstructions. Remove all bugs, dirt or foreign material with a soft brush or cloth. Use care to avoid damaging the core fins. If available, use low pressure compressed air or a stream of water in the opposite direction of the normal air flow.

Radiator Hoses

Check all hoses and connections for leaks. If any of the hoses are cracked, frayed, or feel spongy, they must be replaced.

Fan Belts

The water pump is usually belt driven. The same belt may also drive the fan and/or the alternator. The drive belts should be properly adjusted at all times. A loose belt can cause improper alternator, fan and water pump operation, in addition to overheating.

Serpentine Belt

Some GM *Powertrain* engines utilize serpentine belts on the front of the engine. This type of belt system incorporates a belt tensioning device which keeps the belt at the proper tension.

This belt should be checked routinely for cracks or 'checking' on the groove side of the belt. If cracks or 'checking' are apparent the belt must be changed.

V-Type Belt

V-Type belts are generally tensioned by adjusting the alternator position, or through a mechanical belt tensioner. The belt is generally correctly tensioned when there is an ½ inch of depression on the belt between the water pump and the crankshaft pulley.

FUEL DELIVERY SYSTEM MAINTENANCE

Fuel Filter Replacement

Carbureted Engines

On carbureted engines, an in-line fuel filter is incorporated into the fuel supply line. It is recommended that this filter be changed every 250 hours or every 6 months which ever occurs first.

TBI Engines

On PSI Fuel Injection or Fuel Injection/Dual Fuel two fuel filters are used in the gasoline fuel supply line to the engine TBI unit. A coarse fuel filter is located in the supply line between the fuel tank and the electric fuel pump. This filter protects the fuel pump from debris in the fuel tank. This filter must be changed every 200 hours or every 6 months which ever occurs first.

A primary fuel filter is located between the fuel pump and the TBI unit on the engine. This filter protects the injectors from microscopic particles in the fuel which can cause plugging of the injectors. This filter **MUST** be changed every 500 hours or annually which ever occurs first.

Zenith Z.E.E.M.S. TBI Fuel Injection

Zenith Z.E.E.M.S. TBI Fuel Injection requires an in-line fuel filter in the fuel supply line from the fuel tank to the TBI unit, ahead of the electric fuel supply pump. This filter must be changed every 400 hours or every 6 months which ever occurs first.

On engines equipped to run on LPG, the in-line fuel filter must be replaced every 800 hours.

Fuel Delivery System Maintenance - Continued

CAUTION: Failure to change the fuel system filters as recommended can result in premature failure of the TBI fuel system components.

NOTE: Some original equipment manufacturers install their own fuel systems. Please refer to the manufacturers manual if the gasoline fuel system is different than described here.

WARNING: Use extreme care when changing the fuel filters on gasoline engines. Gasoline is highly flammable and should not be exposed to open flame, sparks, or hot engine components. Allow the engine to cool to ambient temperatures prior to changing fuel filters.

Ignition Systems

Types of Ignition Systems

Three types of ignition systems are used on PSI GM *Powertrain* engines. Solid state electronic distributor, solid state electronic distributor with ECU (Electronic Control Unit) and distributorless electronic ignition (DIS) with ECU.

Please refer to the *Section 3, Engine Electrical*, for a description of the ignition system used on your particular engine.

Ignition Timing

Proper adjustment of the ignition timing must be obtained to provide the optimum engine power output and economy. However, since the 1.6L engine uses a distributorless ignition system which is controlled entirely by the electronic control unit, or ECU, the ignition timing cannot be adjusted by the user. Refer to *Section 3, Engine Electrical*, for a description of the distributorless ignition system.

Spark Plugs

Spark plugs should be replaced at the recommended intervals described in the Maintenance Schedule. Use only the recommended spark plug or an equivalent as described in *Section 3, Engine Electrical*.

Spark plug gap, should be adjusted as recommended in *Section 3, Engine Electrical*.

When removing spark plugs, always note which cylinder each plug came out of. Look at the porcelain around the center electrode of each plug. You can detect many engine problems from the color and type of deposits that have built up on the white porcelain. For example, if the deposits are a glossy brown, that cylinder is burning excess oil. If the deposits are a very dark gray or sooty black color, your engine is running rich, and you are burning excess fuel. The optimum color of the deposits on the porcelain is light tan or light brown. This shows optimum fuel mixture and proper engine running conditions. If the deposits are almost white, the engine may be running excessively lean. Lean running is very detrimental to your engine life, and should be corrected immediately.

If one or more cylinders are burning oil, the smoke from the engine will be a blue-gray color. Most common causes are piston rings (worn out or not broken in) and valve stem seals (cut, nicked, or worn out). If the engine is running rich the exhaust smoke will be a sooty black color and it will smell like gasoline (on gasoline engines).

MAINTENANCE SCHEDULE - 1.6L ENGINE

Initial Start-Up Sequence Checks	Operation	Daily	Weekly	Every 50 hrs	Every 100 hrs	Every 200 hrs	Every 400 hrs	Every 800 hrs	As Req.
1	Check Engine Oil Level	x							
2	Check Coolant Level	x							
3	Check for Fluid Leaks	x							
4	Governor, Mechanical (Check oil level)(2)		x						
	Change Engine Oil & Filter (1)					x			
5	Battery, Check Charge & Fluid Level		x						
	Inspect & Clean Radiator Exterior		x						
	Clean Battery Cables								x
6	Check Belts and Belt Tension				x				
	Lubricate Throttle, Governor & Choke Linkage (Carbureted Engines Only)				x				
	Check & Adjust Idle Speed (Carbureted Engines Only)								x
	Inspect and Clean Air Cleaner Element		x						
	Replace Primary Air Cleaner Element (1)						x		
	Replace Safety Air Cleaner Element								x
	Check Coolant Protection & Tighten Hose Clamps						x		
	Replace Engine Coolant (3)							x	
	Replace Gasoline Fuel Filter (4)						x		
	Replace LPG Filter – Zenith EFI (4)							x	
	Replace PCV Valve (If Equipped)							x	
	Check PCV Hoses, Tubes, and Fittings							x	
	Replace Spark Plugs (3)							x	
	Distributor Cap & Rotor (5)							x	
	Secondary Ignition Wires							x	
	Adjust Throttle & Governor (3)								x
7	Check All Engine Bolts & Nuts for Tightness								x

- (1) More frequent intervals may be required in dusty or dirty operating conditions.
- (2) Mechanical governor (belt driven).
- (3) To be performed at specified interval or annually, whichever occurs first.
- (4) More frequent intervals may be required with dirt in the fuel system.
- (5) Does not apply to engines with DIS ignition.

Approximate Fluid Capacities

Application	Specification	
	Metric	English
Engine Cooling System		
1.6L Without Radiator	3.3 L	3.5 qts.
1.6L With Radiator	9.5 L	10.0 qts.
Engine Crankcase		
1.6L With Filter	3.5 L	3.7 qts.
1.6L Without Filter	3.2 L	3.4 qts.

FILTER CHART - 1.6L ENGINE

Engine	1.6L
Oil Filter	25010792
Fuel Filter (Carbureted)	N/A
Fuel Filter (PSI TBI Coarse)	N/A
Fuel Filter (PSI TBI Fine)	N/A
Fuel Filter Zenith Z.E.E.M.S	Gasoline C282-224 LPG C282-5
Air Filter Primary (PSI Power Unit)	N/A
Air Filter Safety (PSI Power Unit)	N/A

Section 1

Engine Mechanical

Fastener Notice	1-2	Drive Disc, Remove and Install	1-54
Engine Mechanical - 1.6L	1-3	Flywheel, Remove and Install	1-54
Specifications	1-3	Seal Ring - Rear Crankshaft, Replace	1-55
Fastener Tightening Specifications	1-4	Engine Vent Flange or Gasket, Remove and Install ..	1-56
Sealers, Adhesives and Lubricants	1-6	Piston with Con-rod, Remove and Install	1-57
Engine Mechanical Specifications	1-7	Piston Rings, Remove and Install	1-61
Engine Identification Code/Engine Number	1-7	Con-rod Bearing, Replace	1-63
Engine Management	1-7	Con-rod Bearing Clearance, Check (Determine	
Cylinder Head	1-8	Bearing Clearance with 50 Plastigage)	1-64
Crank Drive, Cylinder Block	1-10	Con-rod Bearing Clearance, Check (Determine Bearing	
Diagnostic Information and Procedures	1-17	Clearance with Micrometer and Inside	
Tension Check, Ribbed V-belt	1-17	Micrometer)	1-65
Engine Compression Test	1-17	Piston, Replace	1-66
Engine Loss of Compression Test	1-18	Crankshaft, Remove and Install	1-68
Oil Pressure Check	1-19	Crankshaft, Check	1-70
Timing Check	1-20	Crankshaft End Clearance, Check	1-70
Timing Adjustment	1-20	Crankshaft Out-of-round, Check	1-70
Toothed Belt Tension Check	1-23	Crankshaft Bearing Play, Check (Determine Bearing	
Toothed Belt Tension Adjust	1-24	Play with Plastigage)	1-70
Repair Instructions	1-25	Crankshaft Bearing Clearance, Check (Determine	
Engine Timing Side	1-25	Crankshaft Bearing Clearance Using External	
Ribbed V-belt, Remove and Install	1-25	Micrometer and Inside Micrometer)	1-71
Toothed Belt Cover, Upper Part, Remove and Install	1-26	Cylinder Block, Check for Plane Surface	1-72
Toothed Belt Cover, Lower Part, Remove and Install	1-27	Oil Circuit	1-73
Toothed Belt, Remove and Install	1-28	Oil Filter, Replace	1-73
Toothed Belt Tension Roller, Remove and Install	1-29	Bypass Valve, Replace	1-73
Seal Ring in Front Camshaft Housing, Replace	1-30	Front Seal Ring - Crankshaft, Replace	1-73
Rear Toothed Belt Cover, Remove and Install	1-32	Oil Pan, Remove and Install	1-76
Cylinder Head	1-34	Oil Pump, Remove and Install	1-77
Seal Ring in Rear Camshaft Housing, Replace	1-34	Oil Pump, Check	1-79
Exhaust Manifold, Remove and Install	1-35	Safety Valve, Remove and Install	1-81
Intake Manifold, Remove and Install - Port Fuel Injected		Oil Intake Pipe, Remove and Install	1-81
Models	1-36	Oil Baffle Plate, Remove and Install	1-82
Intake Manifold, Remove and Install - Throttle Body Fuel		Oil Pressure Switch, Remove and Install	1-82
Injected Models	1-38	Oil Dipstick Tube, Remove and Install	1-83
Heat Shields, Remove and Install	1-40	Crankshaft Position Sensor, Remove and Install	1-83
Camshaft and Cam Follower, Remove and Install		Reference Gap Between Crankshaft Position Sensor	
(Cylinder head Installed)	1-40	and Increment Disc, Check	1-83
Hydraulic Valve Lifter, Replace (Cylinder Head		Coolant Thermostat, Remove and Install	1-84
Installed)	1-43	Coolant Pump, Remove and Install	1-84
Camshaft, Remove and Install (Cylinder Head		Fuel Pressure Check	1-84
Removed)	1-44	Coolant Temperature Sensor, Remove and Install	1-85
Camshaft Housing, Replace	1-44	Starter	1-86
Camshaft Housing, Check for Plane Surface	1-47	Starter, Remove and Install	1-86
Cylinder Head, Remove and Install	1-47	Alternator	1-86
Cylinder Head, Check for Plane Surface	1-53	Alternator, Remove and Install	1-86
Crank Drive, Cylinder Block	1-54	Special Tools and Equipment	1-88

Fastener Notice

NOTICE: Always use the correct fastener in the proper location. When you replace a fastener, use **ONLY** the exact part number of that application.

PSI will call out those fasteners that require a replacement after removal. PSI will also call out the fasteners that require thread lockers or thread sealant.

UNLESS OTHERWISE SPECIFIED, Do Not use supplemental coatings (paints, greases or other corrosion inhibitors) on threaded fasteners or fastener joint interfaces. Generally, such coating adversely affect the fastener torque and the joint clamping force, and may damage the fastener.

When you install fasteners, use the correct tightening sequence and specifications.

Following these instructions can help you avoid damage to parts and systems.

Engine Mechanical - 1.6L

Specifications

Engine 1.6L Industrial	Specification	
	Metric	English
Number of cylinders/layout	4 In Line	
Number of valves	8	
Capacity	1598 cm ³	97.5 cu in
Bore Diameter	79 mm	3.11 in
Stroke	81.5 mm	3.2 in
Power Output	62 KW @ 5400 rpm	46.2 Hp @ 5400 rpm
Torque	138 N•m @ 2600 rpm	101.8 lb ft @ 2600 rpm
Compression	9.4:1	

Fastener Tightening Specifications

Application	Specification	
	Metric	English
Starter to cylinder block	40 N@m	13 lb ft
Drive disc to crankshaft	25 N@m	18 lb ft
Exhaust manifold to cylinder head	55 N@m + 30° + 15° ¹⁾	106 lb in
Camshaft sensor fastening bolt to camshaft housing	18 N@m	13 lb ft
DIS Ignition Module to camshaft housing carrier	18 N@m	13 lb ft
Throttle valve injection housing to intake manifold	10 N@m	89 lb in
Upper part of throttle valve injection housing to throttle valve injection housing	10 N@m	89 lb in
Throttle body to intake manifold	2 N@m	18 lb in
Pressure plate to camshaft housing	8.5 N@m	75 lb in
Intake manifold to cylinder head	22 N@m	16 lb ft
Alternator to alternator support	1.5 N@m	13 lb in
Alternator to alternator shackle	1.5 N@m	13 lb in
Alternator support to cylinder block	25 N@m	18 lb ft
Crankshaft pulse pickup bracket to oil pump	4.5 N@m	40 lb in
Wiring harness bracket to intake manifold	2 N@m	18 lb in
Rear toothed belt cover to camshaft housing	16 N@m	12 lb ft
Rear toothed belt cover to oil pump and camshaft housing	2.8 N@m	25 lb in
Heat shield to exhaust manifold	50 N@m	37 lb ft
Heat shield sleeves (sparkplugs) to cylinder head	9 N@m	80 lb in
Crankshaft pulse pickup to bracket	35 N@m	26 lb ft
Increment disc to toothed belt drive gear	8.5 N@m	75 lb in
Wiring trough to cylinder head	8 N@m	71 lb in
Knock sensor to cylinder head	20 N@m	15 lb ft
Application	Specification	
	Metric	English
Fuel supply and return line to throttle valve guards	15 N@m	11 lb ft
Coolant pump to cylinder block	8 N@m	71 lb in
Coolant pipe to cylinder block	20 N@m	15 lb ft
Crankshaft bearing cap to cylinder block	50 N@m + 45° + 15° ¹⁾	37 lb ft
Alternator shackle to intake manifold	20 N@m	15 lb ft
Fan housing to radiator	5 N@m	44 lb in
Camshaft housing cover to camshaft housing	8 N@m	71 lb in
Camshaft sprocket to camshaft	45 N@m	33 lb ft
Oil drain bolt to oil pan	55 N@m	41 lb ft
Oil pressure switch to oil pump	30 N@m	22 lb ft
Oil filter to oil pump	15 N@m	11 lb ft
Oil pump to cylinder block	10 N@m	89 lb in
Oil pump cover to oil pump	6 N@m	53 lb in
Oil intake pipe to oil pump	8 N@m ¹⁾	71 lb in
Oil intake pipe to cylinder block	8 N@m	71 lb in
Oil baffle plate to oil pan	8 N@m	71 lb in

Fastener Tightening Specifications (Continued)

Application	Specification	
	Metric	English
Fuel supply and return line to throttle valve guards	15 N@m	11 lb ft
Coolant pump to cylinder block	8 N@m	71 lb in
Coolant pipe to cylinder block	20 N@m	15 lb ft
Crankshaft bearing cap to cylinder block	50 N@m + 45° + 15° ¹⁾	37 lb ft
Alternator shackle to intake manifold	20 N@m	15 lb ft
Fan housing to radiator	5 N@m	44 lb in
Camshaft housing cover to camshaft housing	8 N@m	71 lb in
Camshaft sprocket to camshaft	45 N@m	33 lb ft
Oil drain bolt to oil pan	55 N@m	41 lb ft
Oil pressure switch to oil pump	30 N@m	22 lb ft
Oil filter to oil pump	15 N@m	11 lb ft
Oil pump to cylinder block	10 N@m	89 lb in
Oil pump cover to oil pump	6 N@m	53 lb in
Oil intake pipe to oil pump	8 N@m ¹⁾	71 lb in
Oil intake pipe to cylinder block	8 N@m	71 lb in
Oil baffle plate to oil pan	8 N@m	71 lb in
Oil pan to oil pump	10 N@m ¹⁾	89 lb in
Oil pan to cylinder block	10 N@m ¹⁾	89 lb in
Con-rod bearing cap to con-rod	25 N@m + 30° ³⁾	18 lb ft
Flywheel to crankshaft	35 N@m + 30° + 15° ¹⁾	26 lb ft
Coolant temperature sensor to intake manifold	20 N@m	15 lb ft
Support to alternator and intake manifold	20 N@m	15 lb ft
Thermostat housing to cylinder head	10 N@m	89 lb in
Carrier plate (DIS ignition module) to camshaft housing	12 N@m	106 lb in
Closure bolt, safety valve to oil pump	50 N@m	37 lb ft
Front exhaust pipe to exhaust manifold (hex bolts)	35 N@m ²⁾	26 lb ft
Front exhaust pipe to exhaust manifold (hex nuts)	45 N@m ³⁾	33 lb ft
Toothed belt cover – upper part to rear toothed belt cover	4 N@m	35 lb in
Toothed belt cover – lower part to rear toothed belt cover	4 N@m	35 lb in
Toothed belt tension roller to oil pump	20 N@m	37 lb ft
Spark plug to cylinder head	25 N@m	18 lb ft
Cylinder head and camshaft housing to cylinder block	25 N@m + 85° + 85° ²⁾	18 lb ft

- 1) Use new bolts.
- 2) Insert bolts with mounting paste (white).
- 3) Use new nut(s).

Sealants, Adhesives, and Lubricants

Engine	1.6 L Z 16 LE		
Crankshaft Dimensions	Main Bearing Journals 1 -5		Color Code
Standard size	54.980 – 54.997 mm	2.1646 – 2.1652 in	brown
	54.980 – 54.997 mm	2.1646 – 2.1652 in	green
Undersize (0.25)	54.730 – 54.747 mm	2.1547 – 2.1554 in	brown/blue
	54.730 – 54.747 mm	2.1547 – 2.1554 in	green/blue
Undersize (0.50)	54.482 – 54.495 mm	2.1450 – 2.1455 in	brown/white
	54.482 – 54.495 mm	2.1450 – 2.1455 in	green/white
	Con-rod bearing journal		
Standard size	42.971 – 42.987 mm	1.6918 – 1.6924 in	-
Undersize (0.25)	42.721 – 42.737 mm	1.6819 – 1.6826 in	blue
Undersize (0.50)	42.471 – 42.487 mm	1.6721 – 1.6727 in	white
	Wide main bearing journals		
Standard size	26.000 – 26.052 mm	1.024 – 1.026 in	-
Undersize (0.20)	26.200 – 26.252 mm	1.031 – 1.034 in	-
Undersize (0.40)	26.400 – 26.452 mm	1.039 – 1.041 in	-

Engine Mechanical Specifications

Engine Identification Code / Engine Number

The engine identification code is embossed on the flattened area (arrow) of the cylinder block on the upper rear side.

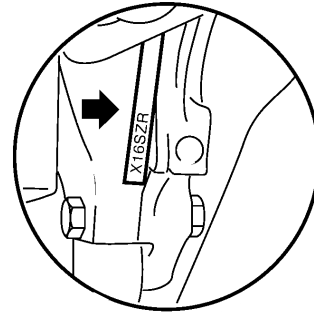

Engine Management

Engine Displacement	1.6L
Engine Designation	Multec-S Z 16 SE
Ignition Sequence	1-3-4-2
Spark Plugs	FLR 8 LDCU

Cylinder Head

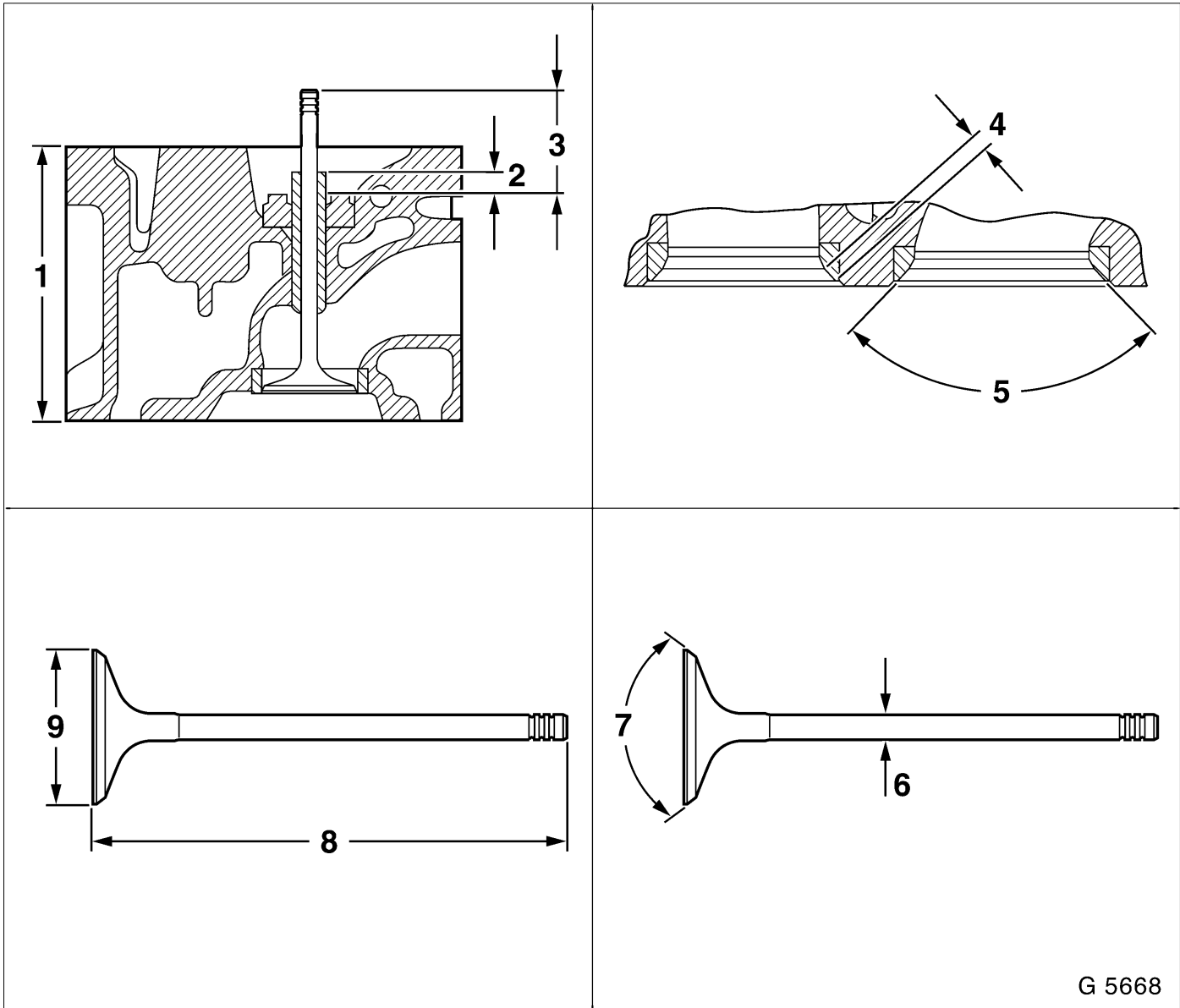

Cylinder Head

Illustration

- 1 Cylinder head height
- 2 Installation height of valve guide
- 3 Installation height of valve
- 4 Valve seat width in cylinder head
- 5 Valve seat angle in cylinder head
- 6 Valve stem diameter
- 7 Valve seat angle at valve
- 8 Valve length
- 9 Valve head – diameter

Cylinder Head (Continued)

Cylinder Head – 1.6L Engine	Specification	
	Metric	English
Cylinder head height ¹⁾	95.9 – 96.1 mm	3.776 – 3.783 in
Intake valve seat width in cylinder head	1.3 – 1.5 mm	0.051 – 0.059 in
Exhaust valve seat width in cylinder head	1.6 – 1.8 mm	0.063 – 0.071 in
Valve seat angle in cylinder head	90°	90°
Standard size inside valve guide diameter	7.030 – 7.050 mm	0.277 – 0.278 in
Oversize (0.075) inside valve guide diameter	7.105 – 7.125 mm	0.280 – 0.281 in
Oversize (0.150) inside valve guide diameter	7.180 – 7.200 mm	0.283 – 0.283 in
Length of intake valve guide	45.5 mm	1.79 in
Length of exhaust valve guide	45.5 mm	1.79 in
Installation height of valve guide	80.85 – 81.25 mm	3.18 – 3.20 in
Installation height of valves	13.75 – 14.35 mm	0.541 – 0.565 in
Valve length, standard size intake valve (GM)	101.65 – 101.95 mm	4.001 – 4.014 in
Valve length, standard size exhaust valve (GM)	101.15 – 101.85 mm	3.982 – 4.010 in
Valve length, over size (0.075) intake valve (GM K1)	101.25 – 101.55 mm	3.986 – 3.998 in
Valve length, over size (0.075) exhaust valve (GM K1)	100.75 – 101.45 mm	3.967 – 3.994 in
Valve length, over size (0.150) intake valve (GM K2)	101.25 – 101.55 mm	3.986 – 3.998 in
Valve length, over size (0.150) exhaust valve (GM K2)	100.75 – 101.45 mm	3.967 – 3.994 in
Standard size intake valve length (GM)	6.998 – 7.012 mm	0.275 – 0.276 in
Standard size exhaust valve length (GM)	6.978 – 6.992 mm	0.275 – 0.275 in
Over size (0.075) intake valve stem length (GM K1)	7.073 – 7.087 mm	0.278 – 0.279 in
Over size (0.075) exhaust valve stem length (GM K1)	7.053 – 7.067 mm	0.278 – 0.278 in
Over size (0.150) intake valve stem length (GM K2)	7.148 – 7.162 mm	0.281 – 0.282 in
Over size (0.150) exhaust valve stem length (GM K2)	7.128 – 7.142 mm	0.281 – 0.281 in
Intake valve stem play	0.018 – 0.052 mm	.0007 - .0020 in
Exhaust valve stem play	0.038 – 0.072 mm	.0015 - .0028 in
Perm. runout of the valve stem	0.03 mm	.0012 in
Ø Valve head, intake valve	38.0 mm	1.5 in
Ø Valve head, exhaust valve	31.0 mm	1.22 in
Valve seat angle at valve head	92°	92°
Camshaft lift, intake valve	9.08 mm	.357 in
Camshaft lift, exhaust valve	9.99 mm	.393 in

Crank Drive, Cylinder Block

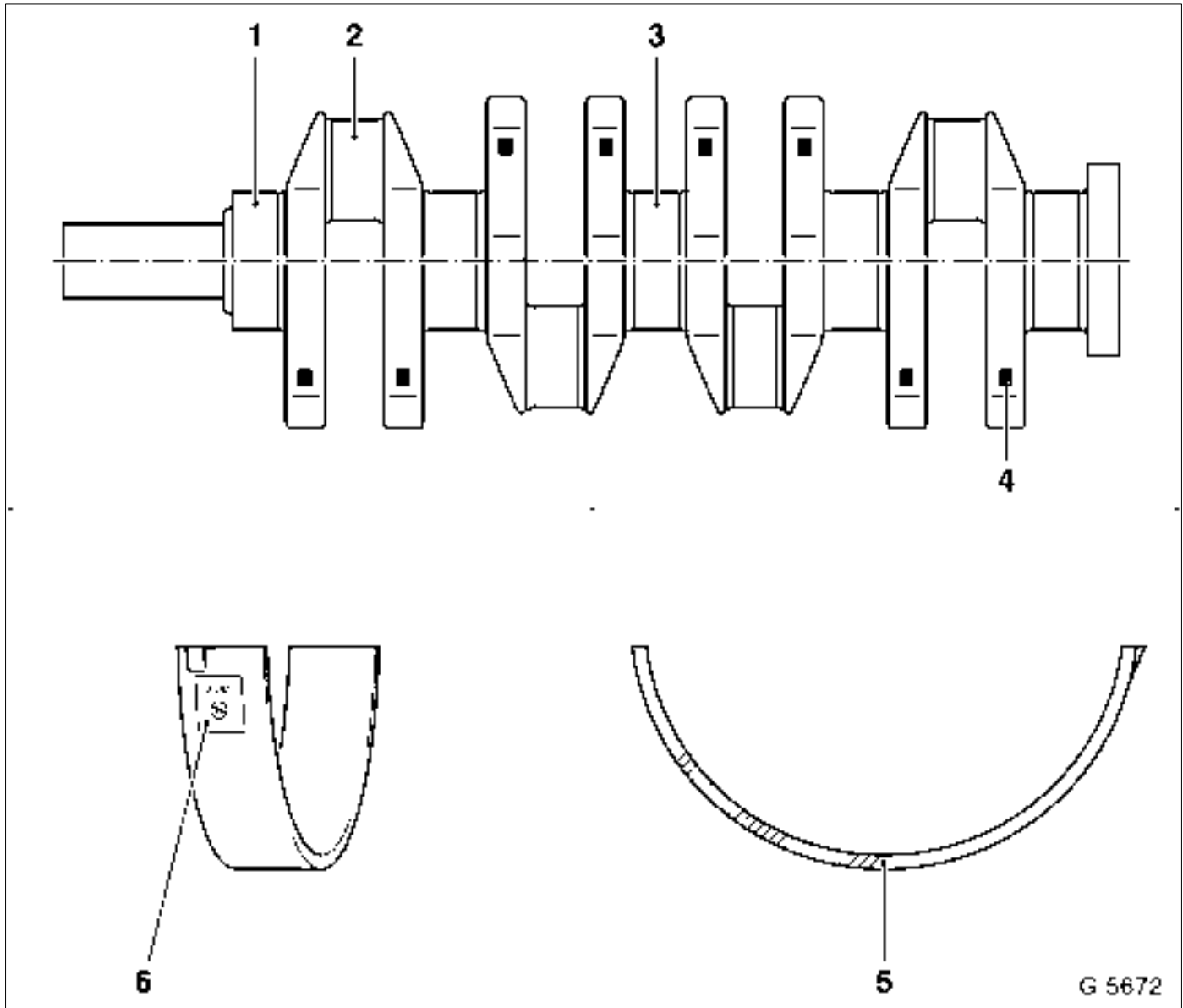

Crank Drive, Cylinder Block

Illustration

- 1 Main Bearing Journals
- 2 Con-rod bearing journal
- 3 Main Bearing Journals (Guide Bearing)
- 4 Crankshaft color code
- 5 Bearing shell color code
- 6 Bearing shell identification

Crank Drive, Cylinder Block (Continued)

Engine	1.6 L Z 16 LE		
Crankshaft Dimensions	Main Bearing Journals 1 -5		Color Code
Standard size	54.980 – 54.997 mm	2.1646 – 2.1652 in	brown
	54.980 – 54.997 mm	2.1646 – 2.1652 in	green
Undersize (0.25)	54.730 – 54.747 mm	2.1547 – 2.1554 in	brown/blue
	54.730 – 54.747 mm	2.1547 – 2.1554 in	green/blue
Undersize (0.50)	54.482 – 54.495 mm	2.1450 – 2.1455 in	brown/white
	54.482 – 54.495 mm	2.1450 – 2.1455 in	green/white
	Con-rod bearing journal		
Standard size	42.971 – 42.987 mm	1.6918 – 1.6924 in	-
Undersize (0.25)	42.721 – 42.737 mm	1.6819 – 1.6826 in	blue
Undersize (0.50)	42.471 – 42.487 mm	1.6721 – 1.6727 in	white
	Wide main bearing journals		
Standard size	26.000 – 26.052 mm	1.024 – 1.026 in	-
Undersize (0.20)	26.200 – 26.252 mm	1.031 – 1.034 in	-
Undersize (0.40)	26.400 – 26.452 mm	1.039 – 1.041 in	-

Crank Drive, Cylinder Block (Continued)

Engine	1.6 L Z 16 SE			
Crankshaft bearing 1,2,4,5	Lower crankshaft bearing shell			
	Color code	Thickness (Metric)	Thickness (English)	Code GM 400
Standard Size	brown	1.989 – 1.995 mm	0.0783 – 0.0785 in	221 N
	green	1.995 – 2.001 mm	0.0785 – 0.0788 in	201N
Undersize (0.25)	brown/blue	2.114 – 2.120 mm	0.0832 – 0.0835 in	222 A
	green/blue	2.120 – 2.126 mm	0.0835 – 0.0837 in	202 A
Undersize (0.50)	brown/white	2.239 – 2.245 mm	0.0881 – 0.0884 in	223 B
	green/white	2.245 – 2.251 mm	0.0884 – 0.0886 in	203 B
	Upper crankshaft bearing shell			
Standard Size	brown	1.989 – 1.995 mm	0.0783 – 0.0785 in	221 N
	green	1.995 – 2.001 mm	0.0785 – 0.0788 in	201N
Undersize (0.25)	brown/blue	2.114 – 2.120 mm	0.0832 – 0.0835 in	222 A
	green/blue	2.120 – 2.126 mm	0.0835 – 0.0837 in	202 A
Undersize (0.50)	brown/white	2.239 – 2.245 mm	0.0881 – 0.0884 in	223 B
	green/white	2.245 – 2.251 mm	0.0884 – 0.0886 in	203 B
Perm. bearing clearance	-	0.015 – 0.041 mm	.00059 - 0.0016 in	-
Perm. end clearance	-	0.100 – 0.202 mm	0.004 – 0.008 in	-
Perm. out of round	-	0.03 mm	0.0012 in	-
Crankshaft bearing 3	Lower crankshaft bearing shell			
	Color code	Thickness (Metric)	Thickness (English)	Code GM 400
Standard size	brown	1.989 – 1.995 mm	0.0783 – 0.0785 in	225 N
	green	1.995 – 2.001 mm	0.0785 – 0.0788 in	205N
Undersize (0.25)	brown/blue	2.114 – 2.120 mm	0.0832 – 0.0835 in	226 A
	green/blue	2.120 – 2.126 mm	0.0835 – 0.0837 in	206 A
Undersize (0.50)	brown/white	2.239 – 2.245 mm	0.0881 – 0.0884 in	227 B
	green/white	2.245 – 2.251 mm	0.0884 – 0.0886 in	207 B
	Upper crankshaft bearing shell			
Standard Size	brown	1.989 – 1.995 mm	0.0783 – 0.0785 in	225 N
	green	1.995 – 2.001 mm	0.0785 – 0.0788 in	205 N
Undersize (0.25)	brown/blue	2.114 – 2.120 mm	0.0832 – 0.0835 in	226 A
	green/blue	2.120 – 2.126 mm	0.0835 – 0.0837 in	206 A
Undersize (0.50)	brown/white	2.239 – 2.245 mm	0.0881 – 0.0884 in	227 B
	green/white	2.245 – 2.251 mm	0.0884 – 0.0886 in	207 B

Crank Drive, Cylinder Block (Continued)

Engine	1.6 L Z 16 SE			
	Color code	Width (Metric)	Width (English)	Code GM 400
3 wide main bearing journals (guide bearing)				
Standard Size	green-brown	25.850 – 25.900 mm	1.0177 – 1.0197 in	-
Undersize (0.25)	brown/blue	26.050 – 26.100 mm	1.0256 – 1.0276 in	-
	green/blue			
Undersize (0.50)	brown/white	26.250 – 26.300 mm	1.0335 – 1.0354 in	-
	green/white			

Crank Drive, Cylinder Block (Continued)

Engine	1.6 L Z 16 SE			
	Lower con-rod bearing shell			
Con-rod bearing	Color code	Thickness (Metric)	Thickness (English)	Code GM 400
Standard Size	-	1.485 – 1.497 mm	0.0585 – 0.0589 in	264 N
Undersize (0.25)	blue	1.610 – 1.622 mm	0.0634 – 0.0639 in	265 A
Undersize (0.50)	white	1.735 – 1.747 mm	0.0683 – 0.0688 in	266 B
	Upper con-rod bearing shell			
Standard Size	-	1.485 – 1.497 mm	0.0585 – 0.0589 in	264 N
Undersize (0.25)	blue	1.610 – 1.622 mm	0.0634 – 0.0639 in	265 A
Undersize (0.50)	white	1.735 – 1.747 mm	0.0683 – 0.0688 in	266 B
Perm. con-rod play	-	0.019 – 0.071 mm	.00075 - .00280 in	-

Crank Drive, Cylinder Block (Continued)

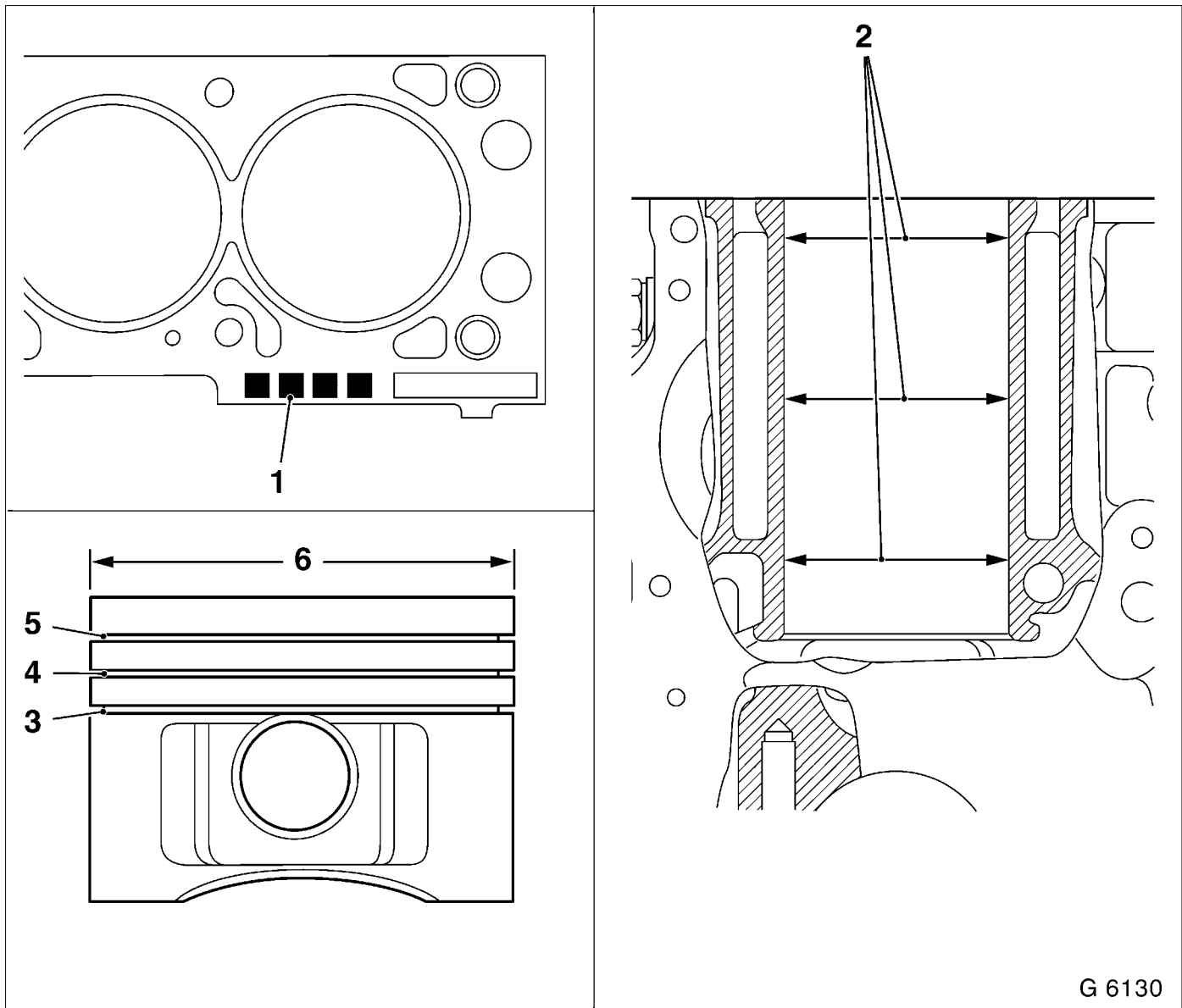

Crank Drive, Cylinder Block (Continued)

Illustration

- 1 Index – identification of cylinder bore
- 2 Cylinder bore
- 3 Double bevelled ring with spiral-type expander
- 4 Tapered compression ring or double trapezoidal ring
- 5 Rectangular compression ring
- 6 Piston diameter

Illustration

Crank Drive, Cylinder Block (Continued)

Engine	1.6 L Z 16 SE	
Cylinderbore	Width (Metric)	Width (English)
Standard size		
Index 8	78.975 - 78.985 mm	3.1093 – 3.1096 in
Index 99	78.985 - 78.995 mm	3.1096 – 3.1100 in
Index 00	78.995 - 79.005 mm	3.1100 – 3.1104 in
Index 01	79.005 - 79.015 mm	3.1104 – 3.1108 in
Index 02	79.015 - 79.025 mm	3.1108 – 3.1112 in
Oversize ¹⁾		
Index 7 + 0.5	79.465 - 79.475 mm	3.1285 – 3.1289 in
Piston	Width (Metric)	Width (English)
Standard size		
Index 8	78.955 - 78.965 mm	3.1085 – 3.1089 in
Index 99	78.965 - 78.975 mm	3.1089 – 3.1093 in
Index 00	78.975 - 78.985 mm	3.1093 – 3.1096 in
Index 01	78.985 - 78.995 mm	3.1096 – 3.1100 in
Index 02	78.995 - 79.005 mm	3.1100 – 3.1104 in
Oversize ¹⁾		
Index 7 + 0.5	79.445 - 79.455 mm	3.1278 – 3.1281 in
Piston clearance	0.01 – 0.03 mm	.00039 - .00118 in
Piston projection	0.4 mm	.01575 in

- 1) After reboring, the old index must be invalidated and the new oversizing index must be embossed.

Crank Drive, Cylinder Block (Continued)

Engine Piston Rings	1.6 L Z 16 SE	
	Specification (Metric)	Specification (English)
Rectangular compression ring		
Height	1.20 mm	0.0472 in
Gap	0.30 – 0.50 mm	0.0118 – 0.0197 in
Vertical play	0.02 – 0.04 mm	0.00079 - 0.00157 in
Tapered compression ring		
Height	1.50 mm	0.059 in
Gap	0.30 - 0.50 mm	0.0118 – 0.0197 in
Vertical play	0.04 – 0.06 mm	0.00157 – 0.00236 in
Oil scraper ring		
Height	3.00	0.1181 in
Gap	0.40 – 1.40	0.0157 – 0.0551 in
Vertical play	0.01 – 0.03	0.00039 – 0.00118 in
Ring gap distribution ¹⁾	120°	120°

- 1) Arrange gap of upper coil scraper ring 25 to 50 mm (1 - 2 in.) offset to the left and gap of the lower ring 25 to 50 mm (1 - 2 in.) offset to the right relative to the gap of the lower intermediate ring.

Engine Pistonpin	1.6 L Z 16 SE	
	Width (Metric)	Width (English)
Length	5.50 mm	0.2165 in
Diameter	17.997 – 18.000 mm	0.7085 – 0.7087 in
Bearing	78.985 - 78.995 mm	3.1096 – 3.1100 in
Clearance		
in piston	0.009 – 0.012 mm	.00035 – .00047 in
in con-rod	0.0 mm	0.0 in

Diagnostic Information and Procedures

Ribbed V-belt Tension, Check

Drive belts must grip the entire contact area of the pulley. When drive belts are too loose, the belts can slip, tear, burn, or grab and snap. More belts fail from being too loose than too tight.

Belts that are too tight can damage the engine by causing side loading of the crankshaft, crankshaft bearings, and accessories or accessory bearings. Too much belt tension will also stretch and weaken the belt.

When the drive belts are worn, they should be replaced. Tightening worn drive belts will not prevent slipping, and can also cause damage to the engine.

Do not use belt dressings to extend belt life. Most dressings contain chemicals which soften the belt.

Tools Required:

- 6" Steel Rule

1. Inspect the drive belt for:
 - Cracks
 - Glazing
 - Tears or cuts
 - Excessive wear
2. Measure the amount of play in the belt. The fan belt should measure approximately 1/2 inch (13 mm) deflection.

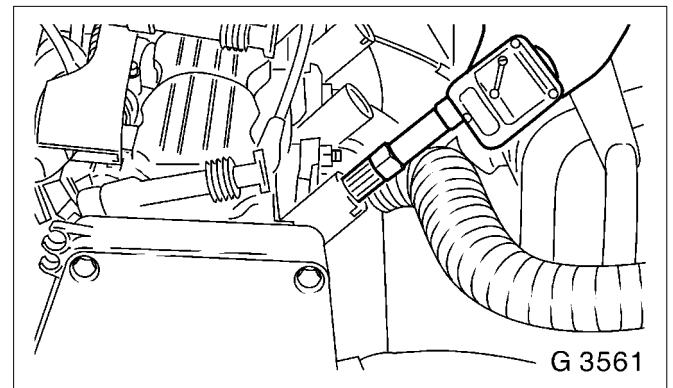
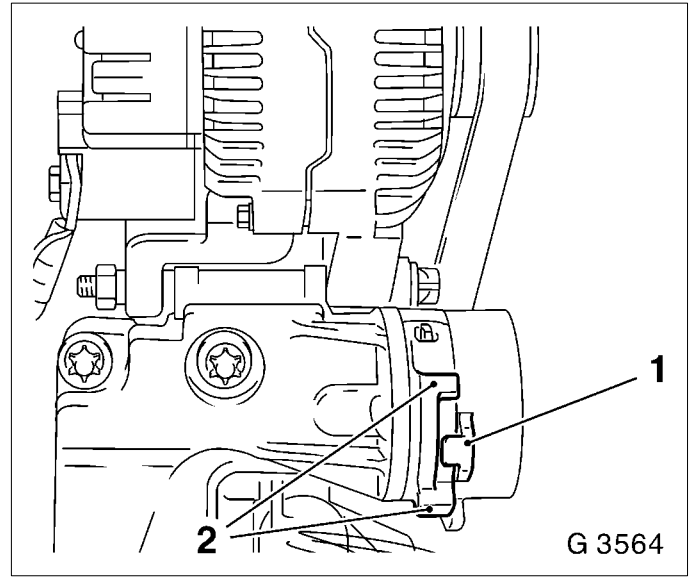

Engine Compression Test

Removal Procedure

1. With engine at operating temperature (oil temperature 80 °C), detach spark plug connectors and remove spark plugs with KM-194-E.
2. Detach wiring harness plug (1) from DIS ignition module.
3. Open relay holder cover and pull fuel pump relay (2) out of base.

Inspect

1. Use compression recorder with rubber cone and a measuring range of up to 1750 kPa (17.5 bar) overpressure.
2. Actuate starter for approx. 4 seconds with throttle valve fully open – minimum engine speed 300 rpm. The pressure difference between the individual cylinders should not exceed 100 kPa (1 bar).

Installation Procedure

1. Insert fuel pump relay in base and close relay holder cover.
2. Connect wiring harness plug to DIS ignition module.
3. Install spark plugs with KM-194-E into cylinder head – **Tighten**
Tightening torque 25 Nm / 18 lb. ft.
4. Connect spark plug connectors.

Engine Loss of Compression Test

Engine at operating temperature (oil temperature 80 °C).

Removal Procedure

1. Detach spark plug connectors, remove spark plugs with KM-194-E.
2. Remove fluid filler opening sealing cap, coolant compensation tank sealing cap and oil dipstick.
3. Remove upper part of toothed belt cover – see operation *Toothed Belt Cover – Upper Part, Remove and Install*.

Adjust

1. Set piston of 1st cylinder to TDC position. To determine TDC position – see operation *Timing Check*.

Installation Procedure

1. Connect pressure loss tester to compressed air system and calibrate.
2. Screw connector into spark plug bore of 1st cylinder and connect pressure loss tester with connector (observe manufacturer's instructions).

Important: The crankshaft is not permitted to rotate during the test procedure.

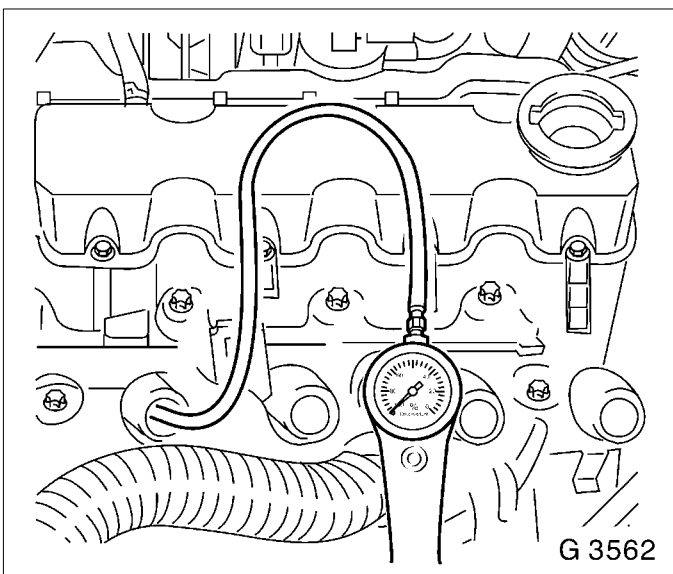

Inspect

1. Air outlet at: inlet or exhaust side, compensation tank and crankcase housing. Max. difference in pressure between individual cylinders: 10%. The max. pressure loss of a cylinder should not exceed 25%.
2. Check pressure loss at 3rd, 4th and 2nd cylinders analogously. Bring piston of cylinder to be checked in "ign. TDC" position, ignition sequence: 1-3-4-2.
3. Determine "ign. TDC" position by placing guide marks on camshaft sprocket.
4. Further turn crankshaft 180° in engine rotational direction (corresponds to 90° at camshaft sprocket) up to camshaft sprocket guide mark and align toothed belt cover.
5. Determine the "ign. TDC" position for 4th and 2nd cylinders analogously. Turn crankshaft slowly and uniformly.

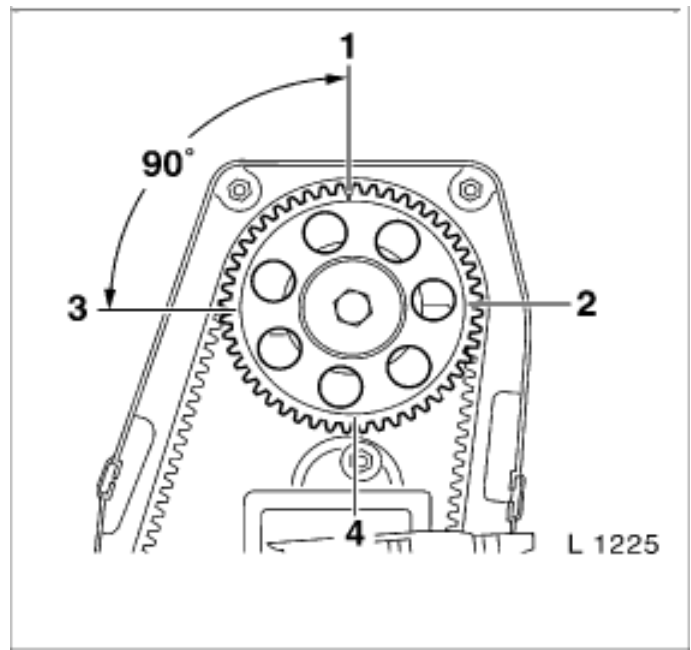

Installation Procedure

1. Install upper part of toothed belt cover – see operation *Toothed Belt Cover – Upper Part, Remove and Install*.
2. Install park plugs in cylinder head using KM-194-E.
Tighten
Tightening torque of spark plugs is 25 Nm / 18.5 lb. ft.
3. Attach spark plug connector, fluid filler opening sealing cap, coolant compensation tank sealing cap and oil dip stick.

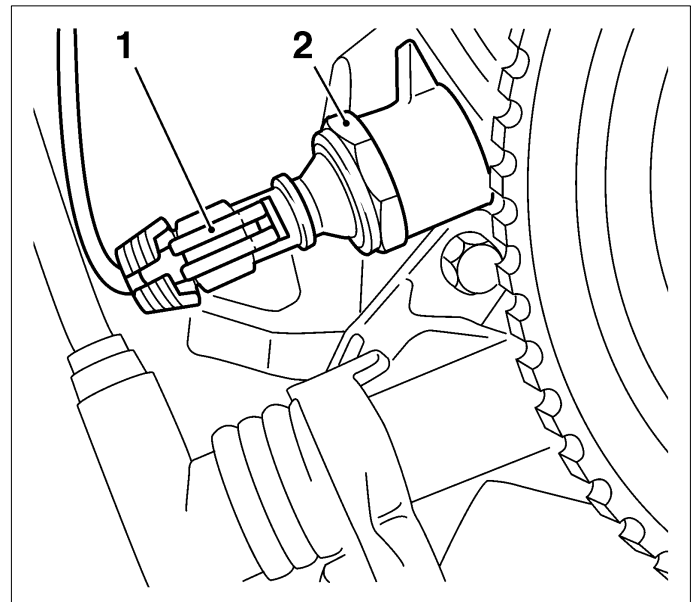

Oil Pressure Check

Removal Procedure

1. Disconnect wiring harness plug (1) from oil pressure switch, remove oil pressure switch (2) – place collecting basin underneath.

Inspect

1. Check oil pressure with KM-498-B (3) and KM-135 (4). The oil pressure should be approx. 150 kPa (1.5 bar) at idling speed with an oil temperature of 80 °C.

Installation Procedure

1. Attach oil pressure switch to oil pump with new seal ring.
Tighten
Tightening torque 30 Nm / 22 lb. ft.
2. Connect wiring harness plug to oil pressure switch.
3. Check engine oil level and correct if necessary.

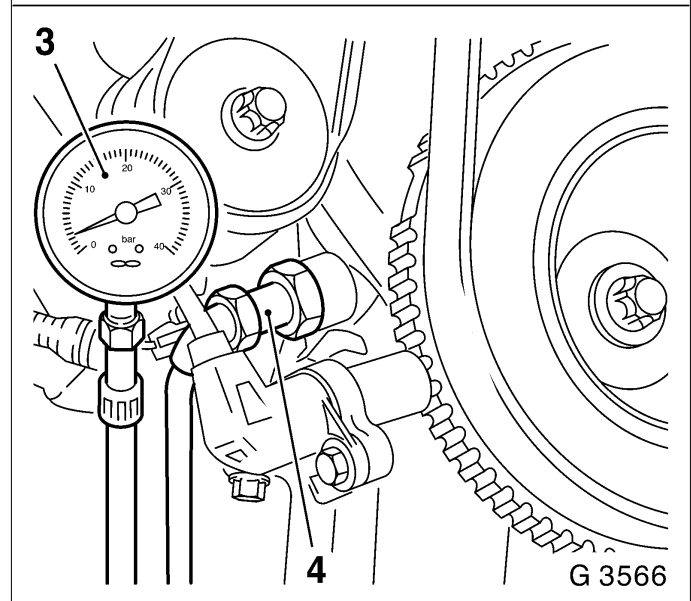

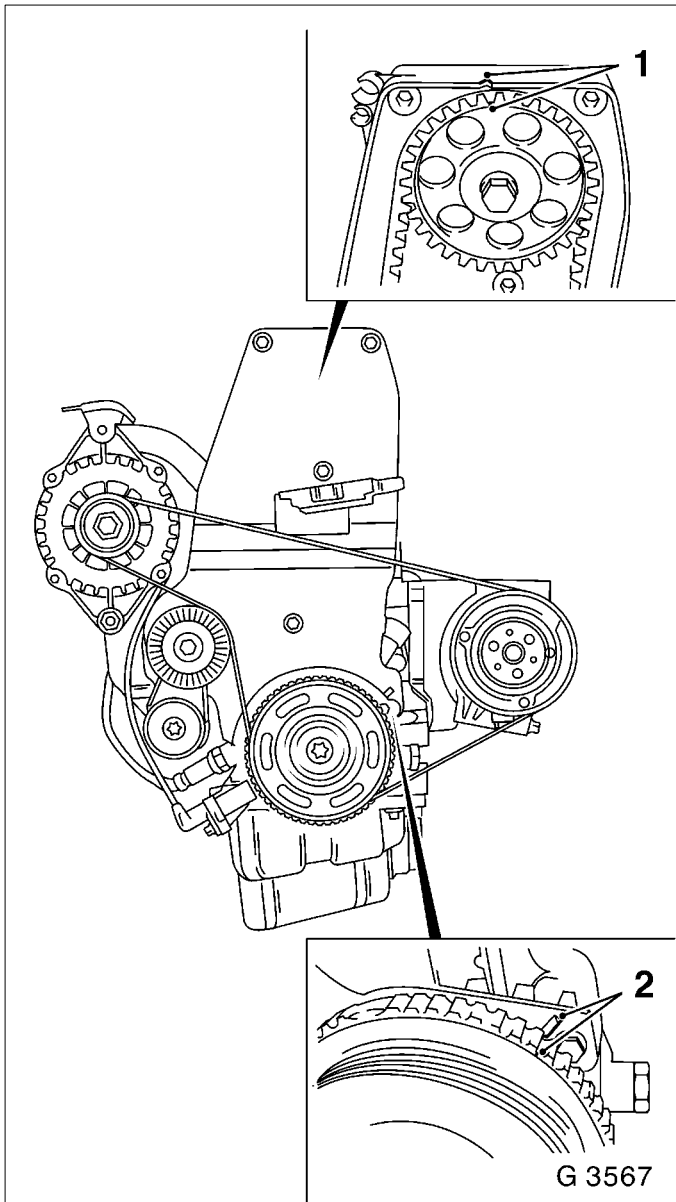

Valve Timing, Check

Removal Procedure

1. Disconnect ground cable from battery.
2. Remove upper part of toothed belt cover – see operation *Toothed Belt Cover – Upper Part, Remove and Install*.

Inspect

1. At fastening bolt of toothed belt drive gear, turn crankshaft in engine rotational direction to "1st cylinder TDC" (marking 2). At the same time, notches (1) on camshaft pulley and rear toothed belt cover must align. Turn crankshaft slowly and uniformly.
2. If the timing marks do not align – see operation *Valve Timing, Adjust*.

Installation Procedure

1. Install upper part of toothed belt cover – see operation *Toothed Belt Cover – Upper Part, Remove and Install*.
2. Connect ground cable to battery.

Valve Timing, Adjust

Notice: Adjustment is carried out with the engine cold – at room temperature.

Removal Procedure

1. Disconnect ground cable from battery.
2. Remove upper part of toothed belt cover – see operation *Toothed Belt Cover – Upper Part, Remove and Install*.
3. Remove ribbed V-belt – see operation *Ribbed V-belts, Remove and Install*.
4. Remove lower part of toothed belt cover – see operation *Toothed Belt Cover – Lower Part, Remove and Install*.
5. Remove engine bleeding hose (1) from camshaft housing cover.
6. Remove wiring trough (2) from camshaft housing cover.
7. Remove camshaft housing cover (3) from camshaft housing.

Adjust

1. Screw fastening bolt for toothed belt drive gear into crankshaft and turn crankshaft in engine rotational direction until pointer (4) on toothed belt drive gear is flush with mark on oil pump housing.
2. Move toothed belt tension roller against spring force upward until bore holes align.
3. Fix toothed belt tension roller in place with suitable drift (5).
4. Mark running direction of toothed belt and remove toothed belt.

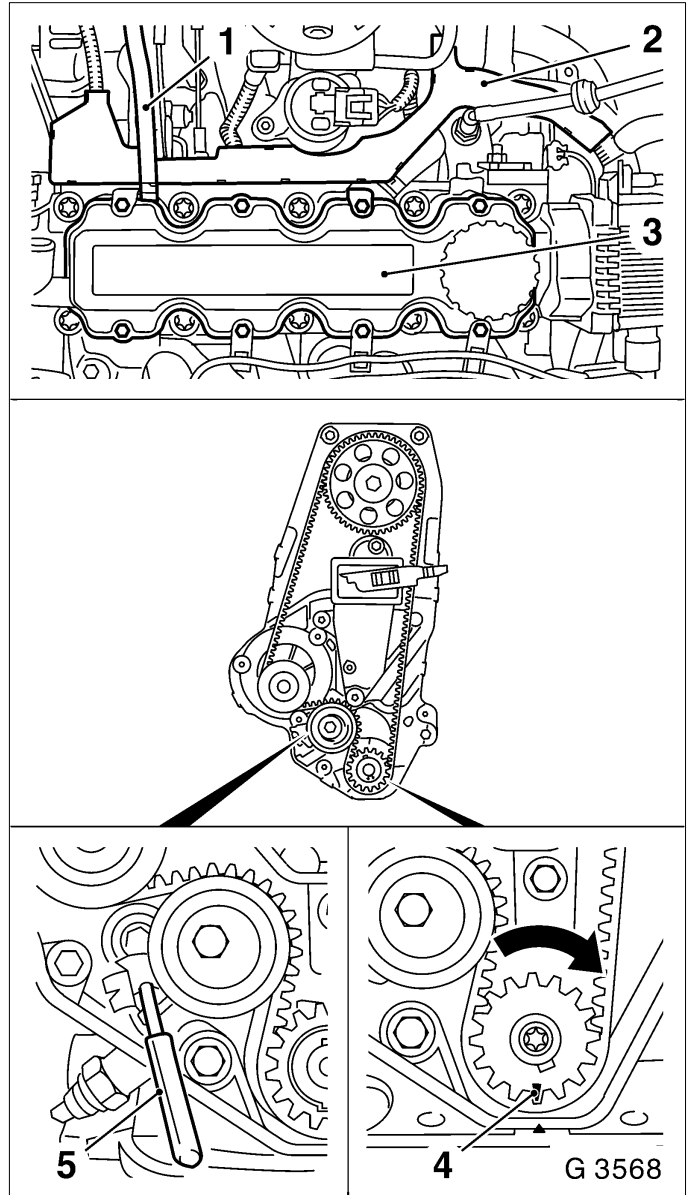

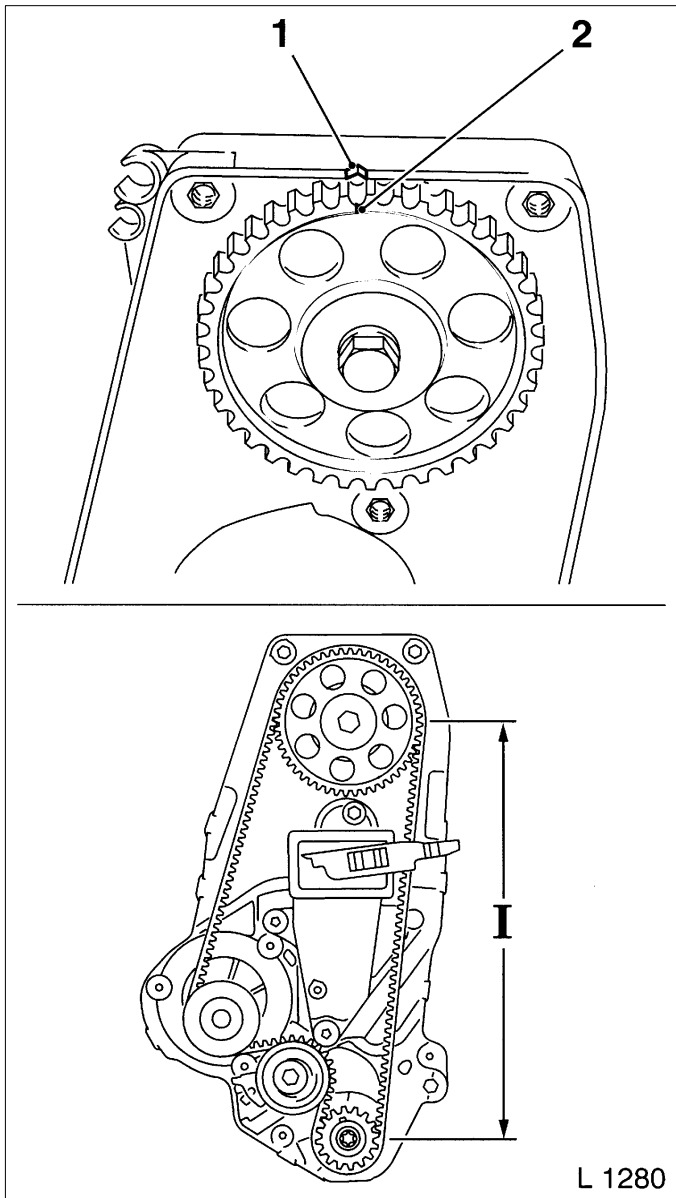
**Adjust**

1. At hex of camshaft, turn camshaft sprocket (short way) to mark. Notch (2) on camshaft sprocket must align with mark (1) on rear toothed belt cover.

Installation Procedure

1. Attach toothed belt – ensure that tension side (I) is taut. Note running direction of toothed belt.
2. Remove drift from toothed belt tension roller.
3. Adjust toothed belt tension – see operation *Toothed Belt Tension, Adjust*.
4. Install camshaft housing cover at camshaft housing –
Tighten
Tightening torque 8 Nm / 6 lb. ft.
5. Attach wiring trough to camshaft housing.
Tighten
Tightening torque 8 Nm / 6 lb. ft.
6. Attach engine bleeding hose to camshaft housing cover.

Removal Procedure

1. Remove fastening bolt from toothed belt drive gear.

Installation Procedure

1. Install lower part of toothed belt cover – see operation *Toothed Belt Cover – Lower Part, Remove and Install*.
2. Install ribbed V-belt – see operation *Ribbed V-belt, Remove and Install*.
3. Install upper part of toothed belt cover – see operation *Toothed Belt Cover – Upper Part, Remove and Install*.
4. Connect ground cable to battery.

Toothed Belt Tension, Check

Notice: Testing is performed with the engine cold – at room temperature.

Removal Procedure

1. Disconnect ground cable from battery.
2. Remove upper part of toothed belt cover – see operation *Toothed Belt Cover – Upper Part, Remove and Install*.
3. Remove ribbed V-belts – see operation *Ribbed V-belts, Remove and Install*.
4. Remove lower part of toothed belt cover – see operation *Toothed Belt Cover – Lower Part, Remove and Install*.

Adjust

1. Screw fastening bolts of toothed belt drive gear into crank shaft and turn crankshaft in engine rotational direction until pointer (3) aligns with mark on oil pump housing. At the same time, notch (2) on camshaft pulley must be aligned with mark (1) on rear toothed belt cover.

Inspect

1. The toothed belt tension is correctly adjusted when the pointer (4) of the movable part of the toothed belt tension roller aligns with notch (arrow).
2. If the toothed belt tension is not correctly adjusted – see operation *Toothed Belt Tension, Adjust*.

Removal Procedure

1. Remove fastening bolt from toothed belt drive gear.

Installation Procedure

1. Install lower part of toothed belt cover – see operation *Toothed Belt Cover – Lower Part, Remove and Install*.
2. Install ribbed V-belt – see operation *Ribbed V-belt, Remove and Install*.
3. Install upper part of toothed belt cover – see operation *Toothed Belt Cover – Upper Part, Remove and Install*.
4. Connect ground cable to battery.

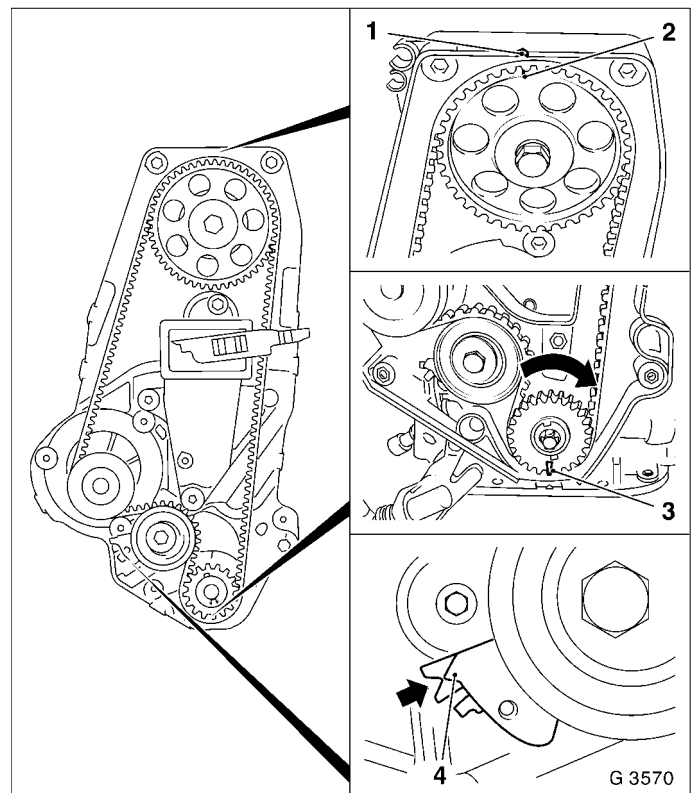

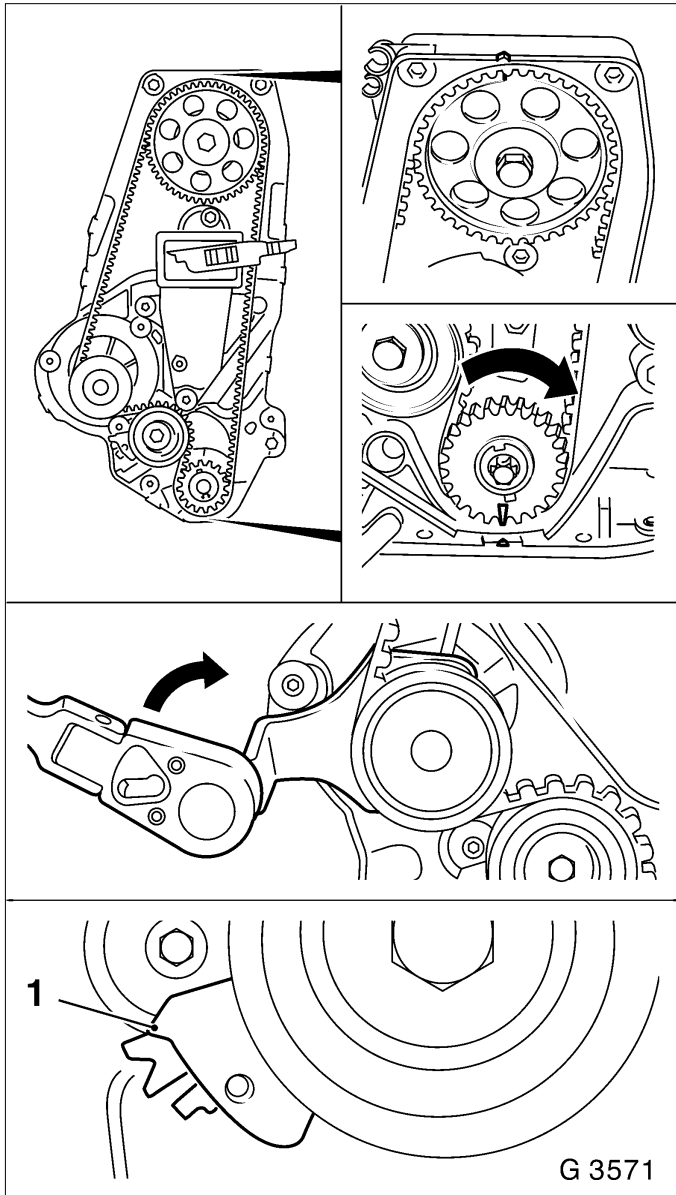

Toothed Belt Tension, Adjust

Notice: Testing is performed with the engine cold – at room temperature.

Removal Procedure

1. Remove upper part of toothed belt cover – see operation *Toothed Belt Cover – Upper Part, Remove and Install*.
2. Remove ribbed V-belts – see operation *Ribbed V-belts, Remove and Install*.
3. Remove lower part of toothed belt cover – see operation *Toothed Belt Cover – Lower Part, Remove and Install*.

Adjust

1. Screw fastening bolt for toothed belt drive gear into crankshaft and turn crankshaft in engine rotational direction until pointer on toothed belt drive gear is flush with mark on oil pump housing. At the same time, notch on camshaft pulley must be flush with mark on rear toothed belt cover.
2. Release fastening bolts for coolant pump.
3. Tension toothed belt by turning coolant pump in direction of arrow (clockwise) with KM-421-A until pointer (1) is at right stop.

Adjust

1. Turn crankshaft two revolutions (720°) in engine rotational direction, until timing marks align. Turn crankshaft slowly and uniformly and do not change position of coolant pump.
2. Reduce toothed belt tension by turning coolant pump in direction of arrow with KM-421-A until pointer (1) and notch (2) on toothed belt tension roller carrier plate align.
3. Set crankshaft another two revolutions (720°) in engine rotational direction to mark "1st cylinder ignition TDC" and check adjustment of toothed belt tension roller. If marks do not align, repeat adjustment procedure.

Tighten

Tighten coolant pump to cylinder block bolts to 8 Nm / 6 lb. ft.

Installation Procedure

1. Remove fastening bolt from toothed belt drive gear and install toothed belt cover, lower part – see operation *Toothed Belt Cover, Lower Part, Remove and Install*.
2. Install ribbed V-belt – see operation *Ribbed V-belt, Remove and Install*.
3. Install upper part of toothed belt cover – see operation *Toothed Belt Cover – Upper Part, Remove and Install*.
4. Check cooling system for leaks – see operation in Section 3, Engine Cooling - *Cooling System, Check for Leaks*.

Repair Instructions**Engine Timing Side****Ribbed V-belt, Remove and Install****Removal Procedure**

1. Remove the fan guard. Refer to procedure *Fan Guard Replacement*.
2. Loosen the generator mounting bolts.
3. Move the generator inward to loosen the tension on the drive belt.
4. Slide the belt off the pulleys and over the fan blades.
5. Inspect the drive belt for:
 - Cracks
 - Glazing
 - Tears or cuts
 - Excessive wear

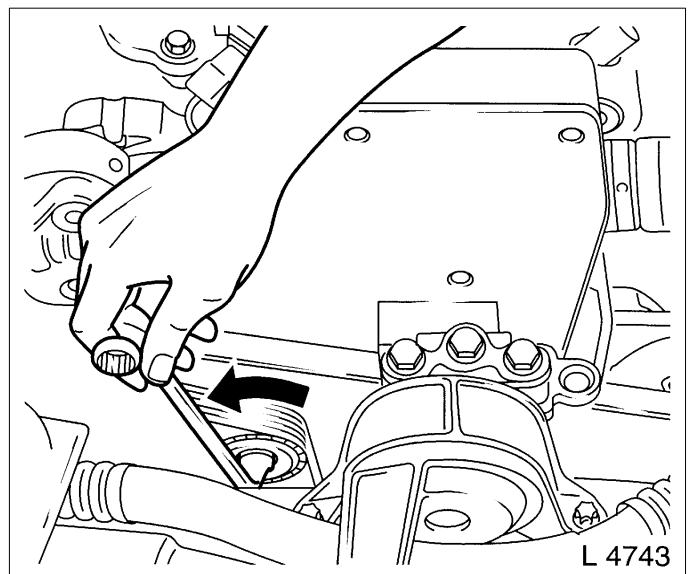
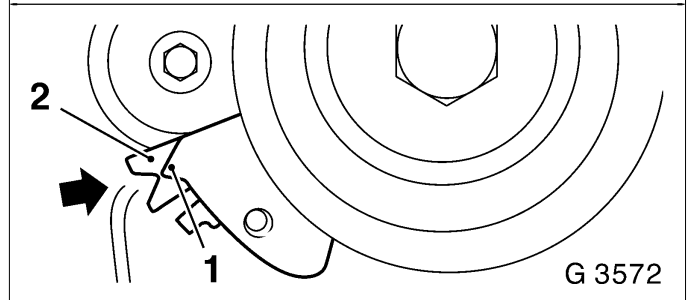
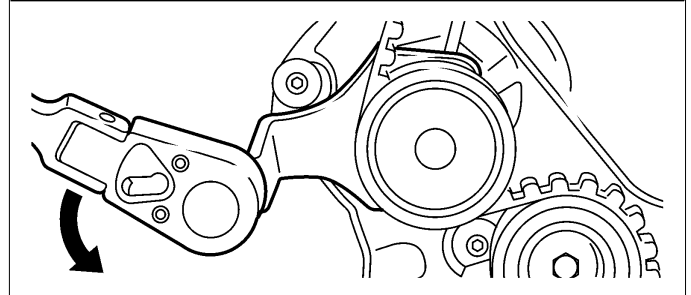
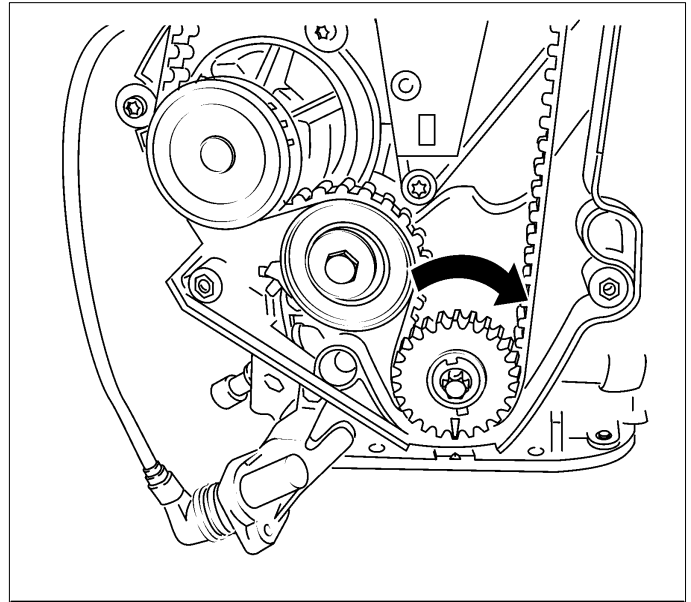

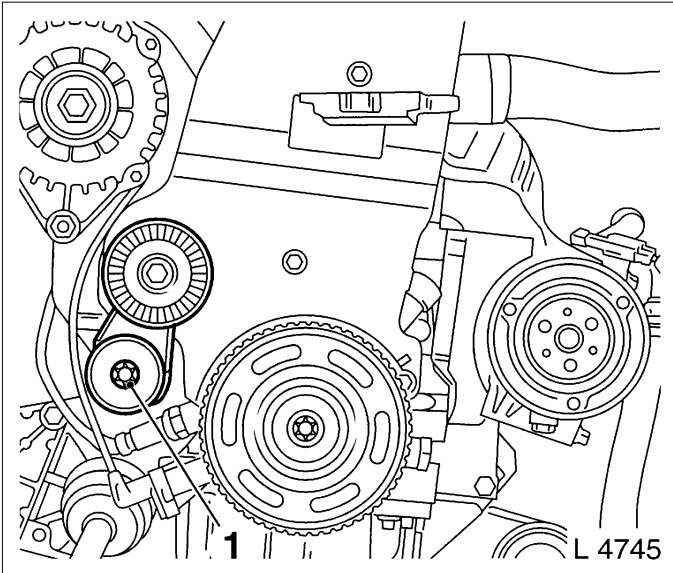

Installation Procedure

Tools Required:

- 6" Steel Rule

1. Slide the belt over the fan blades and route it over the pulleys.
2. Move the generator outward until the fan belt measures approximately 1/2 inch (13 mm) deflection.

Notice: Refer to *Fastener Notice*

3. While maintaining tension on the drive belt, tighten the generator mounting bolts.

Tighten

Tighten the lower generator mounting bolt to 50 Nm / 37 lb. ft.

Tighten the upper generator mounting bolt to 25 Nm / 18 lb. ft.

4. Verify that the belt tension is correct with the ruler.
5. Install the fan guard. Refer to procedure *Fan Guard Replacement*.

Installation Procedure

1. Install lower engine splash guard.
2. Install ribbed V-belt – see operation *Ribbed V-belt, Remove and Install*.

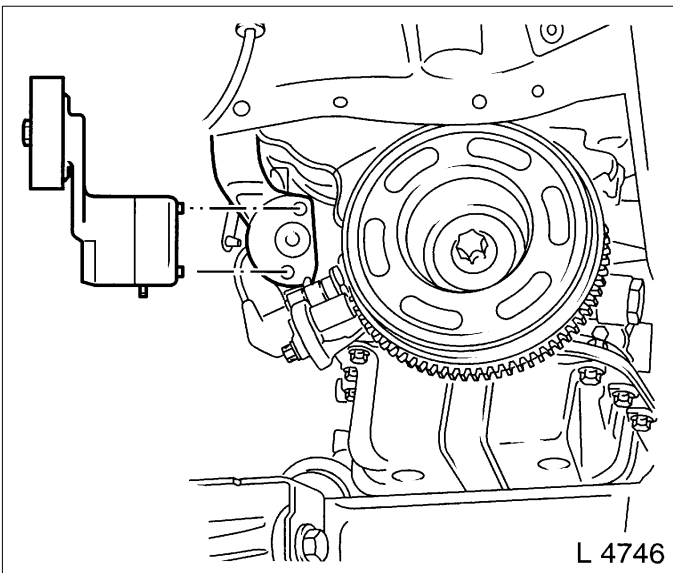

Toothed Belt Cover, Upper Part, Remove and Install

Removal Procedure

1. Remove fastening bolts (1) and remove upper part of toothed belt cover from rear toothed belt cover.

Installation Procedure

1. Attach upper part of toothed belt cover to rear toothed belt cover.

Tighten

Tightening torque 4 Nm / 3 lb. ft.

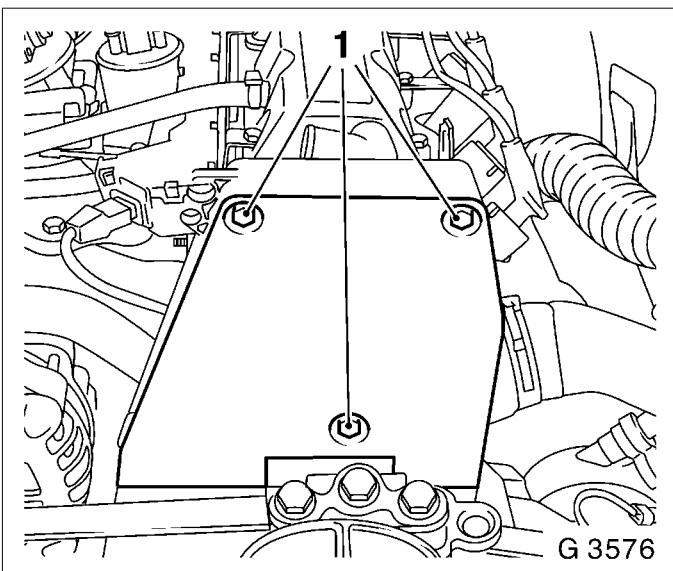

Toothed Belt Cover, Lower Part, Remove and Install

Removal Procedure

1. Remove upper part of toothed belt cover – see operation *Toothed Belt Cover – Upper Part, Remove and Install*.
2. Remove ribbed V-belts – see operation *Ribbed V-belts, Remove and Install*.
4. Lever closure plug (arrow) out of opening with screw driver. Lock drive disk or flywheel with KM-911 (1).
5. Detach increment disc (2) from crankshaft.
6. Remove fastening bolts (3) and remove lower part of toothed belt cover from rear toothed belt cover.

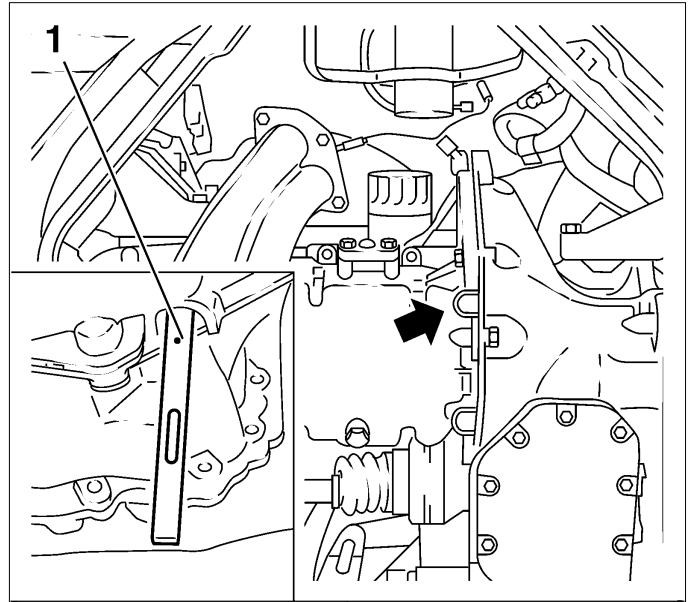

Installation Procedure

1. Attach lower part of toothed belt cover to rear toothed belt cover.
Tighten
Tightening torque 4 Nm / 3 lb. ft.
2. Attach increment disc with new fastening bolt to crankshaft.
Tighten
Tightening torque 95 Nm / 70 lb. ft. + 30° + 15°.
3. Remove Locking Tool KM-911 and insert new closure plug in aperture.
4. Install ribbed V-belt – see operation *Ribbed V-belt, Remove and Install*.
5. Install upper part of toothed belt cover – see operation *Toothed Belt Cover – Upper Part, Remove and Install*.

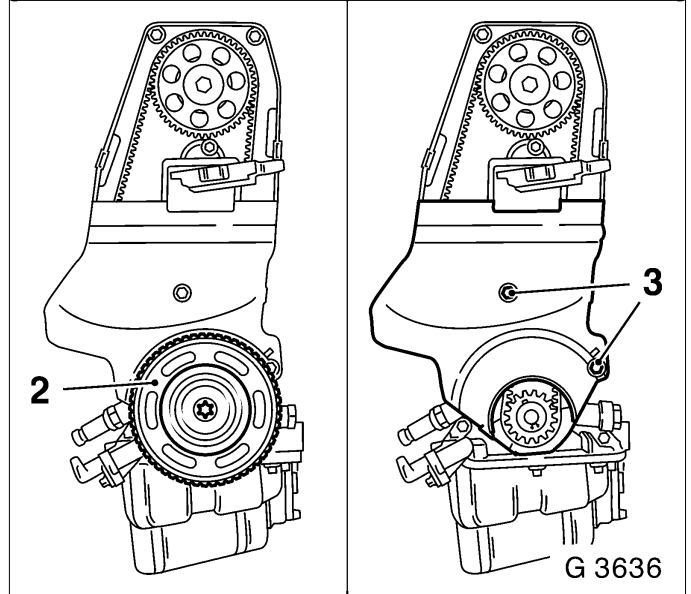

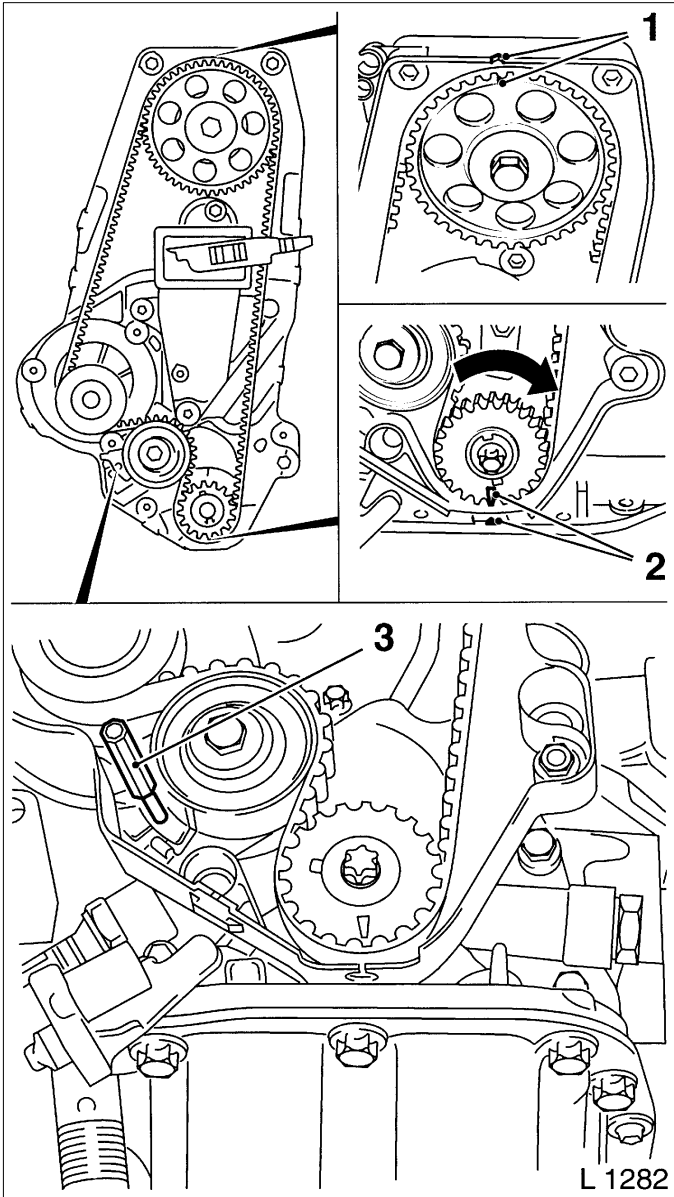

Toothed Belt, Remove and Install

Removal Procedure

1. Remove upper part of toothed belt cover – see operation *Toothed Belt Cover – Upper Part, Remove and Install*.
2. Remove ribbed V-belts – see operation *Ribbed V-belts, Remove and Install*.
3. Remove lower part of toothed belt cover – see operation *Toothed Belt Cover – Lower Part, Remove and Install*.

Adjust

1. Screw fastening bolt for toothed belt drive gear into crank shaft and turn crankshaft in engine rotational direction until marks (2) on toothed belt drive gear and oil pump housing are flush. At the same time, notches (1) on camshaft pulley and rear toothed belt cover must be flush. Turn crankshaft slowly and smoothly.

Removal Procedure

1. Move toothed belt tension roller upward against spring force until bore holes align. Fix toothed belt tension roller in place with suitable drift (3).
2. Mark running direction of the toothed belt for identification and remove toothed belt.

Installation Procedure

1. Check toothed belt for wear – replace if necessary. Install toothed belt – ensure that tensioned side (I) is taut.
2. Observe timing marks. Adjust toothed belt tension – see operation *Toothed Belt Tension, Adjust*.
3. Remove fastening bolt from toothed belt drive gear and install toothed belt cover, lower part – see operation *Toothed Belt Cover, Lower Part, Remove and Install*.
4. Install ribbed V-belt – see operation *Ribbed V-belt, Remove and Install*.
5. Install upper part of toothed belt cover – see operation *Toothed Belt Cover – Upper Part, Remove and Install*.

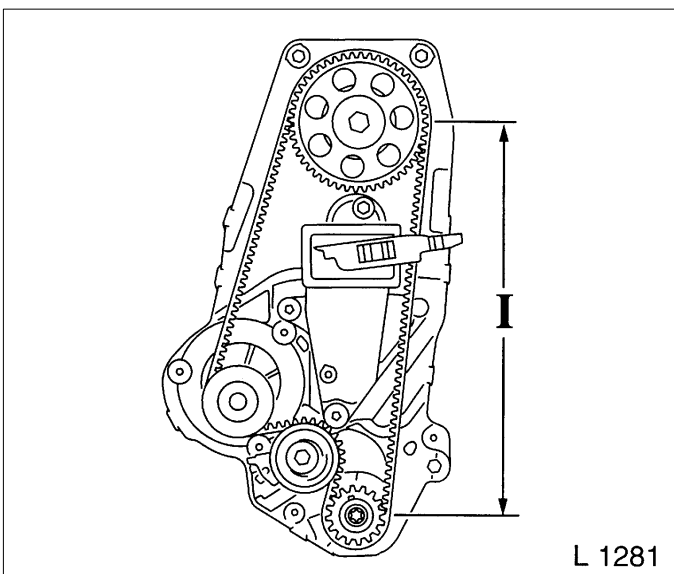

L 1281

Toothed Belt Tension Roller, Remove and Install

Removal Procedure

1. Remove upper part of toothed belt cover – see operation *Toothed Belt Cover – Upper Part, Remove and Install*.
2. Remove ribbed V-belts – see operation *Ribbed V-belts, Remove and Install*.
3. Remove lower part of toothed belt cover – see operation *Toothed Belt Cover – Lower Part, Remove and Install*.
4. Remove toothed belt – see operation *Toothed Belt, Remove and Install*.
3. Remove toothed belt tension roller (1) from oil pump.

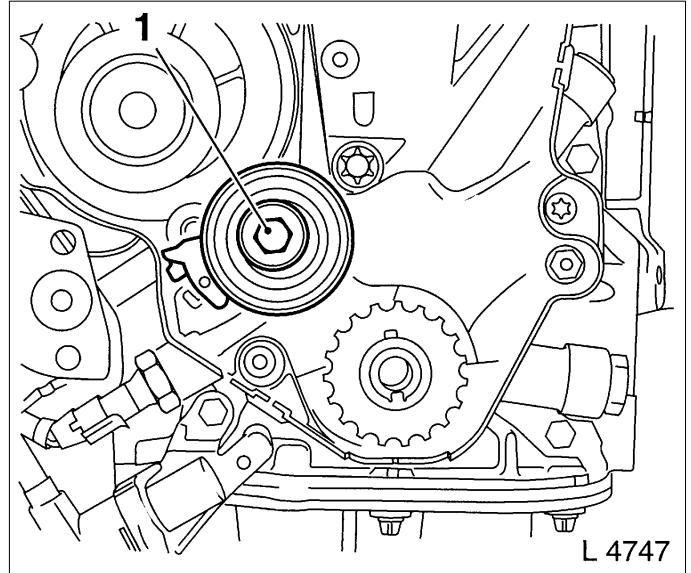

L 4747

Installation Procedure

1. Install toothed belt tension roller – make sure that lug (1) of toothed belt tension roller base plate engages in groove (2) of oil pump.
2. Attach toothed belt tension roller to oil pump.
Tighten
Tightening torque 20 Nm / 15 lb. ft.
3. Install toothed belt – see operation *Toothed Belt, Remove and Install*.
4. Install lower part of toothed belt cover – see operation *Toothed Belt Cover – Lower Part, Remove and Install*.
6. Install ribbed V-belt – see operation *Ribbed V-belt, Remove and Install*.
7. Install upper part of toothed belt cover – see operation *Toothed Belt Cover – Upper Part, Remove and Install*.

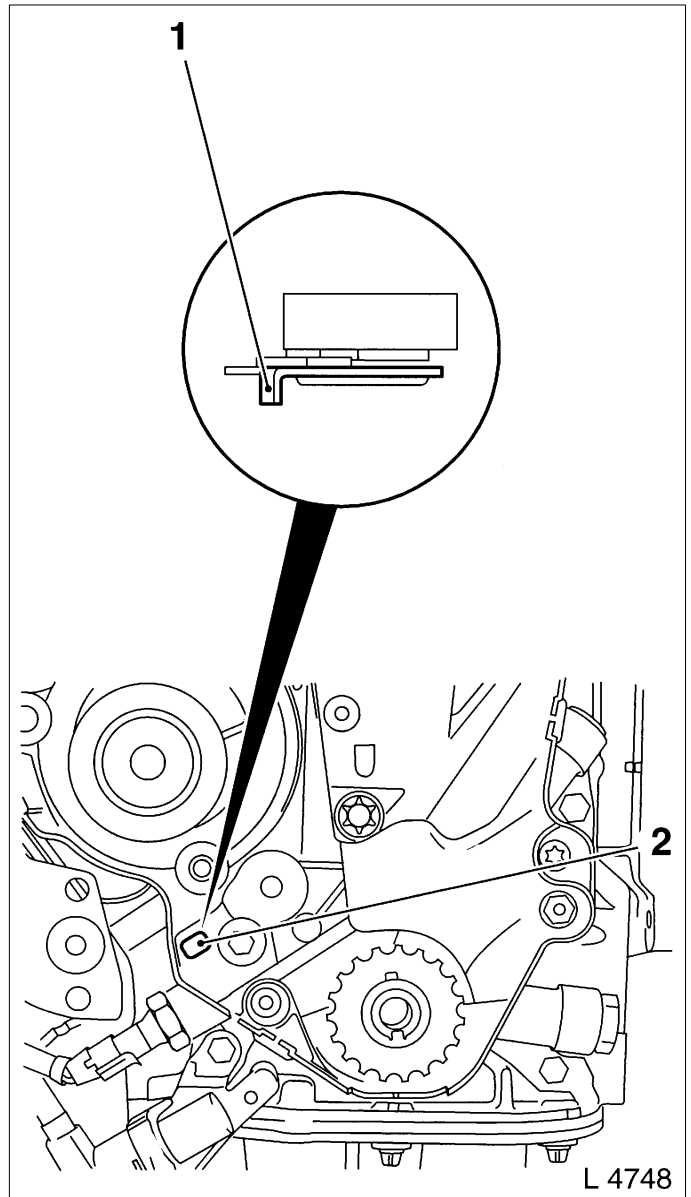

L 4748

Seal Ring in Front Camshaft Housing, Replace

Removal Procedure

1. Remove upper part of toothed belt cover – see operation *Toothed Belt Cover – Upper Part, Remove and Install*.
2. Remove ribbed V-belts – see operation *Ribbed V-belts, Remove and Install*.
3. Remove lower part of toothed belt cover – see operation *Toothed Belt Cover – Lower Part, Remove and Install*.
4. Remove toothed belt – see operation *Toothed Belt, Remove and Install*.
5. Remove engine vent hose from camshaft housing cover.
6. Detach wiring trough from camshaft housing cover.
7. Remove camshaft housing cover from camshaft housing.
8. Remove camshaft sprocket (1) from camshaft – counterhold with open-ended spanner on hex of camshaft.
9. Edge out seal ring (2) with suitable tool.

Important: Do not damage sealing surfaces.

Installation Procedure

1. Lightly coat sealing lip of seal ring with silicon grease (white). Press seal ring with KM-422 (3) in camshaft housing – use bolt and washer of camshaft pulley.

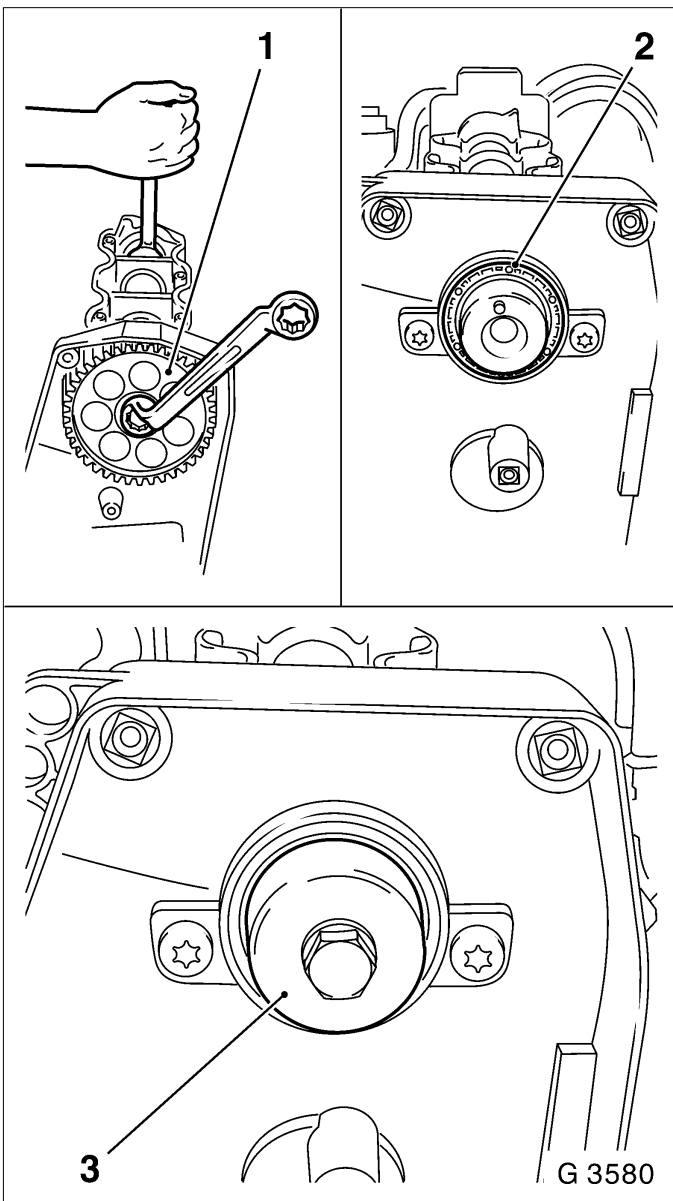

Removal Procedure

1. Remove engine vent hose from camshaft housing cover.
2. Detach wiring trough from camshaft housing cover.
3. Remove camshaft housing cover from camshaft housing.
4. Remove camshaft sprocket (1) from camshaft – counterhold with open-ended spanner on hex of camshaft.
5. Edge out seal ring (2) with suitable tool.

Important: Do not damage sealing surfaces.

Installation Procedure

1. Lightly coat sealing lip of seal ring with silicon grease (white).
2. Press seal ring with KM-422 (3) in camshaft housing – use bolt and washer of camshaft pulley.
3. Attach camshaft sprocket to camshaft – counterhold with open-ended spanner on hex of camshaft.
Tighten
Tightening torque 45 Nm / 33 lb. ft.
4. Install camshaft housing cover at camshaft housing.
Tighten
Tightening torque 8 Nm / 6 lb. ft.
5. Attach engine bleeding hose to camshaft housing cover.
6. Install toothed belt – see operation *Toothed Belt, Remove and Install*.
7. Install lower part of toothed belt cover – see operation *Toothed Belt Cover – Lower Part, Remove and Install*.
8. Install ribbed V-belt – see operation *Ribbed V-belt, Remove and Install*.
9. Install upper part of toothed belt cover – see operation *Toothed Belt Cover – Upper Part, Remove and Install*.

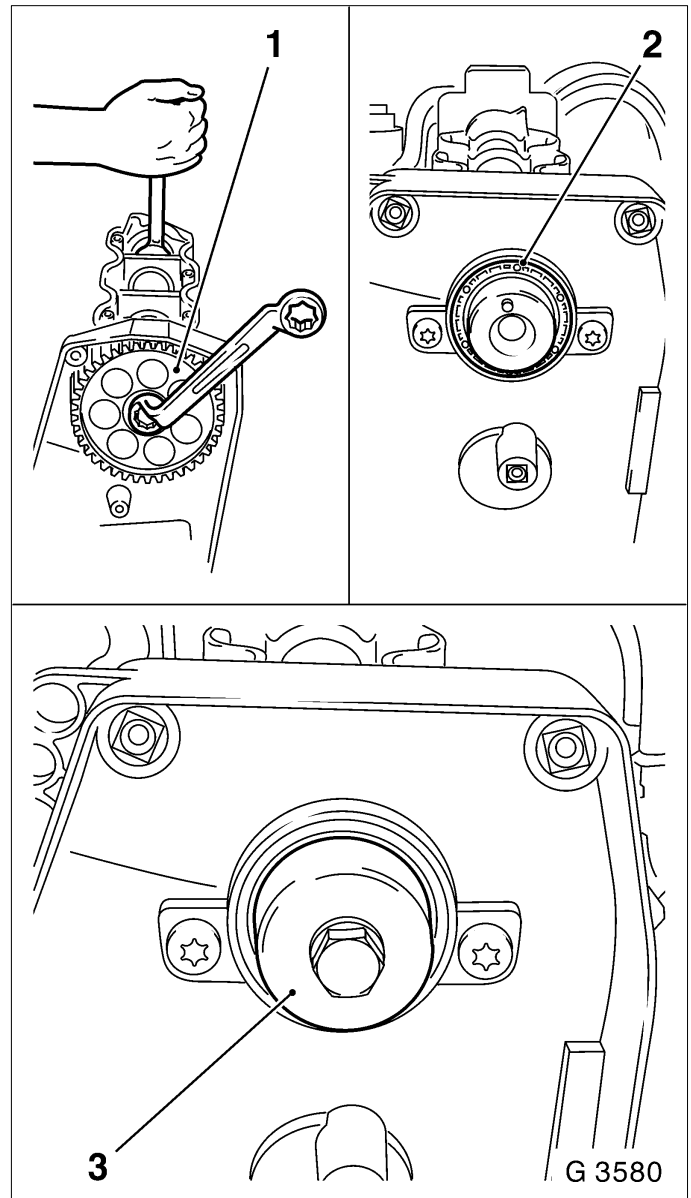

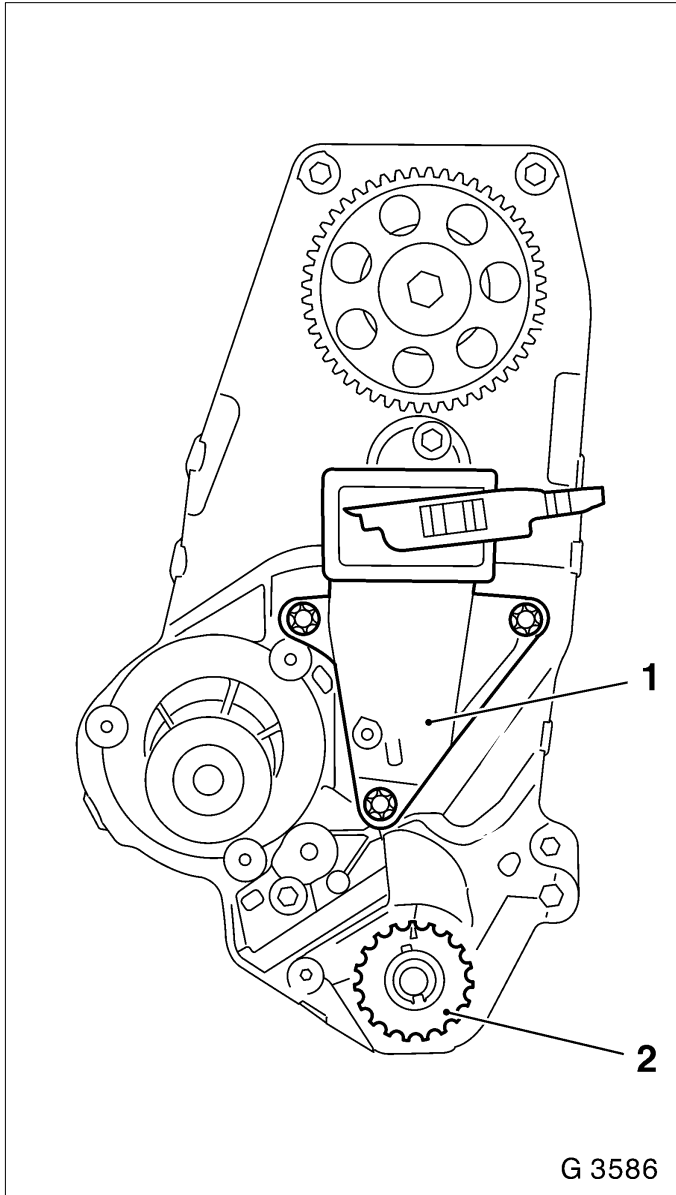

Rear Toothed Belt Cover, Remove and Install

Removal Procedure

1. Remove upper part of toothed belt cover – see operation *Toothed Belt Cover – Upper Part, Remove and Install*.
2. Remove ribbed V-belts – see operation *Ribbed V-belts, Remove and Install*.
3. Remove lower part of toothed belt cover – see operation *Toothed Belt Cover – Lower Part, Remove and Install*.
4. Remove toothed belt – see operation *Toothed Belt, Remove and Install*.
5. Remove toothed belt tension roller – see operation *Toothed Belt Tension Roller, Remove and Install*.
6. Remove toothed belt drive gear (2) from crankshaft.

Removal Procedure

1. Remove engine bleeding hose (1) from camshaft housing cover.
2. Remove camshaft housing cover (3) from camshaft housing.
3. Remove camshaft sprocket – counterhold with open-ended spanner on hex of camshaft.
4. Unclip cable for crankshaft pulse pickup from rear toothed belt cover.
5. Remove rear toothed belt cover (arrows) from oil pump and camshaft housing.

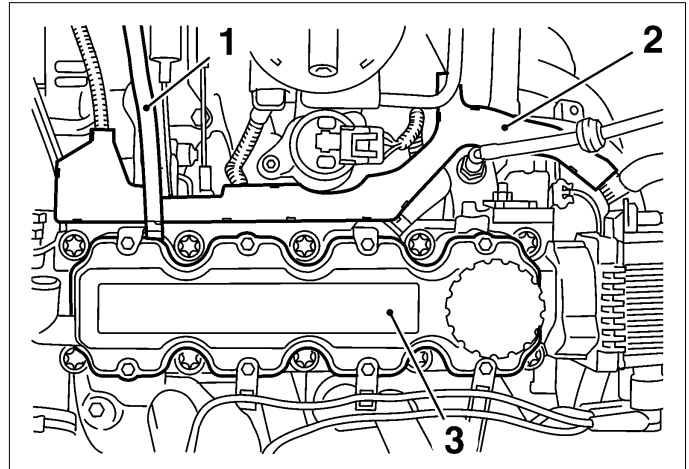

Installation Procedure

1. Attach rear toothed belt cover to oil pump and camshaft housing.
Tighten
Tightening torque 6 Nm / 4 lb. ft.
2. Clip cable for crankshaft pulse pickup to rear toothed belt cover – note cable routing.
3. Attach camshaft sprocket to camshaft – counterhold with open-ended spanner on hex of camshaft.
Tighten
Tightening torque 45 Nm / 33 lb. ft.
4. Install camshaft housing cover at camshaft housing.
Tighten
Tightening torque 8 Nm / 6 lb. ft.
5. Attach engine bleeding hose to camshaft housing cover.
6. Attach engine damping block support to cylinder block.
Tighten
Tightening torque 50 Nm / 37 lb. ft.

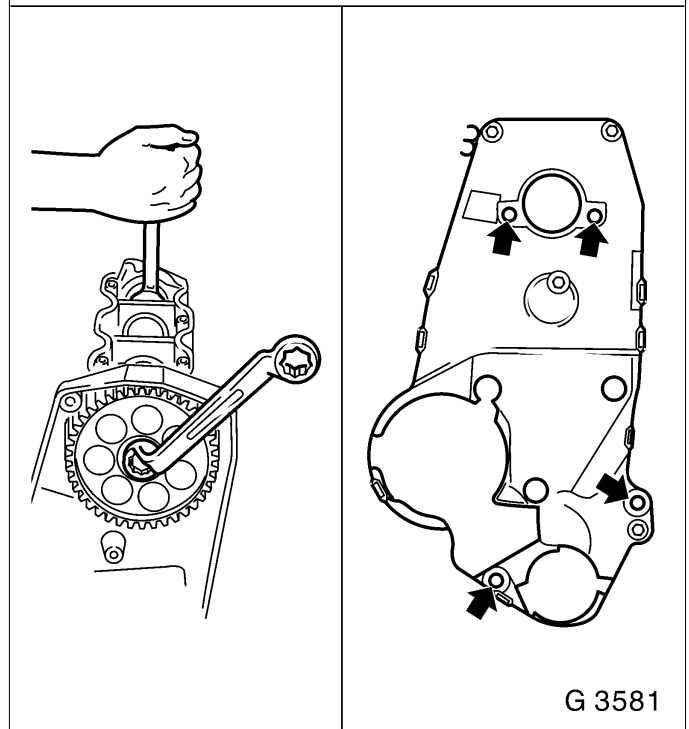

G 3581

7. Slide toothed belt drive gear onto crankshaft journal – note installation position.
8. Install toothed belt tension roller – see operation *Toothed Belt Tension Roller, Remove and Install*.
9. Install toothed belt – see operation *Toothed Belt, Remove and Install*.
10. Install lower part of toothed belt cover – see operation *Toothed Belt Cover – Lower Part, Remove and Install*.
11. Install ribbed V-belt – see operation *Ribbed V-belt, Remove and Install*.
12. Install upper part of toothed belt cover – see operation *Toothed Belt Cover – Upper Part, Remove and Install*.

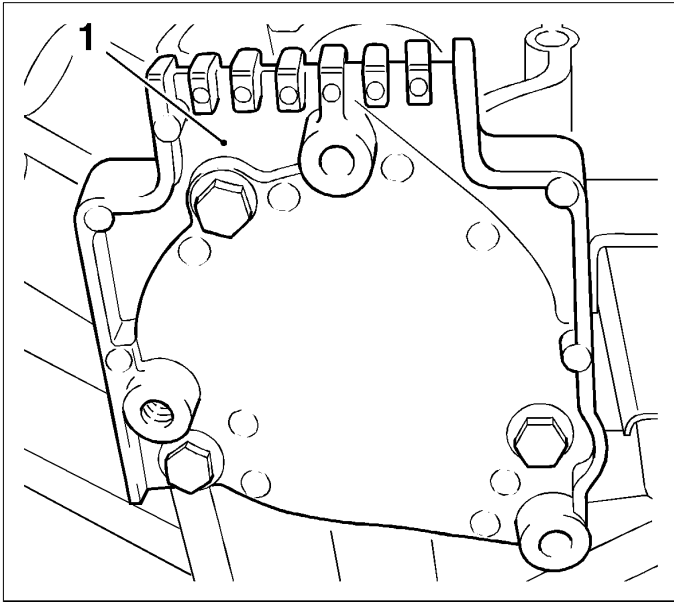

Cylinder Head

Seal Ring in Rear Camshaft Housing, Replace

Removal Procedure

1. Remove DIS ignition module – see operation *DIS Ignition Module, Remove and Install*.
2. Remove carrier plate (1) from camshaft housing.

Clean

1. Clean sealing surfaces and remove gasket remnants.

Installation Procedure

1. Coat seal ring (2) of carrier plate with silicone grease (white) and attach carrier plate to camshaft housing.

Tighten

Tightening torque 12 Nm / 9 lb. ft.

2. Install DIS ignition module – see operation *DIS Ignition Module, Remove and Install*.

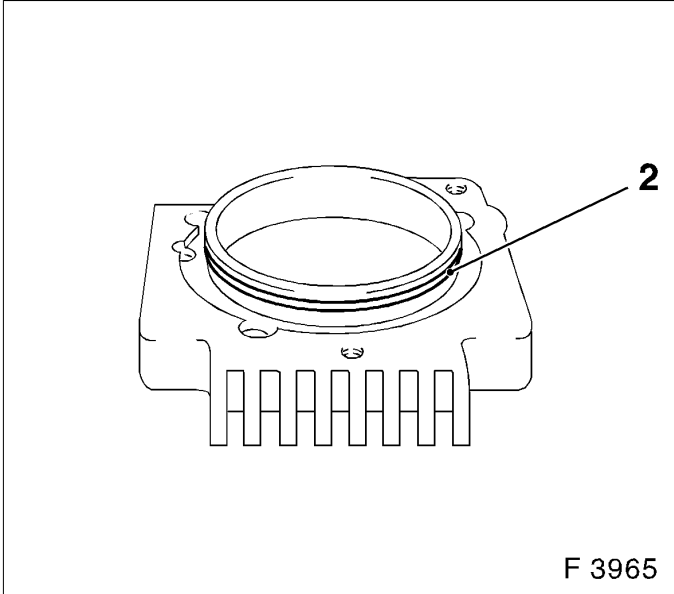

F 3965

Exhaust Manifold, Remove and Install

Removal Procedure

1. Disconnect spark plug connectors (2) from 1st, 2nd and 3rd cylinder.
2. Remove heat shields (3) of 2nd and 3rd cylinders with KM-834-A from cylinder head.
3. Remove heat shield (4) from exhaust manifold.
4. Remove exhaust manifold (5) from cylinder head.

Clean

1. Clean sealing surfaces and remove gasket remnants.

Installation Procedure

1. Attach exhaust manifold with new gasket and new nuts to cylinder head.

Tighten

Tightening torque 22 Nm / 16 lb. ft.

2. Attach heat shield to exhaust manifold.

Tighten

Tightening torque 8 Nm / 6 lb. ft.

3. Coat heat shields with assembly paste (white) and install in cylinder head with KM-834-A.

Tighten

Tightening torque 25 Nm / 18 lb. ft.

4. Connect spark plug connectors.

For version with hex bolts: Attach front exhaust pipe with new gasket and bolts coated with assembly paste (white) to exhaust manifold.

Tighten

Tightening torque 35 Nm / 26 lb. ft.

For version with hex nuts: Attach front exhaust pipe with new gasket and new nuts to exhaust manifold.

Tighten

Tightening torque 45 Nm / 33 lb. ft.

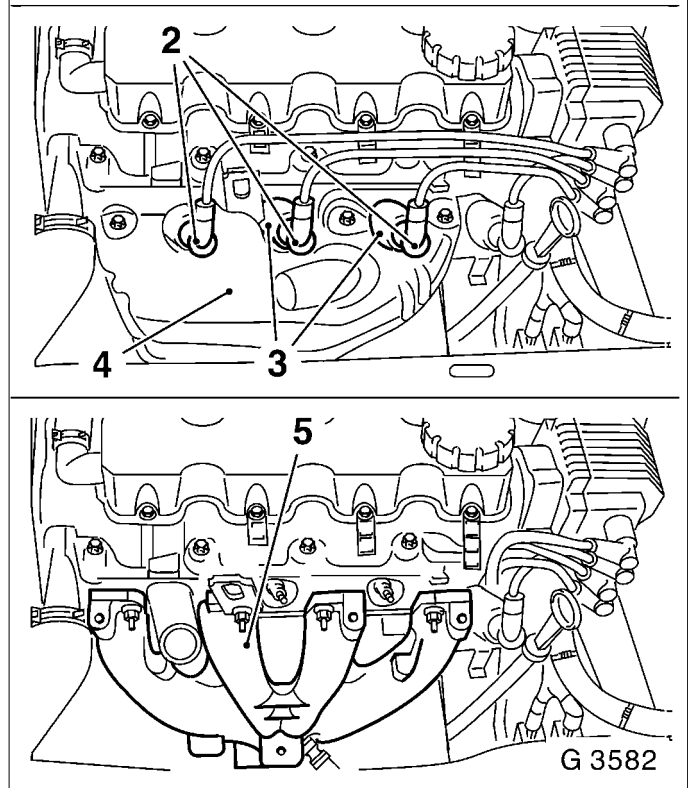

Intake Manifold, Remove and Install - Port Fuel Injected Models

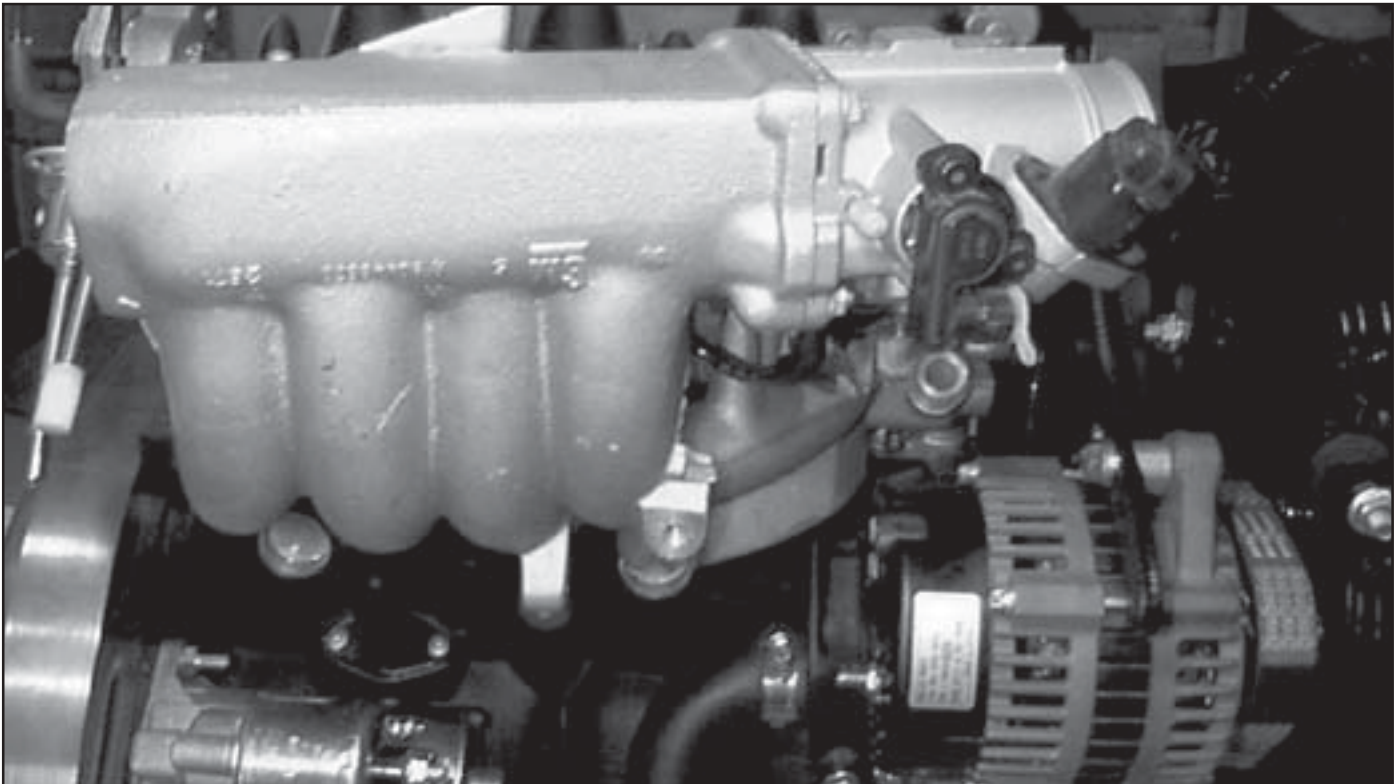

80361003

Important: Fuel leak – observe safety regulations and national legislation. Reduce fuel pressure with Pressure Tester KM–J–34730–91 via testing port – collect escaping fuel in suitable container.

Removal Procedure

1. Disconnect ground cable from battery.
2. Disconnect all electrical connectors from the sensors mounted on the intake manifold.
3. Disconnect fuel and vent lines.
4. Remove drive belts. Refer to *Drive Belt Replacement* in Section 2, Engine Cooling
5. Remove the Generator top mounting bolt and swing the generator rearward to gain access to intake manifold mounting bolts.
6. Remove the intake manifold mounting bolts, the intake manifold and gasket.
7. Clean sealing surfaces and remove gasket remnants.

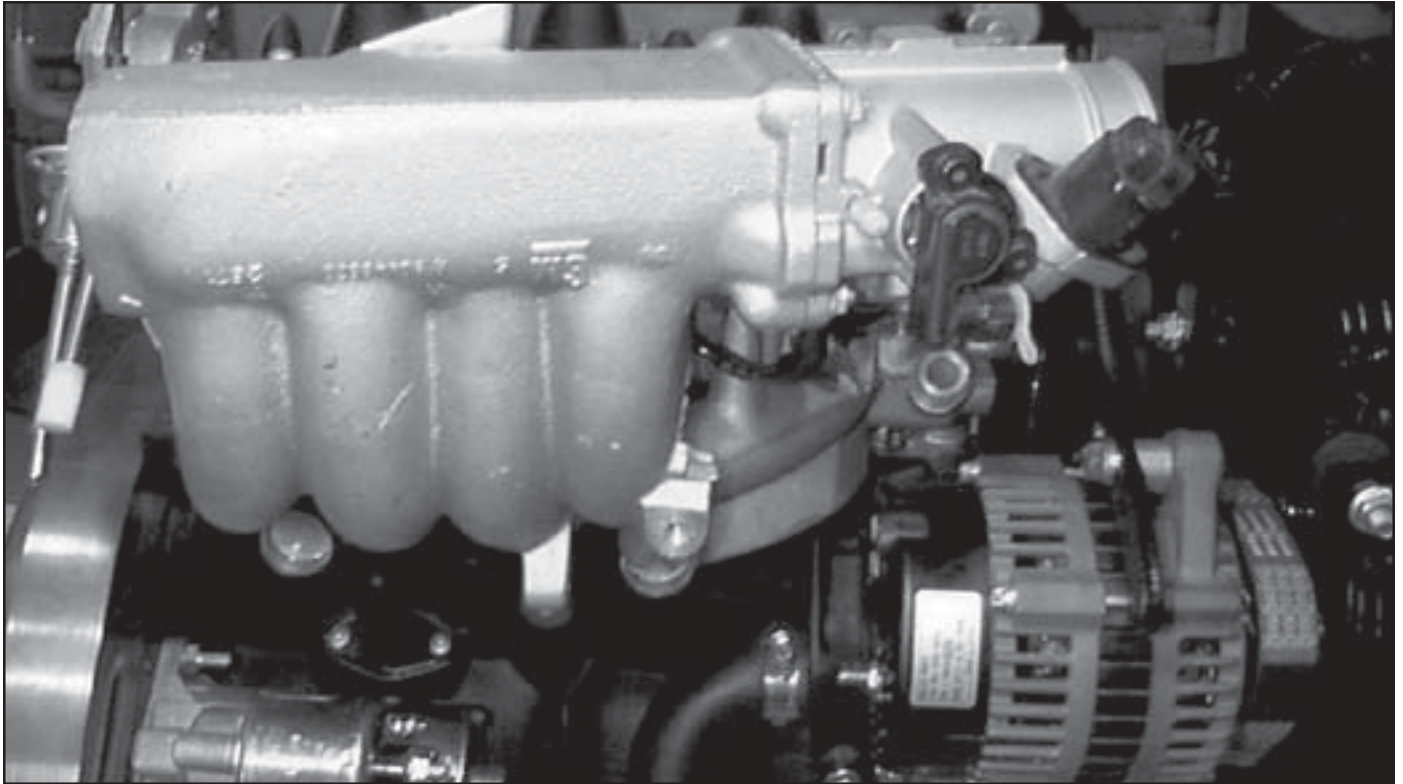
Intake Manifold, Remove and Install - Port Fuel Injected Models (Continued)

80361003

Installation Procedure

Notice: Refer to *Fastener Notice* on page 1-2.

1. Install the intake manifold, a new gasket, and the intake manifold mounting bolts.

Tighten

Tighten the intake manifold bolts to 22 N•m (16 lb ft).

2. Swing the generator forward into position and install the top mounting bolt.

Tighten

Tighten the top mounting bolt to 20 N•m (15 lb ft).

Tighten the bottom mounting bolt and nut to 35 N•m (26 lb ft).

3. Install the drive belt. Refer to *Drive Belt Replacement* in Engine Cooling.
4. Connect the fuel and vent lines.
5. Connect all electrical connectors to the sensors mounted on the intake manifold.
6. Connect ground cable to the battery.

Tighten

Tighten the battery side terminal bolts (if applicable) to 12 N•m (106 lb in).

Tighten the top terminal nuts (if applicable) to 18 N•m (13 lb ft).

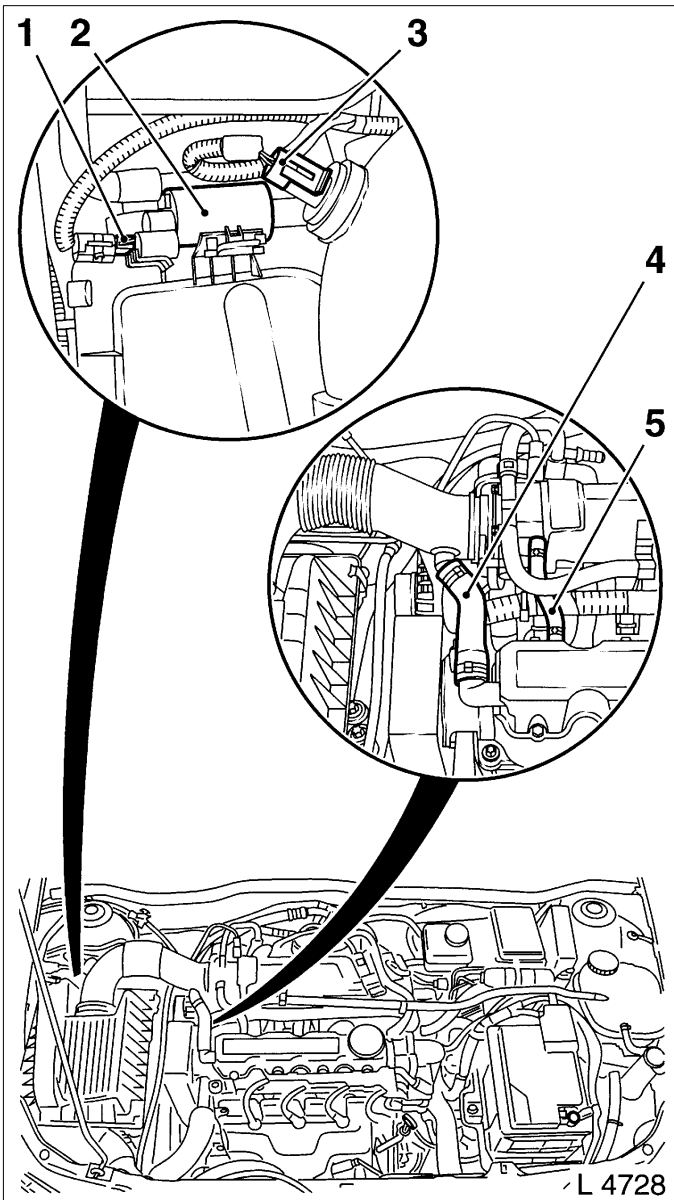

Intake Manifold, Remove and Install - Throttle Body Injected Models

Important: Fuel leak – observe safety regulations and national legislation. Reduce fuel pressure with Pressure Tester KM–J–34730–91 via testing port – collect escaping fuel in suitable container.

Removal Procedure

1. Disconnect ground cable from battery.
2. Open coolant drain bolt – collect escaping coolant.
3. Remove engine vent hoses (4) and (5) from camshaft housing cover.
4. Disconnect wiring harness plug (3) from intake air temperature sensor.
5. Disconnect wiring harness plug (1) from tank vent valve (2). Detach tank vent valve from air cleaner housing.
6. Remove ribbed V–belts – see operation *Ribbed V–belts, Remove and Install*.
7. Detach tank vent valve hose (6) from throttle body.
8. Detach coolant hoses (7) from throttle body and lay aside.

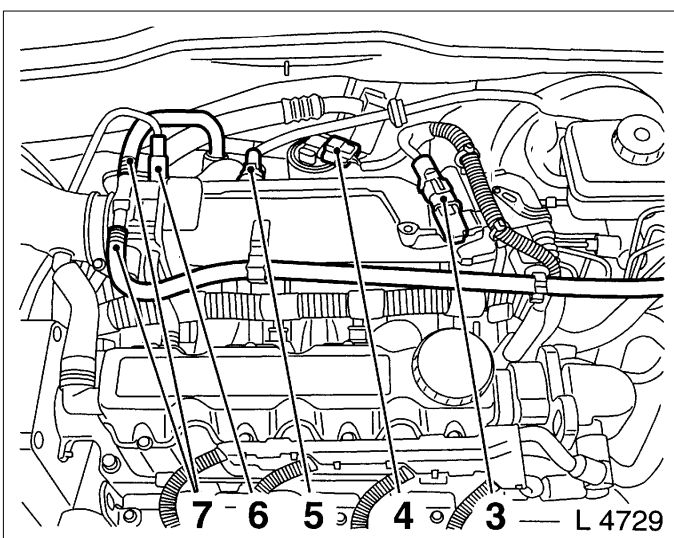

Removal Procedure

9. Remove ground cable (2) from engine control unit.
10. Disconnect wiring harness plug (4) from oxygen sensor, (5) throttle body, (7) camshaft sensor and injectors.
11. Detach wiring harness bracket (1) from intake manifold and lay wiring harness aside.
12. Remove alternator support (3) from alternator and intake manifold. Release alternator from alternator shackle (6) and swing alternator rearward.
13. Detach coolant hose from intake manifold – place collecting basin underneath.
14. Detach fuel lines from fuel distributor pipe. Unclip fuel line from bracket and lay aside.
15. Remove intake manifold bolts.
16. Remove intake manifold, spacer, and gasket from cylinder head.

Clean

Clean sealing surfaces and remove gasket remnants.

Installation Procedure

1. Attach inlet manifold and spacer with new seal to cylinder head.
Tighten
Tightening torque 22 Nm / 16 lb. ft.
2. Attach fuel line to fuel distributor pipe and clip in bracket.
3. Attach coolant hose to intake manifold.
4. Attach alternator to alternator shackle.
Tighten
Tightening torque 20 Nm / 15 lb. ft.
5. Attach alternator support to alternator and intake manifold.
Tighten
Tightening torque 20 Nm / 15 lb. ft.
6. Route wiring harness and attach wiring harness bracket to intake manifold.
Tighten
Tightening torque 20 Nm / 15 lb. ft.
7. Connect wiring harness plug to injectors, camshaft sensor, throttle body and oxygen sensor.

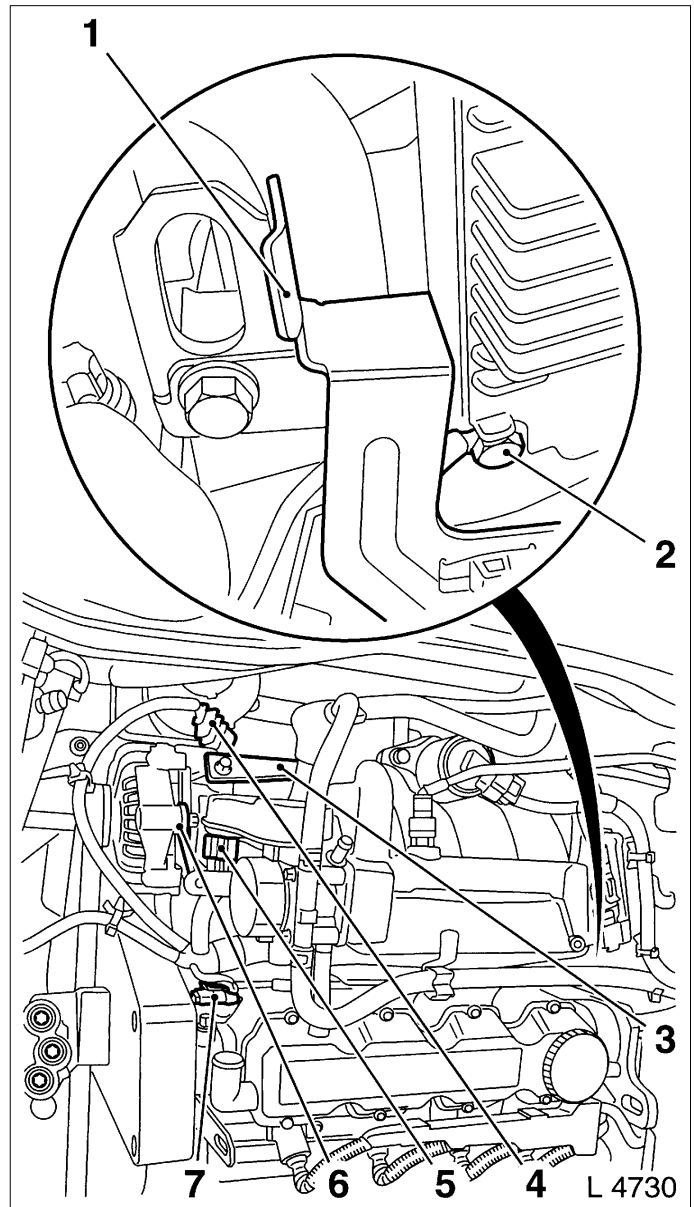

Installation Procedure

1. Attach coolant hoses to throttle body.
2. Install ribbed V-belt – see operation *Ribbed V-belt, Remove and Install*.
3. Attach engine vent hoses to camshaft housing cover.
4. Close coolant drain bolt.
5. Connect ground cable to battery.

Inspect

1. Top up cooling system – see operations *Cooling System, Top Up and Bleed* and *Cooling System, Check for Leaks*.

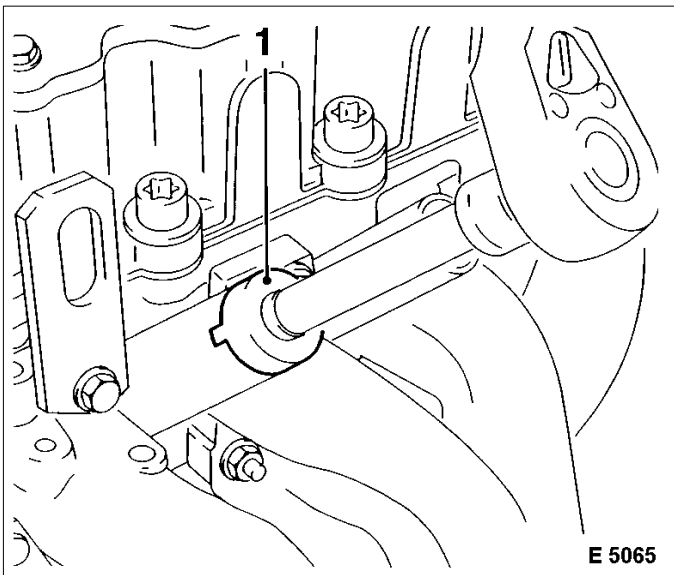

E 5065

Heat Shields, Remove and Install**Removal Procedure**

1. Remove fastening bolts for spark plug wiring trough.
2. Disconnect spark plug connectors and lay plug wires aside.
3. Remove heat shields from cylinder head with KM-834-A (1).

Installation Procedure

1. Coat heat shields with assembly paste (white) and install at cylinder head with KM-834-A.

Tighten

Tightening torque 25 Nm / 18 lb. ft.

2. Connect spark plug connectors.
3. Remove fastening bolts for ignition cable wiring trough.

Camshaft and Cam Follower, Remove and Install (Cylinder Head Installed)**Removal Procedure**

1. Remove upper part of toothed belt cover – see operation *Toothed Belt Cover – Upper Part, Remove and Install*.
2. Remove ribbed V-belts – see operation *Ribbed V-belts, Remove and Install*.
3. Remove lower part of toothed belt cover – see operation *Toothed Belt Cover – Lower Part, Remove and Install*.

Important: Before dismantling the toothed belt – screw fastening bolt for toothed belt drive gear into crankshaft and move crankshaft in engine rotational direction by 60° (dimension I) to before TDC mark.

Removal Procedure

1. Move toothed belt tension roller upward against spring force until bore holes align. Fix toothed belt tension roller in place with suitable drift (1).
2. Remove toothed belt from camshaft sprocket.
3. Remove camshaft sprocket – see operation *Seal Ring in Front Camshaft Housing, Replace*.
4. Remove DIS ignition module – see operation *DIS Ignition Module, Remove and Install*.
5. Remove carrier plate from camshaft housing – see operation *Seal Ring in Rear Camshaft Housing, Replace*.
6. Remove pressure plate (1) from camshaft housing.

Important: Cover oil return bore holes in cylinder head during assembly so thrust pieces cannot fall in.

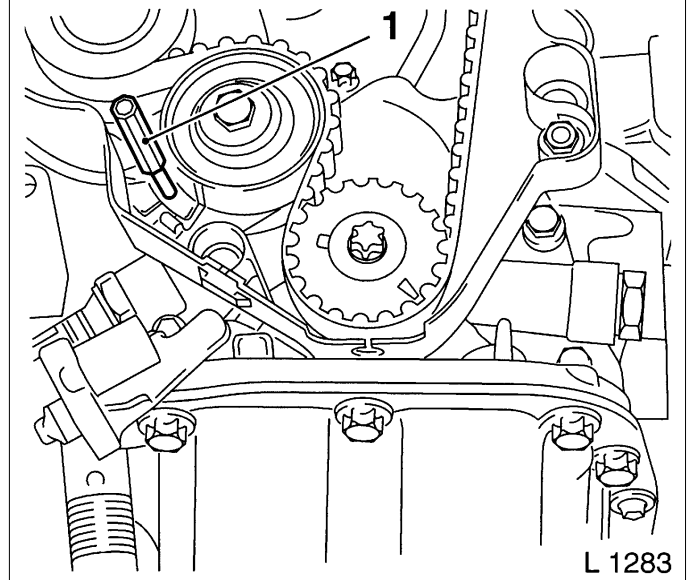
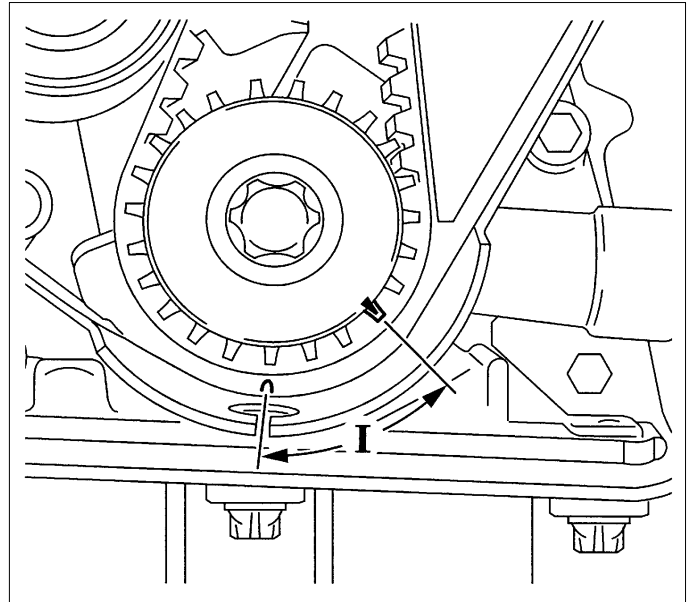

L 1283

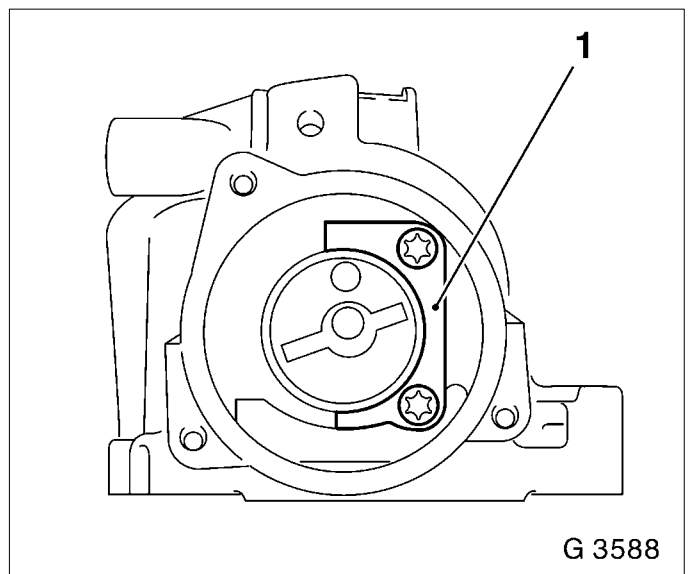

G 3588

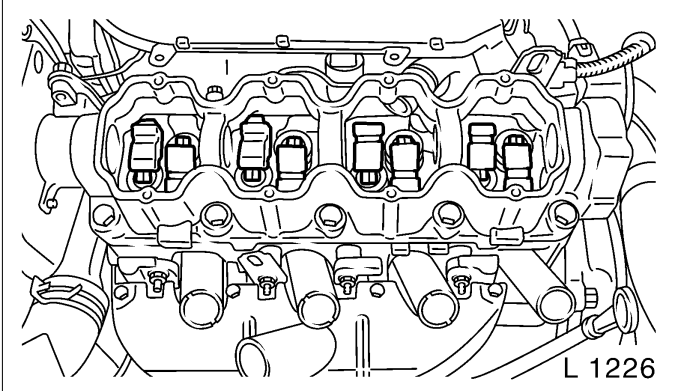
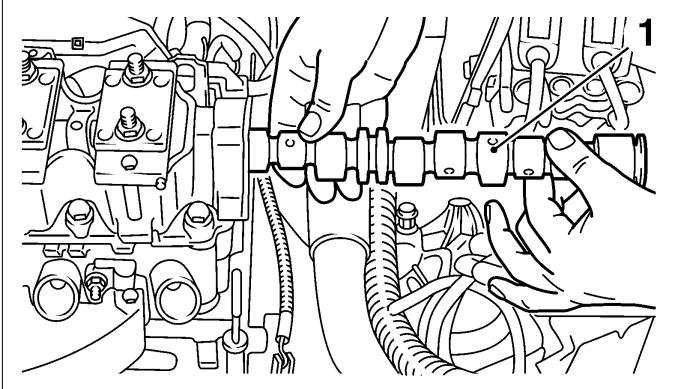
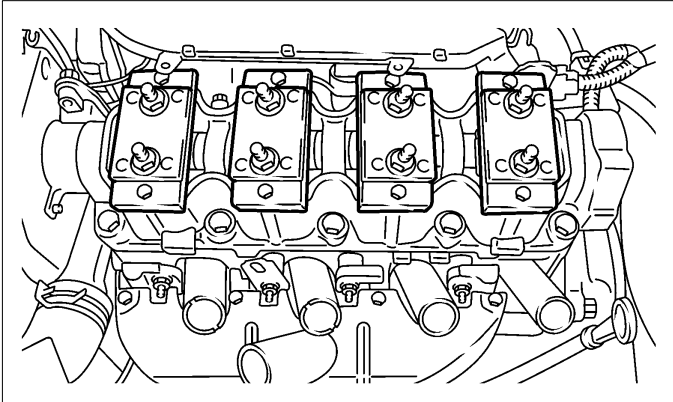

Removal Procedure

1. Attach Valve Lifter Depressor MKM-891 to camshaft housing.
2. Uniformly compress all cam followers.
3. Pull camshaft (1) out of camshaft housing.
4. Release valve lifter depressor and remove from camshaft housing.
5. Remove cam followers and thrust pieces – lay aside in installation position and note layout.

Inspect

1. Check all parts for damage and wear and replace if necessary. When replacing camshaft all cam followers must be replaced. Prior to installation ensure that crankshaft is 60° before TDC mark.

Installation Procedure

1. Insert thrust pieces and cam followers – note installation position and allocation.
2. Attach valve lifter depressor onto camshaft housing and press down all cam followers uniformly.
3. Coat sliding surfaces with MoS2 lubricating paste (grey).
4. Insert camshaft in camshaft housing.
5. Install pressure plate on camshaft housing.

Tighten

Tightening torque 8 Nm / 6 lb. ft.

Removal Procedure

1. Release tension in valve lifter depressor and remove from camshaft housing.

Installation Procedure

1. Attach carrier plate to camshaft housing – see operation *Seal Ring in Rear Camshaft Housing, Replace*.
2. Attach DIS ignition module – see operation *DIS Ignition Module, Remove and Install*.
3. Install camshaft sprocket – see operation *Seal Ring in Front Camshaft Housing, Replace*.

Important: Prior to installation of toothed belt, marks on toothed belt drive gear and oil pump housing, as well as notches on camshaft sprocket and rear toothed belt cover, must align – see operation Valve Timing, Adjust.

L 1226

Installation Procedure

1. Install toothed belt – see operation *Toothed Belt, Remove and Install*.
2. Remove fastening bolt from toothed belt drive gear and install toothed belt cover, lower part – see operation *Toothed Belt Cover, Lower Part, Remove and Install*.
3. Install ribbed V-belt – see operation *Ribbed V-belt, Remove and Install*.
4. Install upper part of toothed belt cover – see operation *Toothed Belt Cover – Upper Part, Remove and Install*.

Hydraulic Valve Lifter, Replace (Cylinder Head Installed)**Removal Procedure**

1. Detach engine vent hose from camshaft housing cover.
2. Detach wiring trough from camshaft housing cover.
3. Remove camshaft housing cover from camshaft housing.

Adjust

1. At fastening bolt of toothed belt drive gear, turn crankshaft in engine rotational direction until cam (1) of hydraulic valve lifter to be replaced assumes a vertical position.

Removal Procedure

1. Place KM-565-A (2) on camshaft housing and valve head and tension valve spring. Remove cam follower (3) from camshaft housing – note thrust piece.
2. Remove hydraulic valve lifter from camshaft housing.

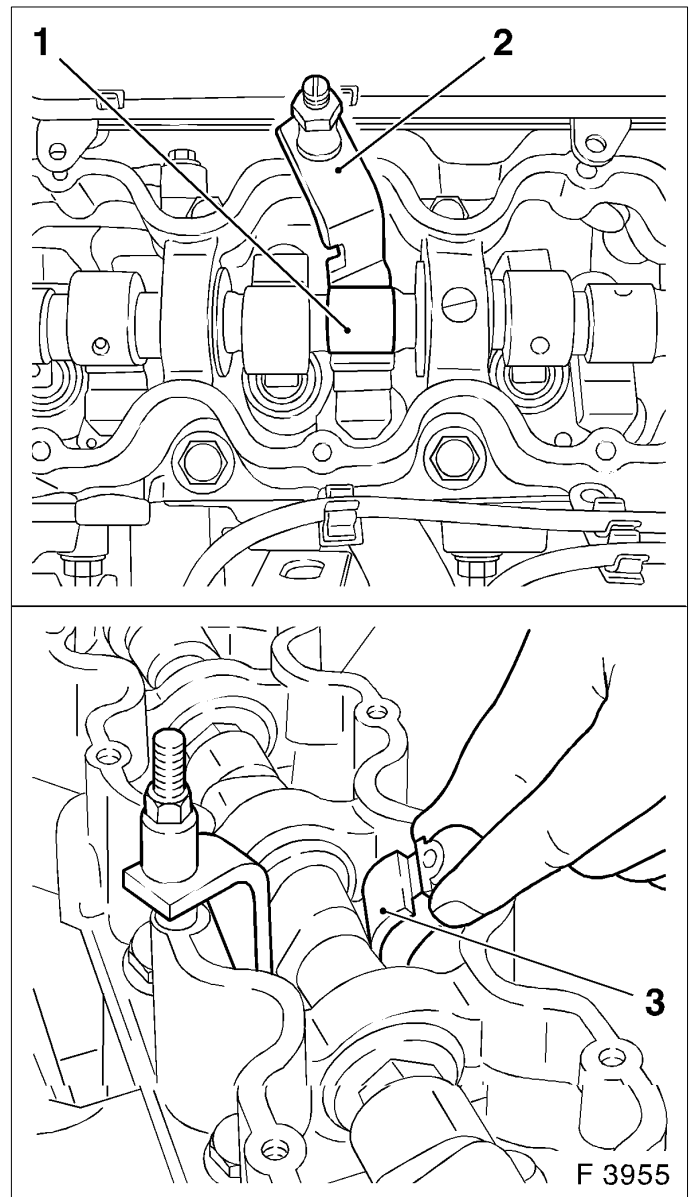

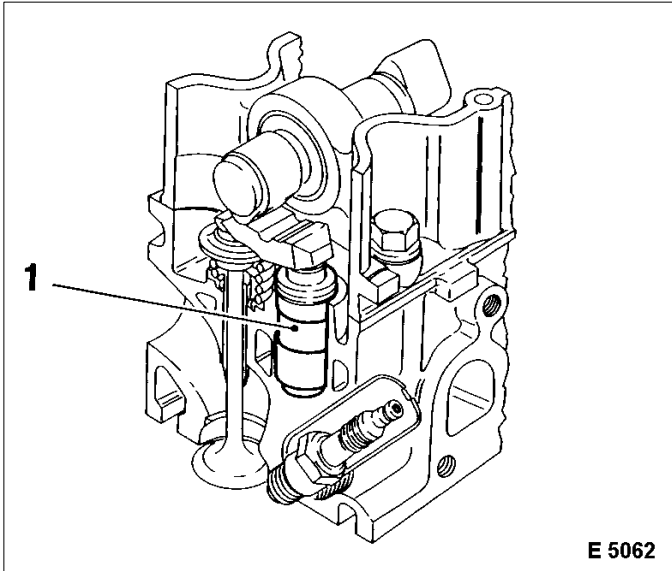

E 5062

Installation Procedure

1. Insert hydraulic valve lifter (1) in camshaft housing.
2. Coat sliding surfaces of the rocker arm with MoS2 lubricating paste (grey) and insert in camshaft housing – note thrust piece.

Adjust

1. Adjustment of the hydraulic valve lifter is no longer required, as pre-tensioning has been taken into account in design.

Installation Procedure

1. Release valve spring and remove KM-565-A.
2. Install camshaft housing cover at camshaft housing.

Tighten

Tightening torque 8 Nm / 6 lb. ft.

3. Attach wiring trough to camshaft housing cover.

Tighten

Tightening torque 8 Nm / 6 lb. ft.

4. Attach engine bleeding hose to camshaft housing cover.

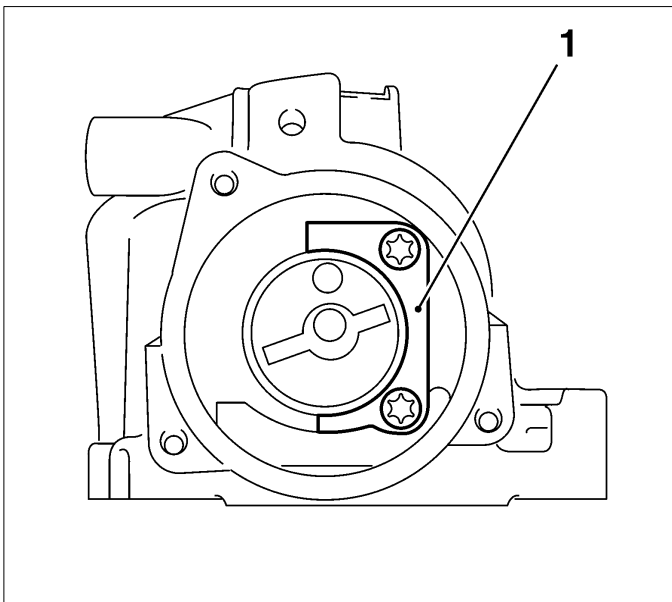
**Camshaft, Remove and Install (Cylinder Head Removed)****Removal Procedure**

1. Remove DIS ignition module – see operation *DIS Ignition Module, Remove and Install*.
2. Remove carrier plate from camshaft housing – see operation *Seal Ring in Rear Camshaft Housing, Replace*.
3. Remove pressure plate (1) from camshaft housing.
4. Remove camshaft from camshaft housing.
5. Edge front seal ring out of camshaft housing.

Clean

1. Clean sealing surfaces and remove gasket remnants.

Inspect

1. Check camshaft housing for damage and wear – see operation *Camshaft Housing for Plane Surface, Check*. When replacing camshaft, always replace all cam followers.

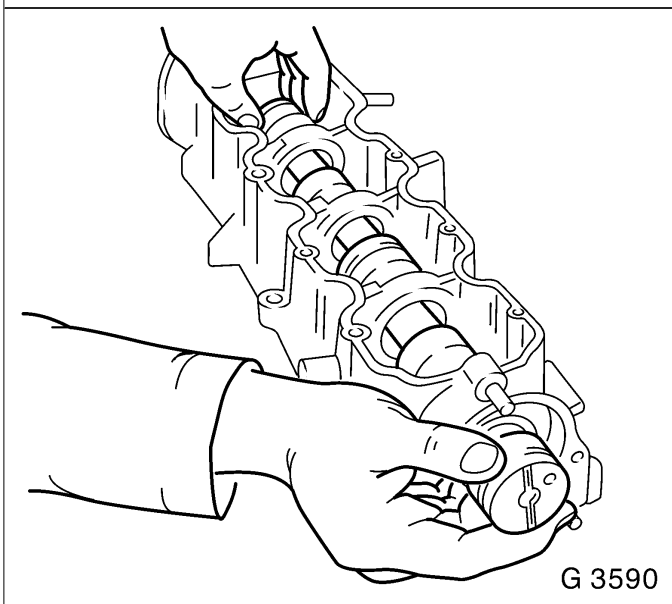

G 3590

Installation Procedure

1. Coat sliding surfaces of the camshaft with MoS2 lubricating paste (grey), insert camshaft in camshaft housing.
2. Install pressure plate on camshaft housing.
Tighten
Tightening torque: 8 Nm / 6 lb. ft.
3. Lightly coat sealing lip of front seal ring with silicon grease (white). Install new front seal ring with KM-422 in camshaft housing – use bolt and washer of camshaft pulley.
4. Attach carrier plate to camshaft housing – see operation *Seal Ring in Rear Camshaft Housing, Replace*.
5. Attach DIS ignition module – see operation *DIS Ignition Module, Remove and Install*.

Camshaft Housing, Replace**Removal Procedure**

1. Remove upper part of toothed belt cover – see operation *Toothed Belt Cover – Upper Part, Remove and Install*.
2. Remove ribbed V-belts – see operation *Ribbed V-belts, Remove and Install*.
3. Remove lower part of toothed belt cover – see operation *Toothed Belt Cover – Lower Part, Remove and Install*.
4. Remove toothed belt – see operation *Toothed Belt, Remove and Install*.
5. Remove toothed belt tension roller – see operation *Toothed Belt Tension Roller, Remove and Install*.
6. Rear toothed belt cover – see operation *Toothed Belt Cover – Rear, Remove and Install*.
7. Detach or disconnect all wiring harness plugs, ground connections and hose connections from intake manifold see operation *Intake Manifold, Remove and Install*.

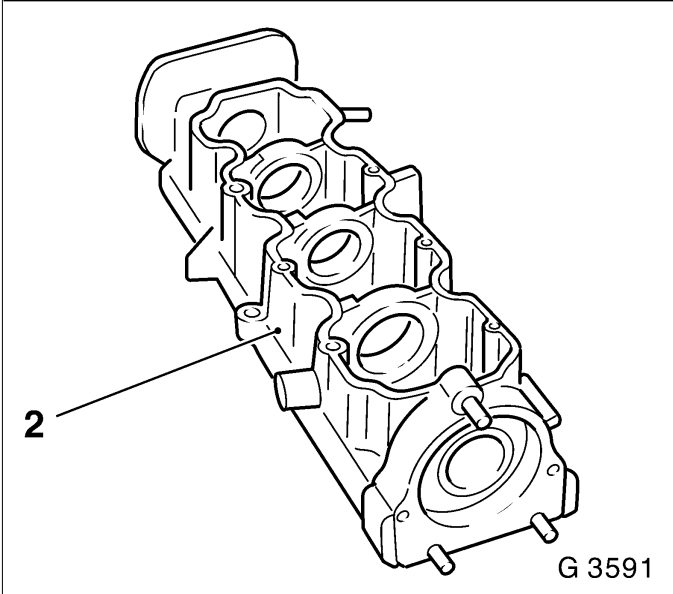
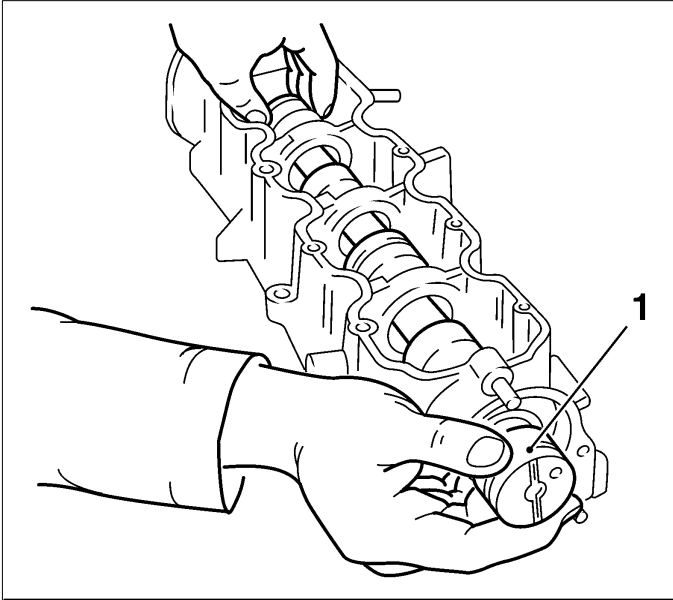

Removal Procedure

1. Remove cylinder head – see operation *Cylinder Head, Remove and Install*.
2. Remove DIS ignition module – see operation *DIS Ignition Module, Remove and Install*.
3. Remove carrier plate – see operation *Seal Ring in Rear Camshaft Housing, Replace*.
4. Remove camshaft (1) – see operation *Camshaft, Remove and Install (Cylinder Head Removed)*.

Clean

1. Clean sealing surfaces and bore holes and remove sealant residues.

Inspect

1. Check camshaft housing (2) for plane surface – see operation *Camshaft Housing for Plane Surface, Check*.

Installation Procedure

1. Install camshaft – see operation *Camshaft, Remove and Install (Cylinder Head Removed)*.
2. Install carrier plate – see operation *Seal Ring in Rear Camshaft Housing, Replace*.
3. Install DIS ignition module – see operation *DIS Ignition Module, Remove and Install*.
4. Install cylinder head – see operation *Cylinder Head, Remove and Install*.
5. Attach or connect all wiring harness plugs, ground connections and hose connections to intake manifold – see operation *Intake Manifold, Remove and Install*.
6. Install rear toothed belt cover – see operation *Toothed Belt Cover – Rear, Remove and Install*.
7. Install toothed belt tension roller – see operation *Toothed Belt Tension Roller, Remove and Install*.
8. Install toothed belt – see operation *Toothed Belt, Remove and Install*.
9. Install lower part of toothed belt cover – see operation *Toothed Belt Cover – Lower Part, Remove and Install*.
10. Install ribbed V-belt – see operation *Ribbed V-belt, Remove and Install*.
11. Install upper part of toothed belt cover – see operation *Toothed Belt Cover – Upper Part, Remove and Install*.

Camshaft Housing, Check for Plane Surface

Clean

1. Clean sealing surfaces and remove gasket remnants.

Inspect

1. Check sealing surfaces in length and width for deformation and check for warping along the diagonals – use straight edge. If deformed or warped, replace camshaft housing.

Measure

1. Height of camshaft housing (sealing surface to sealing surface).
Dimension I: 66.5 mm

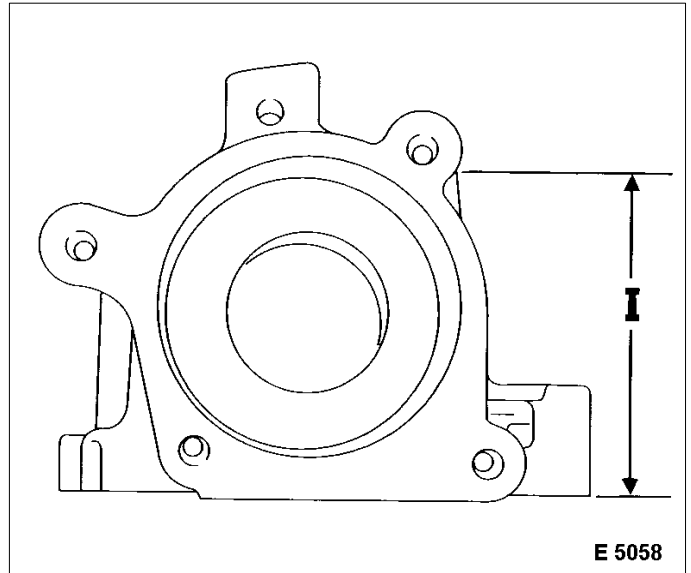

Cylinder Head, Remove and Install

Important: Remove cylinder head only with cold engine (room temperature).

Removal Procedure

1. Detach battery ground cable.
2. Open coolant drain bolt – collect escaping coolant.
3. Remove engine bleeding hose (1) from camshaft housing cover.
4. Remove upper part of toothed belt cover – see operation *Toothed Belt Cover – Upper Part, Remove and Install*.
5. Remove ribbed V-belts – see operation *Ribbed V-belts, Remove and Install*.
6. Detach alternator support (3) from alternator and intake manifold. Release alternator from alternator shackle (2) and swing alternator rearward.

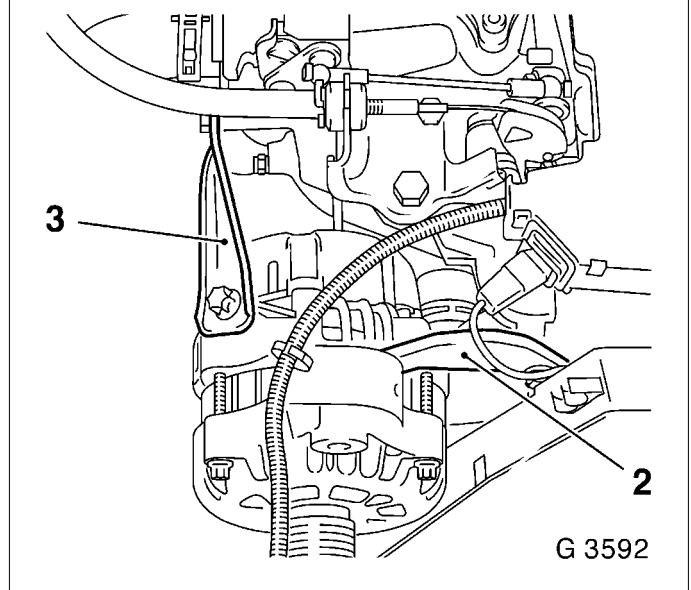
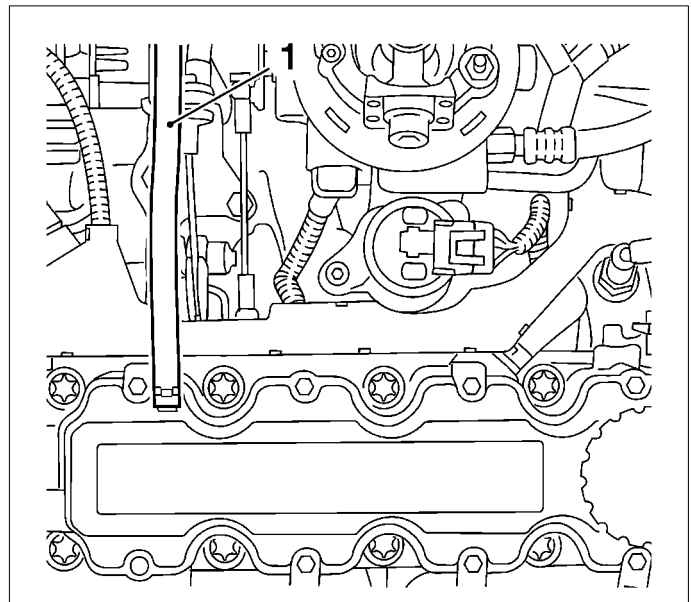

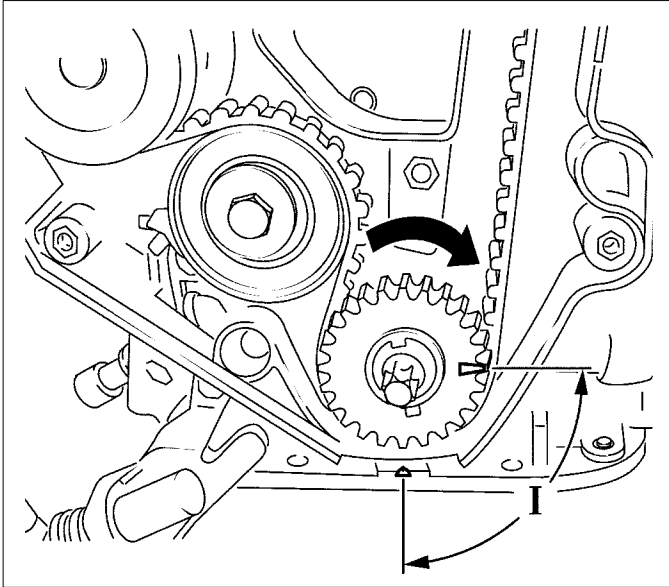

Removal Procedure

1. Remove lower part of toothed belt cover – see operation *Toothed Belt Cover – Lower Part, Remove and Install*.
2. Screw fastening bolt for toothed belt drive gear into crankshaft and move crankshaft in engine rotational direction by 90° (dimension I) to before TDC mark.
3. Detach or disconnect all wiring harness plugs, ground connections and hose connections from intake manifold – see operation *Intake Manifold, Remove and Install*.
4. Detach wiring harness plug (1) from DIS ignition module and expose wiring harness.
5. Detach wiring trough (2) from camshaft housing cover and lay aside.
6. Detach engine vent hose (3) from camshaft housing and engine vent flange and remove.
7. Remove coolant hose (6) from thermostat housing.
8. Detach ignition cable wiring trough from camshaft housing cover.
9. Disconnect spark plug connectors.

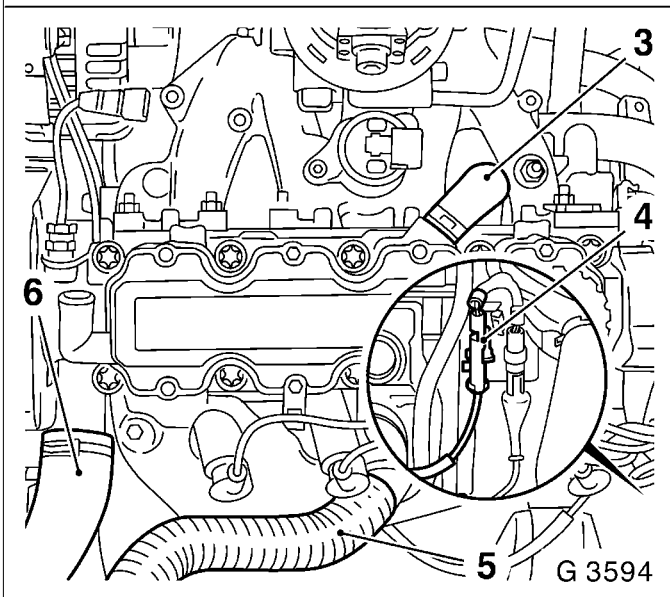
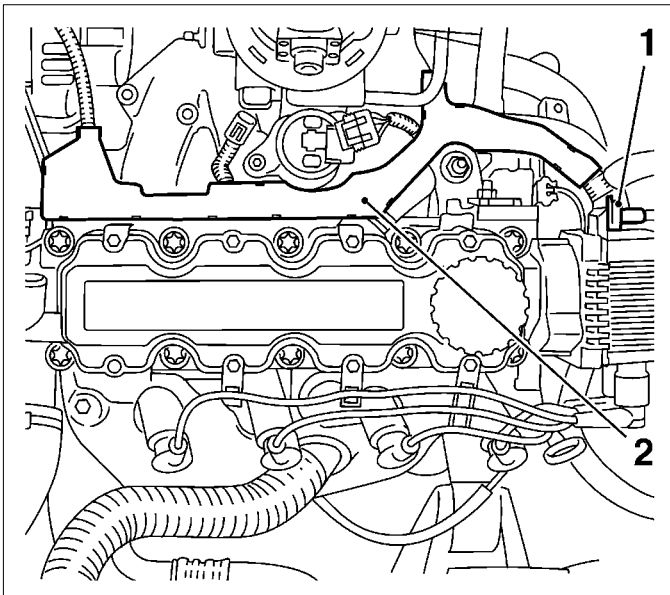

Removal Procedure

1. Move toothed belt tension roller upwards against spring force until bore holes align.
2. Fix toothed belt tension roller in place with suitable drift (2).
3. Mark running direction of the toothed belt for identification and remove toothed belt.
4. Remove toothed belt tension roller (4) from oil pump.
5. Remove toothed belt drive gear (3) from crankshaft.
6. Remove camshaft housing cover from camshaft housing.
7. Remove camshaft sprocket (1) – counterhold with open-ended spanner on hex of camshaft.

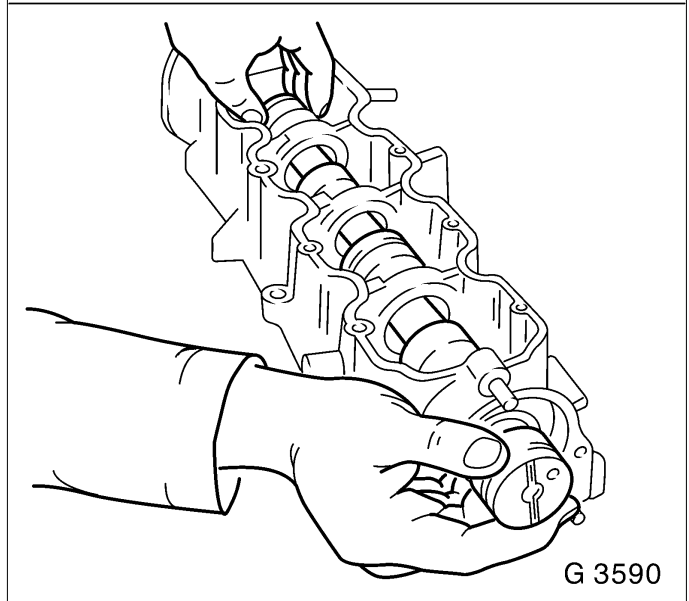
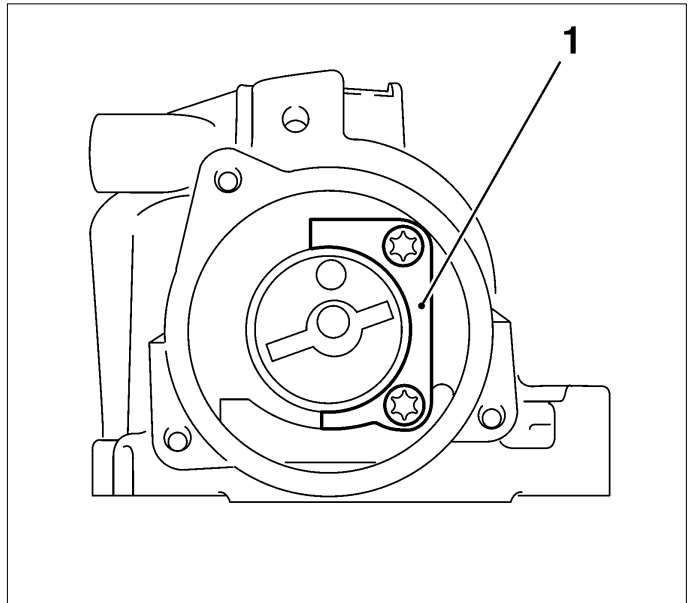
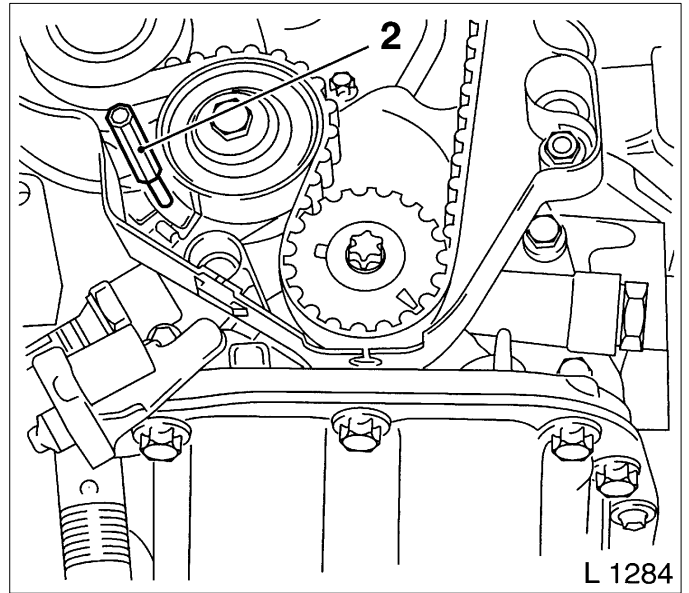

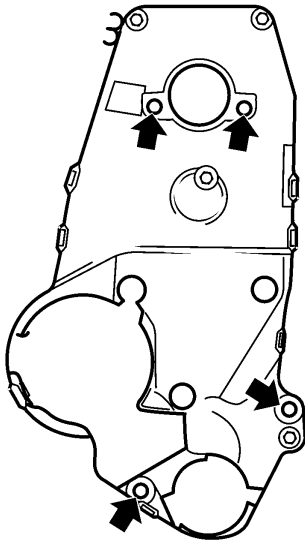
**Removal Procedure**

1. Remove rear part of toothed belt cover (arrow) from oil pump and camshaft housing.
2. Detach cylinder head bolts in sequence shown.
3. Remove camshaft housing from cylinder head.
4. Remove cam followers, thrust pieces and hydraulic valve lifter – note layout.
5. Remove cylinder head from cylinder block.

Clean

1. Clean sealing surfaces, bore holes and thread of cylinder head bolts.

Inspect

1. Check cylinder head and cylinder block for plane surface – see operations *Cylinder Head, Check for Plane Surface* and *Cylinder Block, Check for Plane Surface*.

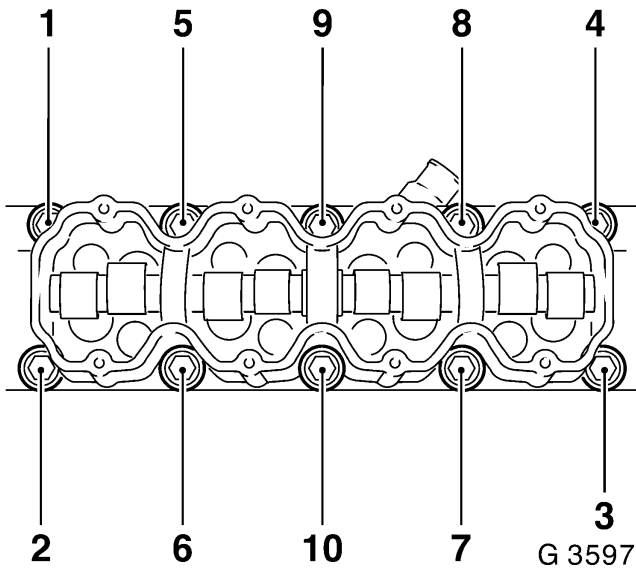

Installation Procedure

1. Install cylinder head gasket – mark "OBEN/TOP" on top and towards timing side of engine.
2. Place cylinder head on cylinder block.
3. Insert hydraulic valve lifters, thrust pieces and cam followers with MoS2 paste (grey) – note allocation.
4. Apply a bead of surface sealant (green) to sealing surfaces of cylinder head.

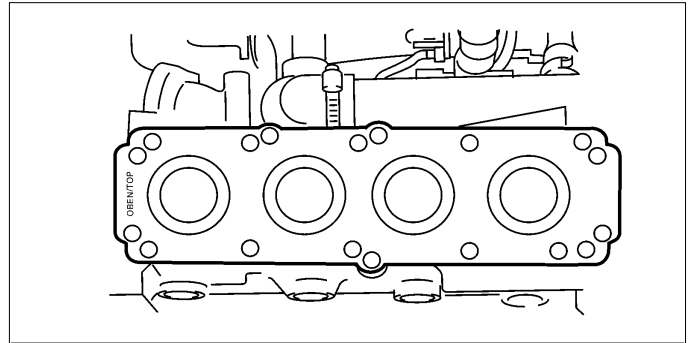

5. Place camshaft housing on cylinder head.
6. Tighten cylinder head bolts in order shown – use torque wrench and KM-470-B.
7. Attach cylinder head and camshaft housing with new cylinder head bolts to cylinder block.

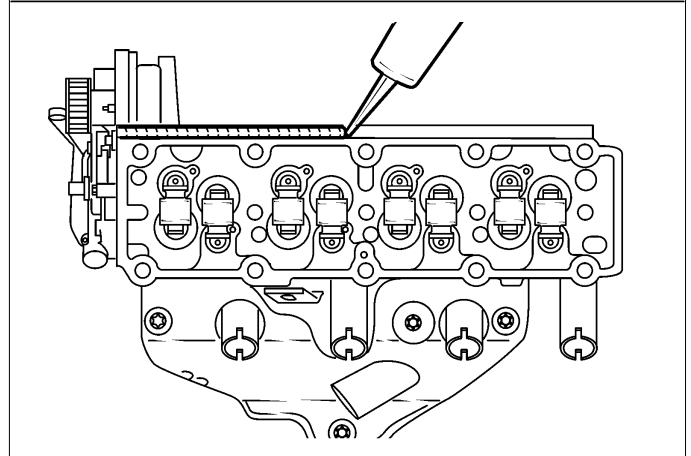

Tighten

Tightening torque 25 Nm / 18 lb. ft. + 60° + 60° + 60°.

8. Attach rear toothed belt cover to oil pump and camshaft housing.

Tighten

Tightening torque 6 Nm / 4 lb. ft.

9. Attach camshaft sprocket to camshaft – counterhold with open-ended spanner on hex of camshaft.

Tighten

Tightening torque 45 Nm / 33 lb. ft.

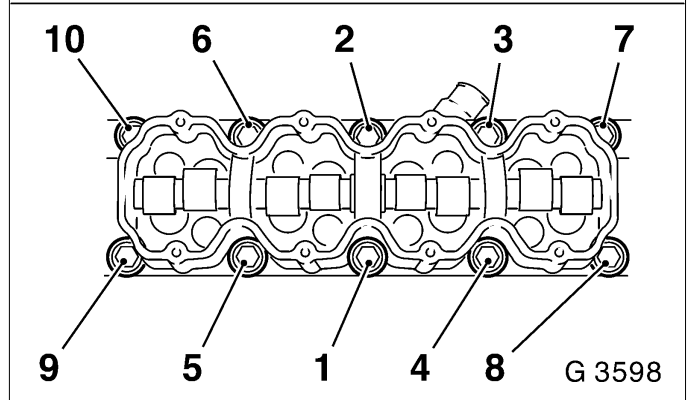

10. Install camshaft housing cover at camshaft housing.

Tighten

Tightening torque 8 Nm / 6 lb. ft.

11. Attach engine damping block support to cylinder block.

Tighten

Tightening torque 50 Nm / 37 lb. ft.

12. Slide toothed belt drive gear onto crankshaft journal – note installation position.

13. Attach toothed belt tension roller to oil pump.

Tighten

Tightening torque 20 Nm / 15 lb. ft.

14. Install toothed belt – ensure that tensioned side (I) is taut.

Notice: Note timing marks! – see operation *Valve Timing, Adjust.*

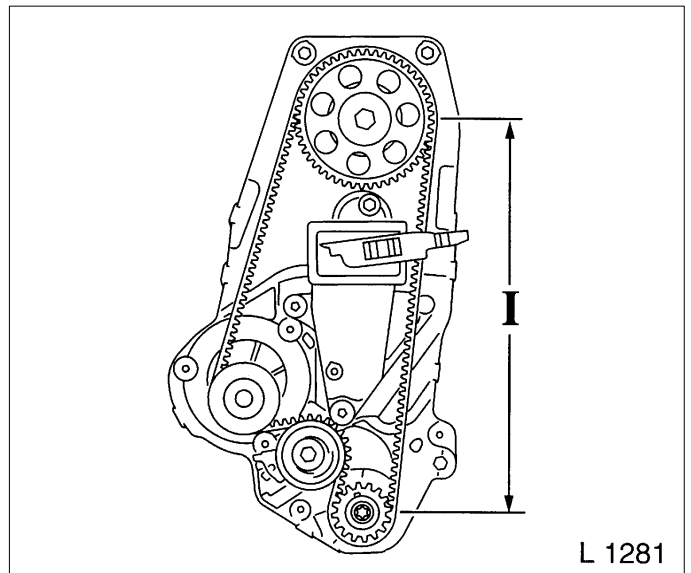

15. Adjust toothed belt tension – see operation *Toothed Belt Tension, Adjust.*

Installation Procedure

1. Install lower part of toothed belt cover – see operation *Toothed Belt Cover – Lower Part, Remove and Install*.
2. Attach ignition cable wiring trough to camshaft housing
Tighten
Tightening torque 8 Nm / 6 lb. ft.
3. Connect spark plug connectors to spark plugs.
4. Attach coolant hose to thermostat housing.
5. Attach engine vent hose to camshaft housing and engine vent flange.
6. Connect wiring harness plug to DIS ignition module – note cable routing.
7. Attach engine bleeding hose to camshaft housing cover.
8. Attach or connect all wiring harness plugs, ground connections and hose connections to intake manifold – see operation *Intake Manifold, Remove and Install*.
9. For version with hex bolts: Attach front exhaust pipe with new gasket and bolts coated with assembly paste (white) to exhaust manifold.
Tighten
Tightening torque 35 Nm / 26 lb. ft.
10. For version with hex nuts: Attach front exhaust pipe with new gasket and new nuts to exhaust manifold.
Tighten
Tightening torque 45 Nm / 33 lb. ft.
11. Close coolant drain bolt.
12. Attach alternator to alternator shackle.
Tighten
Tightening torque 20 Nm / 15 lb. ft.
13. Attach alternator support to alternator and intake manifold.
Tighten
Tightening torque 20 Nm / 15 lb. ft.
14. Install ribbed V-belt – see operation *Ribbed V-belt, Remove and Install*.
15. Install upper part of toothed belt cover – see operation *Toothed Belt Cover – Upper Part, Remove and Install*.
16. Connect ground cable to battery.

Inspect

1. Top up cooling system – see operations *Cooling System, Top Up and Bleed* and *Cooling System, Check for Leaks*.

Cylinder Head, Check for Plane Surface

Clean

1. Clean sealing surface and remove sealant remnants.

Inspect

1. Check length and width of cylinder head sealing surfaces for deformation and diagonals for warpage – use straight edge.

Important: Resurfacing of the cylinder head is not permitted.

Measure

1. Height of cylinder head (sealing surface to sealing surface)
Dimension I: 95.90 to 96.10 mm

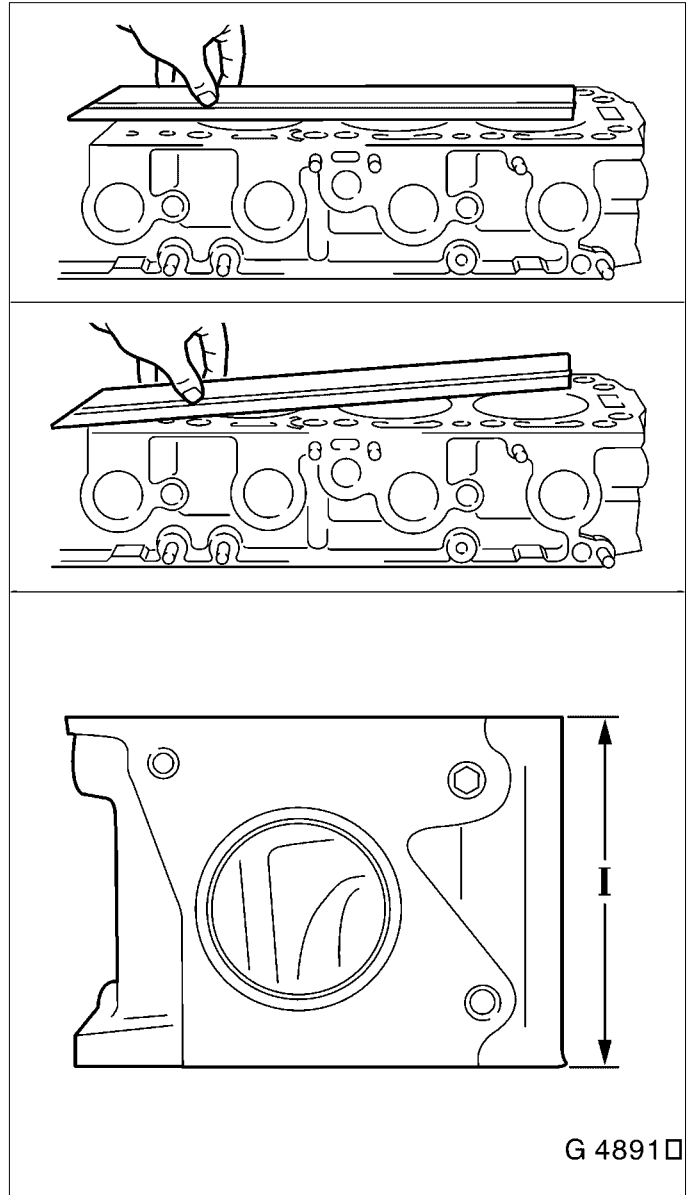

G 4891□

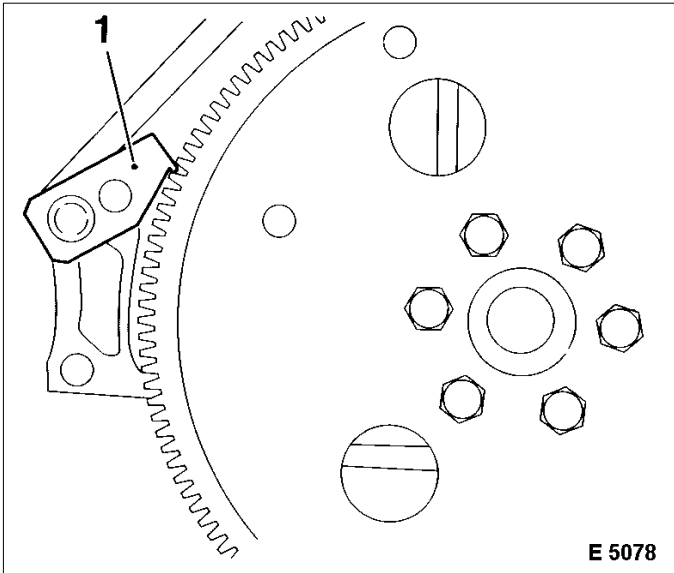

Crank Drive, Cylinder Block Drive Disc, Remove and Install

Removal Procedure

1. Counterhold drive disc with KM-652 (1) and remove from crankshaft.

Installation Procedure

1. Attach drive disc with new bolts to crankshaft. Counterhold drive disc with KM-652.

Tighten

Tightening torque 55 Nm / 41 lb. ft. + 30° + 15°.

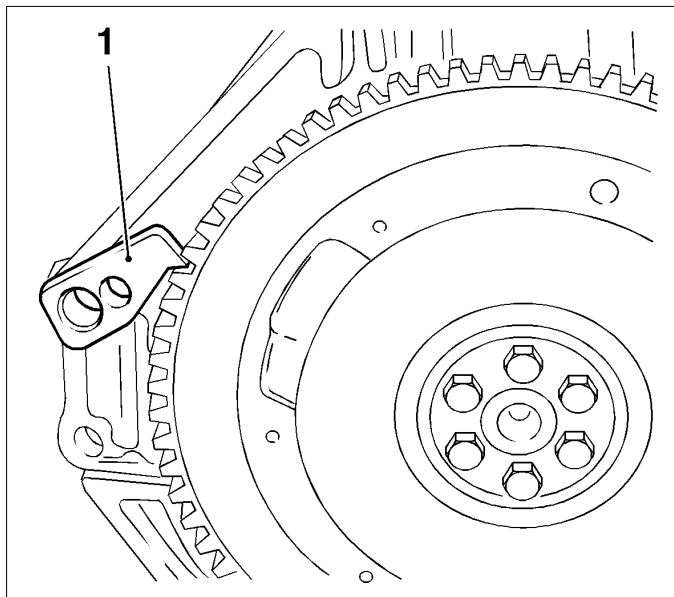

Flywheel, Remove and Install

Removal Procedure

1. Counterhold flywheel with KM-652 (1) and remove from crankshaft.

Installation Procedure

1. Attach flywheel to crankshaft with new bolts. Lock flywheel with KM-652 (2).

Tighten

Tightening torque 35 Nm / 26 lb. ft. + 30° + 15°

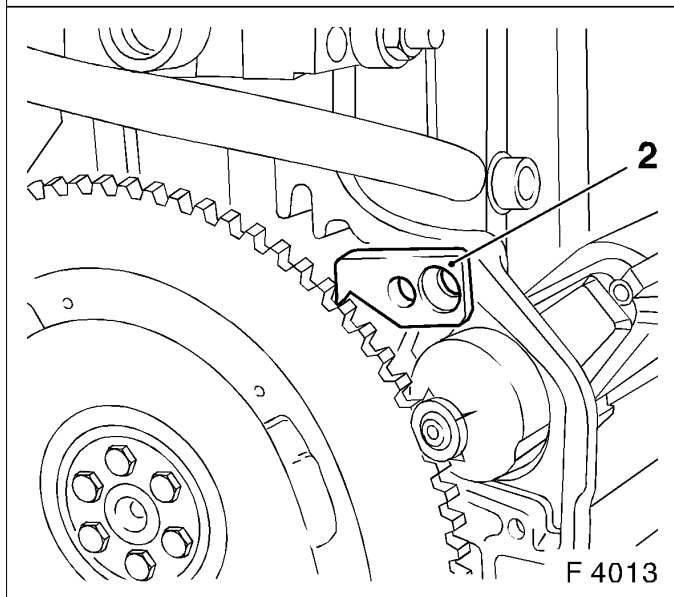

Seal Ring – Rear Crankshaft, Replace

Removal Procedure

1. Remove flywheel or drive disc – see operation *Flywheel, Remove and Install* or *Drive Disc, Remove and Install*.
2. Edge out seal ring (1) with suitable tool.

Important: Do not damage sealing surfaces.

Clean

1. Clean sealing surfaces and remove gasket remnants.

Installation Procedure

1. Coat sealing lip of new seal ring with silicon grease (white) and position with sealed side on Protective Sleeve KM-658-2 (2).
2. Connect protective sleeve with attached seal ring to crankshaft journal and press in flush. Place Installer Sleeve KM-658-1 (3) on Protective Sleeve KM-658-2 (2) and drive in seal ring until it sits flush in housing.
3. Install flywheel or drive disc – see operation *Flywheel, Remove and Install* or *Drive Disc, Remove and Install*.

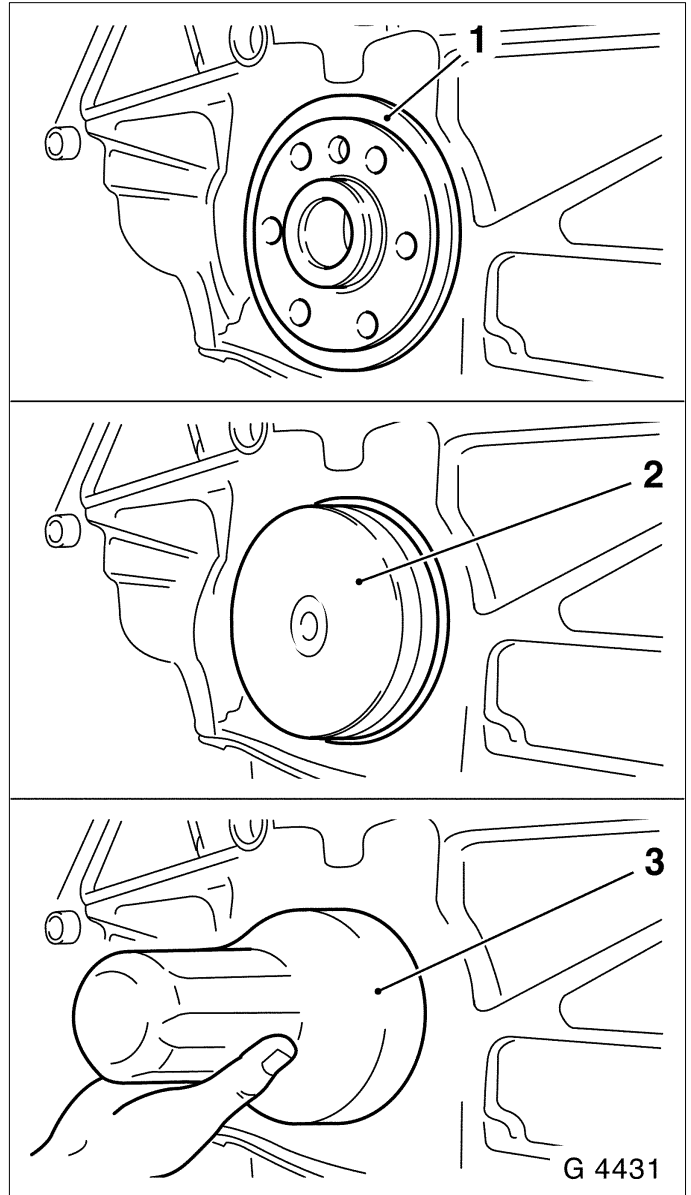

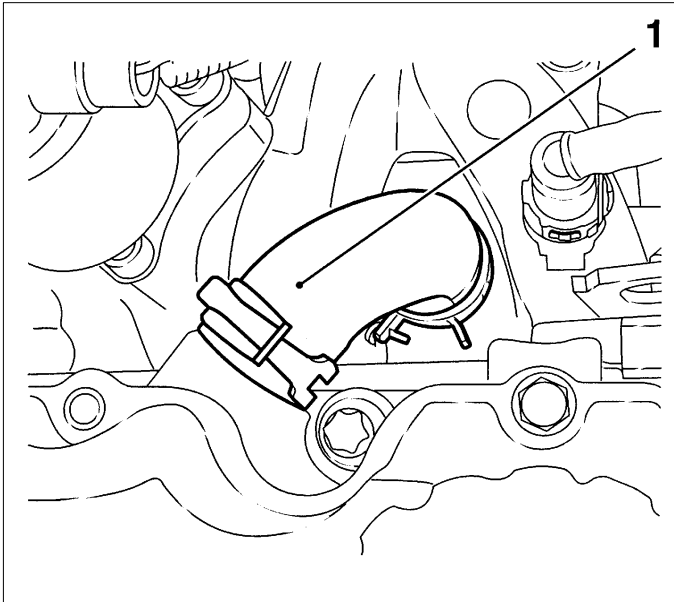

Engine Vent Flange and/or Gasket – Remove and Install

Removal Procedure

1. Remove engine vent hose (1) from camshaft housing and engine vent flange.
2. Detach engine vent flange (3) from cylinder block and remove downward with gasket.

Clean

1. Clean sealing surfaces.

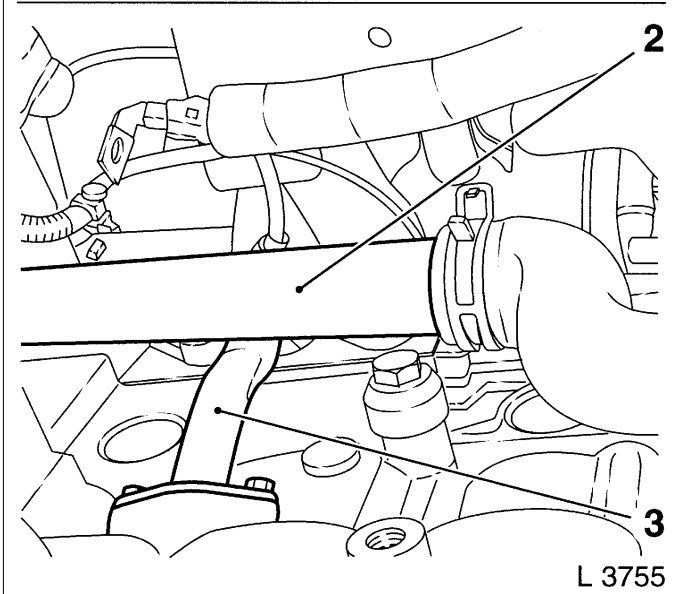

Installation Procedure

1. Insert new seal (2) – note installation position, bead (1) must point upwards to engine vent flange.
2. Attach engine vent flange to cylinder block –
Tighten
Tightening torque 8 Nm / 6 lb. ft.
3. Attach engine vent hose to engine vent flange and camshaft housing.

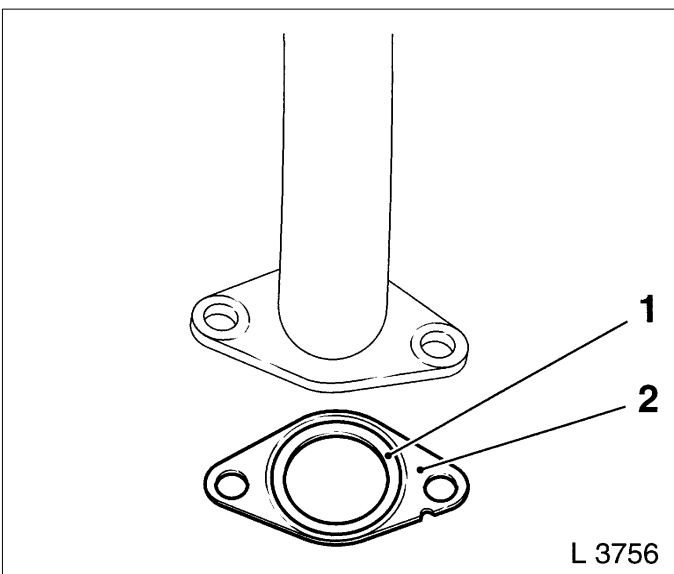

Piston with Con-rod, Remove and Install

Removal Procedure

1. Remove oil pan – see operation *Oil pan, Remove and Install*.
2. Remove cylinder head – see operation *Cylinder Head, Remove and Install*.
3. Remove oil intake tube (1) from oil pump and cylinder block.

Important: Mark order of con-rod bearing caps.

4. Remove con-rod bearing cap from con-rod.

Important: The mating surfaces of the con-rods and the con-rod bearing caps form an individual fit and as a result must not be damaged or replaced under any circumstances. Do not lay con-rods and con-rod bearing caps on mating surfaces in order to avoid damage.

5. Remove combustion residue from upper part of cylinder bore.
6. Push piston with con-rod upwards from cylinder bore using a block of wood or using a soft material to drive each piston out of the block.

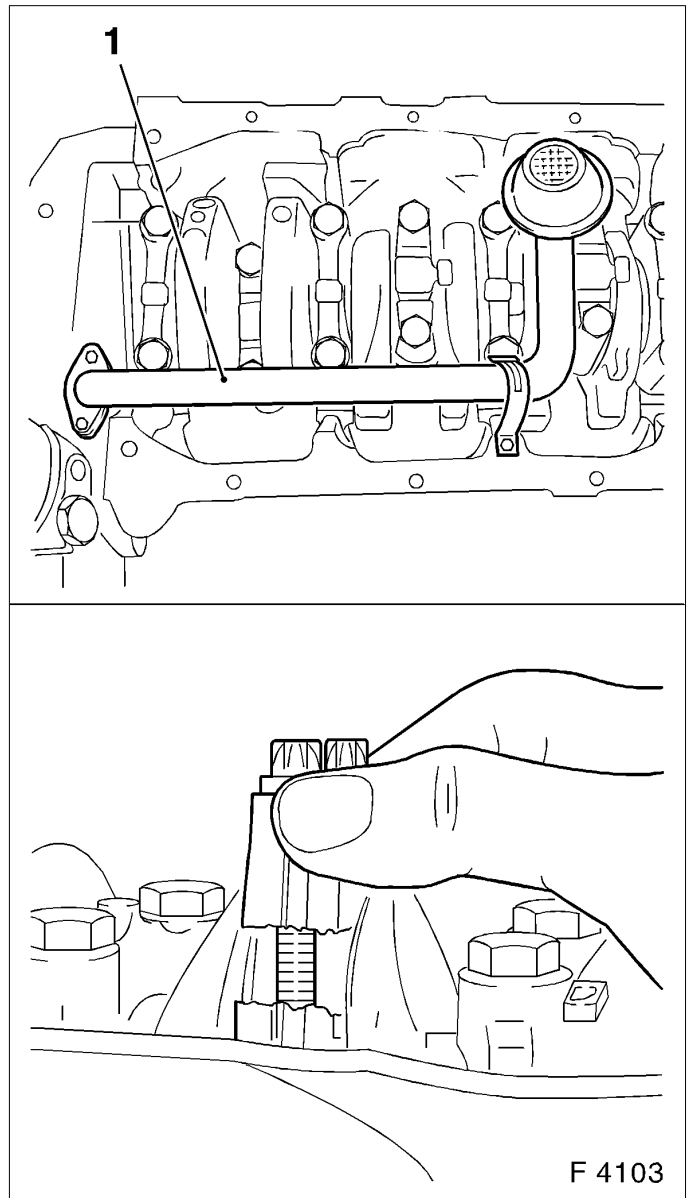

F 4103

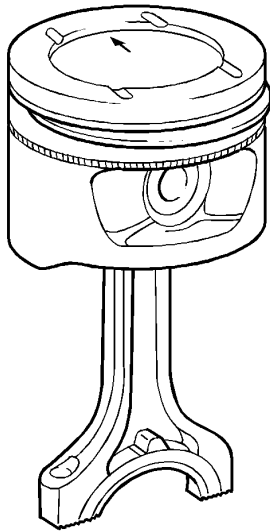

Important: Re-install the rod cap to the rod when the piston is removed from the engine block. The mating surfaces must be protected from damage.

Inspect

1. Check all parts, clean and if necessary, replace. Replace piston – see operation *Piston, Replace*.

Adjust

Before inserting con-rod journal of crankshaft, set to BDC position and coat with engine oil.

1. Adjust piston ring gaps:
 - Oil scraper ring II: offset ring gaps of the steel band rings each 25 to 50 mm to the left or right of gap in intermediate ring.
 - Piston rings I: offset ring gaps by approx. 120°. Second piston ring with identification "TOP" uppermost.

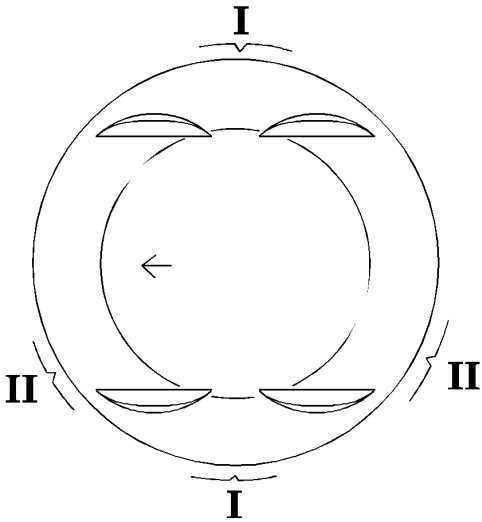

F 4104

Installation

1. Coat piston rings with engine oil and compress with piston ring pliers.
2. Push piston into cylinder bore with hammer shaft.

Important: Note installation position of piston and con-rod. Arrow (1) on piston head points to engine timing side, bead (2) on con-rod points to rear side of engine.

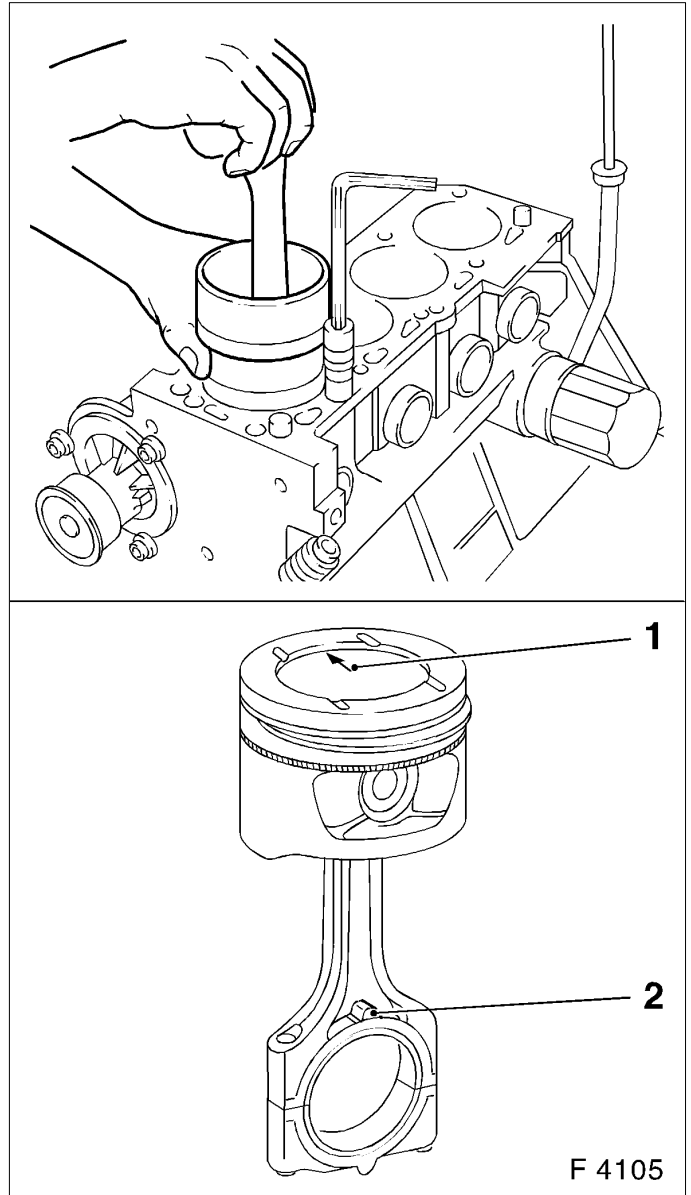

F 4105

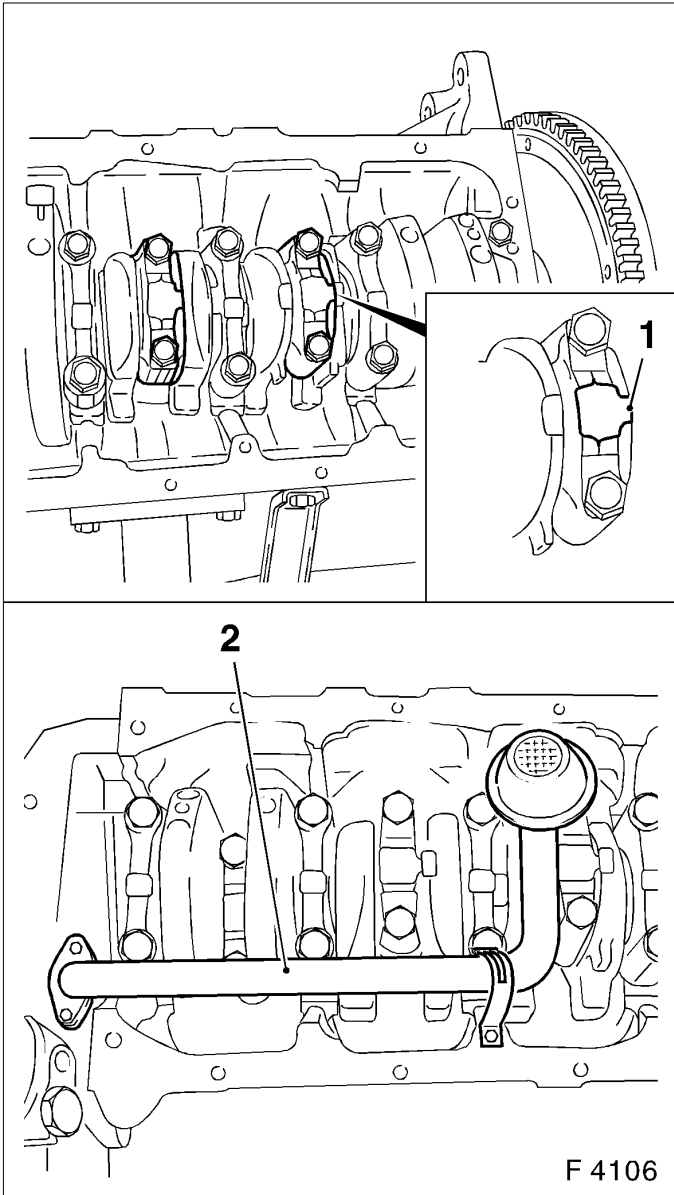

Installation Procedure

Note: Note sequence of con-rod bearing caps.

1. Install con-rod bearing cap – bead (1) of con-rod bearing caps points to flywheel side.
2. Attach con-rod bearing cap to con-rod with new bolts.
Torque
Tightening torque 25 Nm / 18.5 lb. ft. + 30°.
3. Attach oil intake pipe (2) with new seal ring to oil pump.
Torque
Tightening torque 8 Nm / 6 lb. ft.
4. Attach oil intake manifold to cylinder block.
Torque
Tightening torque 8 Nm / 6 lb. ft.
5. Install cylinder head – see operation *Cylinder Head, Remove and Install*.
6. Install oil pan – see operation *Oil Pan, Remove and Install*.

Important: Clean up or recut threads with proper die before reassembly and coat threads of new bolts with screw locking compound (red). The installation time including the torque check is max. 10 min.

Piston Rings, Remove and Install

Removal Procedure

1. Remove piston with con-rod – see operation *Piston with Con-rod, Remove and Install*.
2. Remove piston rings with piston ring pliers (1).

Clean

1. Clean piston ring grooves – use ground-down side of old piston ring.

Inspect

1. Check piston ring gap with feeler gauge by inserting piston ring at narrowest point of the cylinder bore.
Permissible ring gap:
Squared ring (2): 0.30 to 0.50 mm.
Tapered ring (3): 0.30 to 0.50 mm.
Oil scraper ring (4): 0.40 to 1.40 mm.

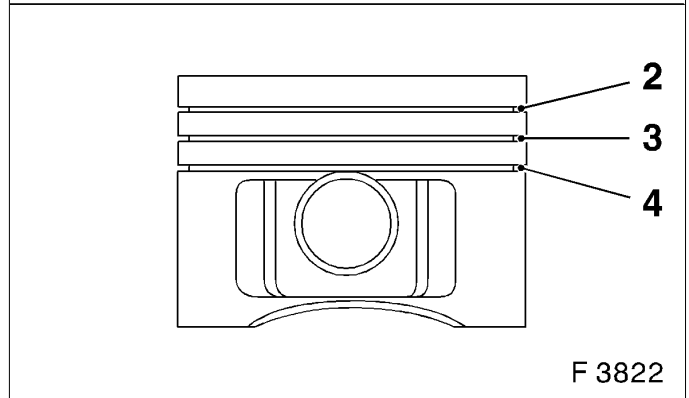
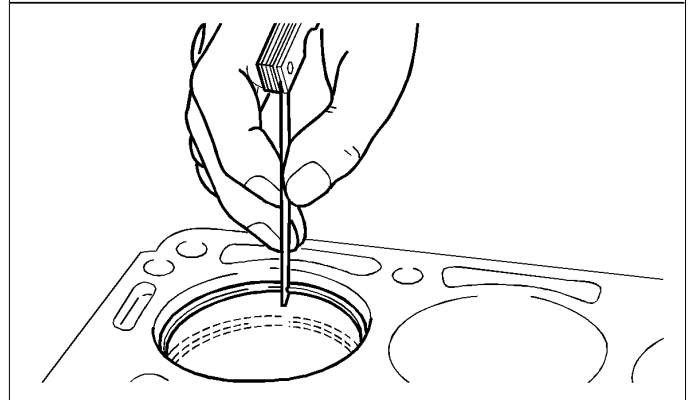
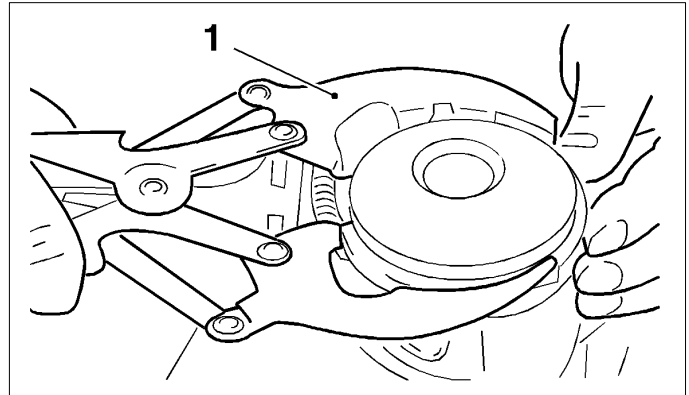

F 3822

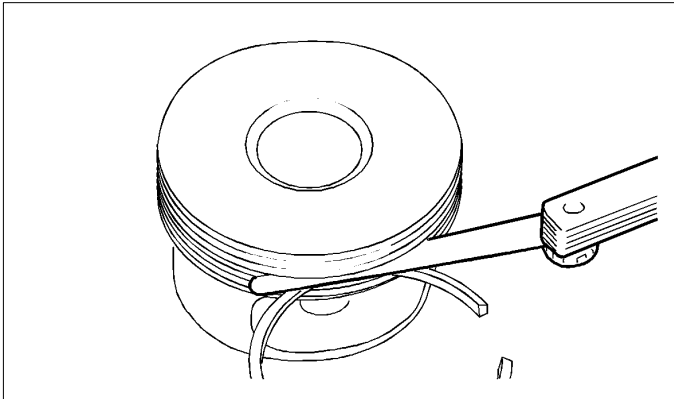
**Inspect**

1. Check piston ring vertical play with feeler gauge in piston ring groove.

Permissible vertical play:

Squared ring (1): 0.02 to 0.04 mm

Tapered ring (2): 0.04 to 0.06 mm

Oil scraper ring (3): 0.01 to 0.03 mm.

Installation Procedure

1. Insert piston rings with piston ring pliers and identification "TOP" upwards in piston.
2. Piston ring positioning – piston rings (I) (rectangular and tapered compression ring) offset 120°. Oil scraper rings (II) – offset 25 to 50 mm to left and from right of gap in intermediate ring.
3. Install piston with con-rod – see operation *Piston with Con-rod, Remove and Install*.

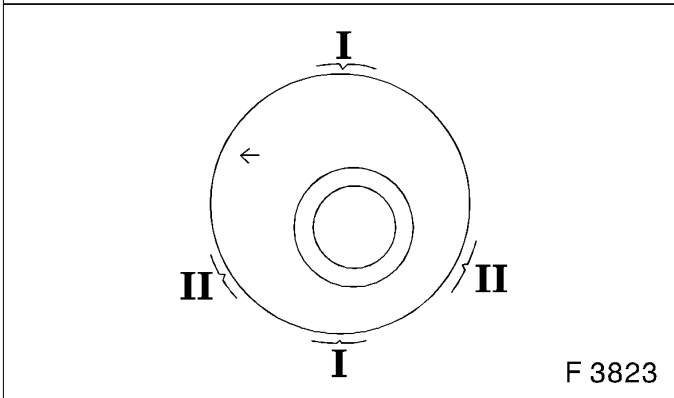
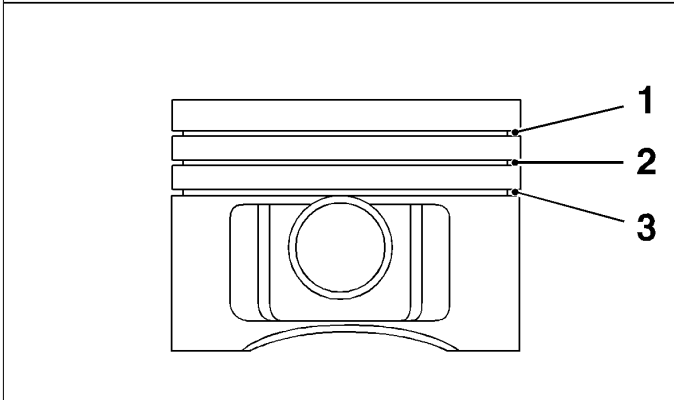

F 3823

Con-rod Bearing, Replace

Removal Procedure

1. Remove oil pan – see operation *Oil Pan, Remove and Install*.
2. Remove oil intake tube (1) from oil pump and cylinder block.

Important: Mark order of con-rod bearing caps.

3. Remove con-rod bearing cap from con-rod.

Important: The mating surfaces of the con-rods and the con-rod bearing caps form an individual fit and as a result must not be damaged or replaced under any circumstances. Do not lay con-rods and con-rod bearing caps on mating surfaces in order to avoid damage. Press con-rod bearing out of con-rod and con-rod bearing cap.

Clean

1. Con-rod bearing journals and con-rod bearing caps.

Installation Procedure

1. Insert new con-rod bearing shells with engine oil.

Important: Note sequence of con-rod bearing caps. Con-rod bearing caps – bead (1) of con-rod bearing caps points to flywheel side.

2. Attach con-rod bearing cap to con-rod with new bolts.

Tighten

Tightening torque 25 Nm / 18.5 lb. ft. + 30°.

3. Attach oil intake manifold to oil pump with new seal ring.

Tighten

Tightening torque 8 Nm / 6 lb. ft.

4. Attach oil intake manifold to cylinder block.

Tighten

Tightening torque 8 Nm / 6 lb. ft.

5. Apply a bead of adhesive sealing compound (black) to joints of oil pump and rear crankshaft bearing cap.

6. Install oil pan – see operation *Oil Pan, Remove and Install*.

Important: Clean up or recut threads with proper die before reassembly and coat threads of new bolts with screw locking compound (red). The installation time including the torque check is max. 10 min.

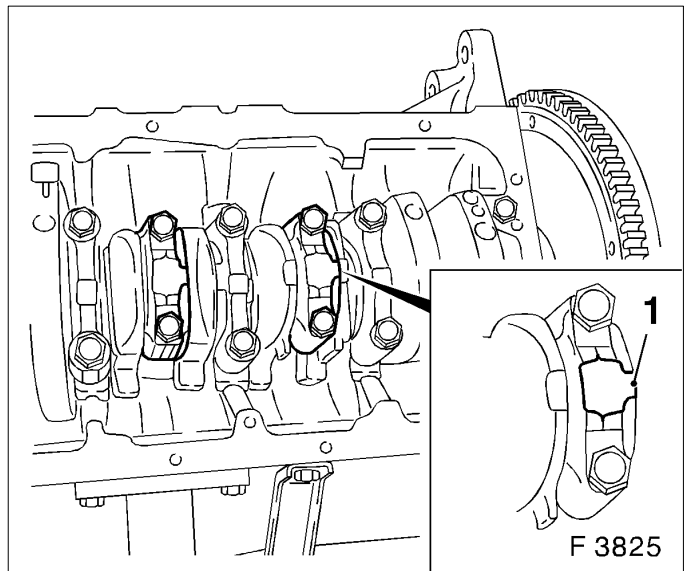
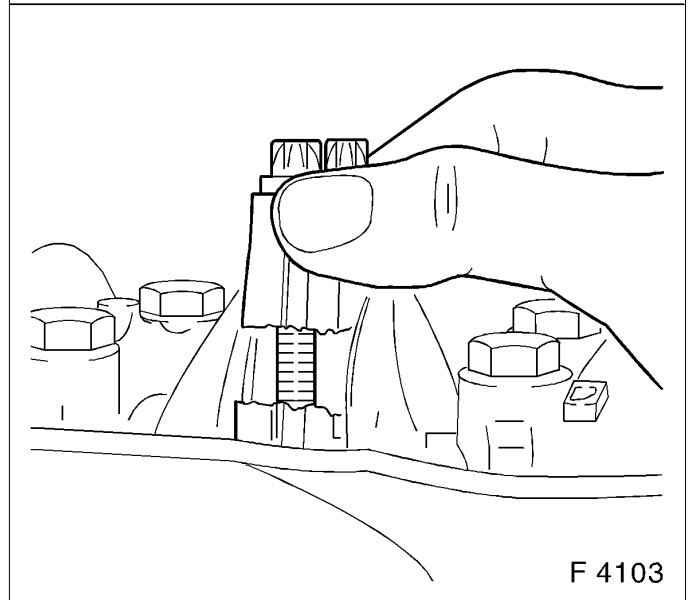
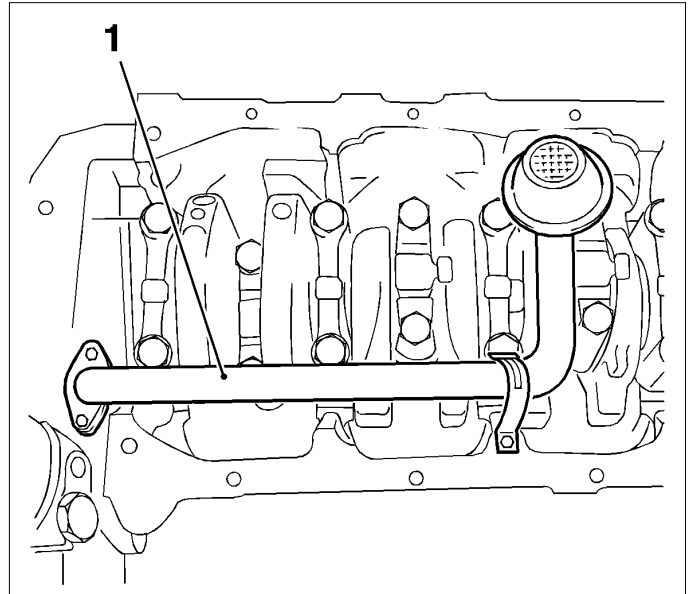

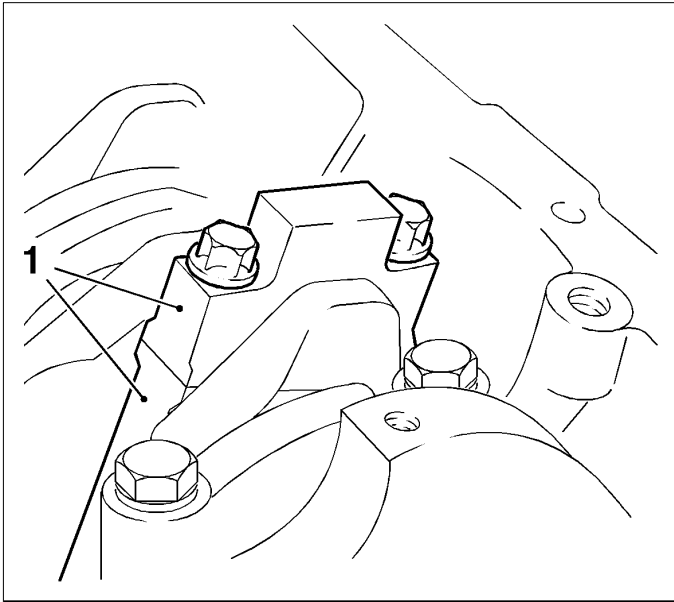

Con-rod Bearing Clearance, Check (Determine Bearing Clearance with Plastigage)

Removal Procedure

1. Mark installation position (1) of con-rod bearing cap – remove con-rod bearing cap from con-rod.

Important: To prevent the strip from tearing when removing the con-rod bearing cap, remove grease from the con-rod journal and lightly oil con-rod bearing shell. Do not turn the crankshaft.

Measure

1. Route Plastigage (malleable plastic strip) over the entire width of the con-rod bearing journal.

Torque-Angle Method

Con-rod bearing cap to con-rod.

Tighten

Tightening torque 25 Nm / 18 lb. ft. + 30°.

The bolts can be reused for checking the con-rod bearing clearance.

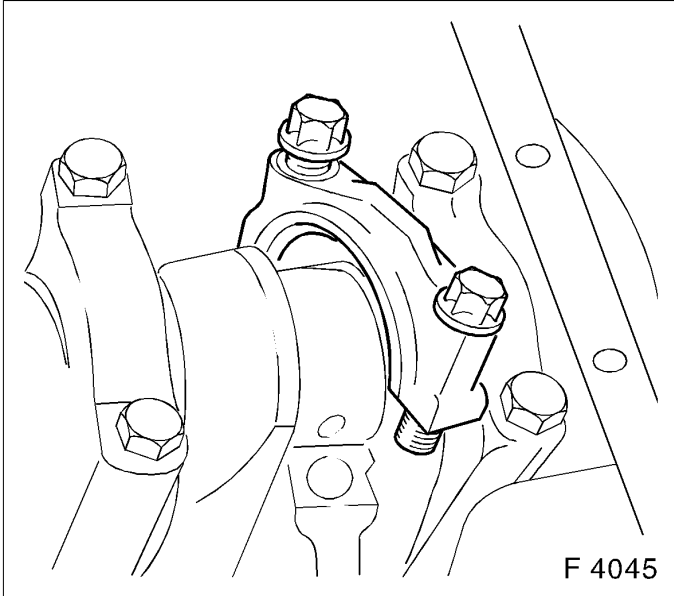

Measure

1. Remove con-rod bearing cap again. Compare width of flattened plastic thread (arrow) with measuring scale. Permissible con-rod bearing clearance: 0.019 to 0.071 mm.

Notice: When reading the value, do not confuse millimeters and inches on the measuring scale.

Installation Procedure

1. Clean con-rod bearing journal and con-rod bearing shell and lubricate lightly.
2. Con-rod bearing cap to con-rod – note installation position of the con-rod bearing cap.
3. Attach con-rod bearing cap to con-rod with new bolts.

Tighten

Tightening torque 25 Nm / 18.5 lb. ft. + 30°.

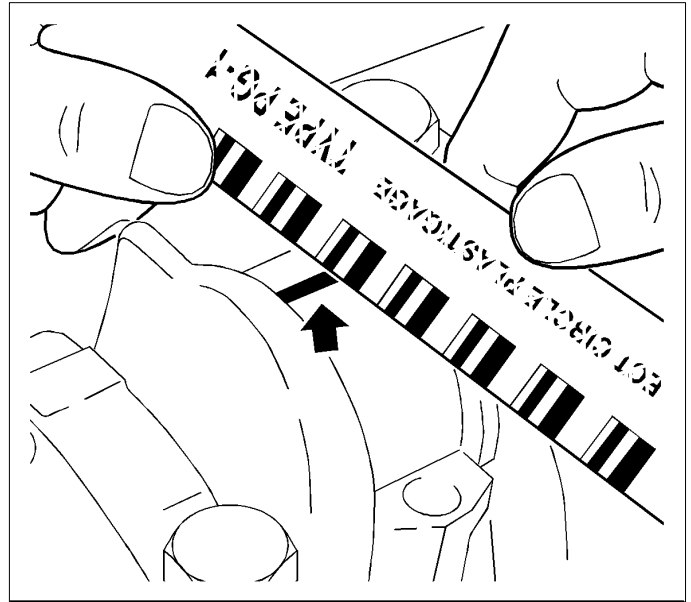

Con-rod Bearing Clearance, Check (Determine Bearing Clearance with Micrometer and Inside Micrometer)

Notice: Con-rod and crankshaft are removed.

Installation Procedure

1. Con-rod bearing cap with con-rod bearing shell to con-rod.

Tighten

Tightening torque 25 Nm / 18 lb. ft. + 30°.

The bolts can be reused for checking the con-rod bearing clearance.

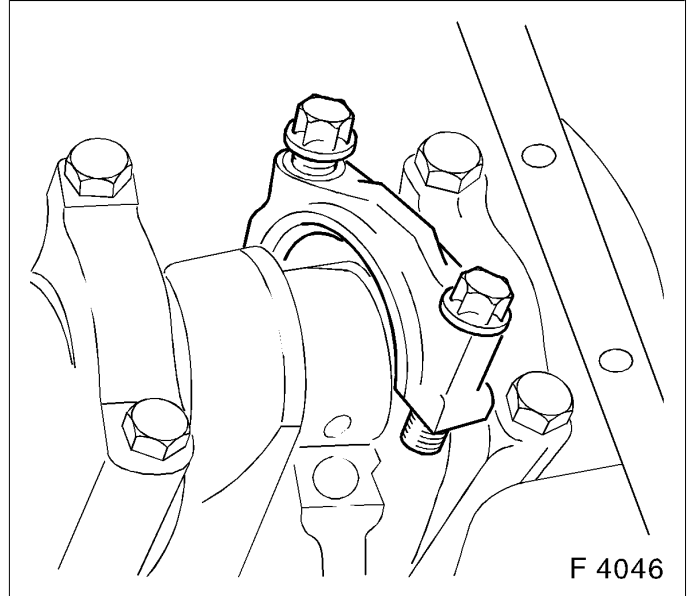

Formula for calculating the average con-rod bearing diameter:

$$\frac{I + II + III}{3}$$

Example:

I	42.738 mm
II	42.732 mm
III	+ 42.741 mm
	<u>128.211 mm / 3 = 42.737 mm</u>

The average con-rod bearing diameter is 42.737 mm.

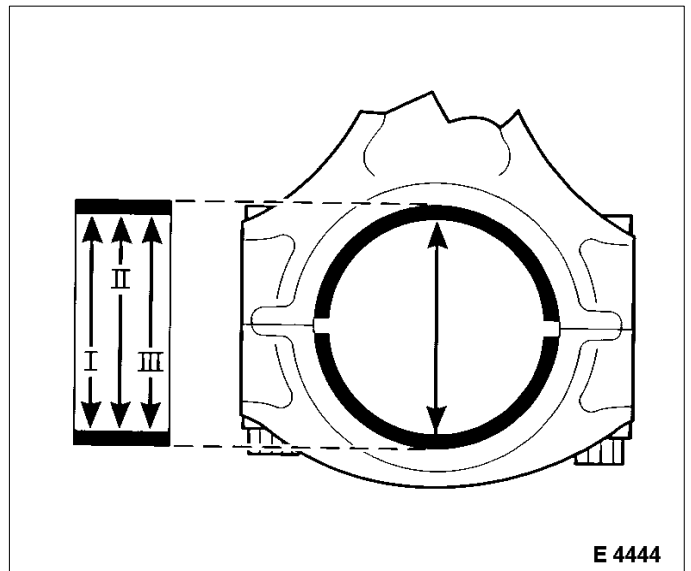

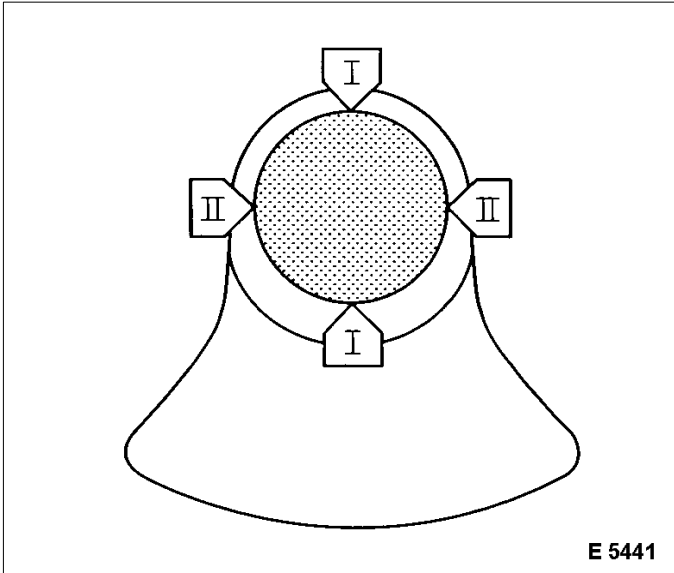

Measure

1. The con-rod bearing journal diameter is measured with a micrometer at points I and II and then calculated.

Formula for calculating the average con-rod bearing journal diameter: $\frac{I + II}{2}$

Example:

$$\begin{array}{r} I \quad \quad \quad 42.729 \text{ mm} \\ II \quad \quad \quad + \underline{42.725} \text{ mm} \\ \hline 85.454 \text{ mm} / 2 = 42.727 \text{ mm} \end{array}$$

The average con-rod bearing journal diameter is 42.727 mm.

The con-rod bearing clearance is calculated from the difference in diameter between the con-rod bearing bore and the con-rod bearing journal.

Example:

$$\begin{array}{r} \text{Avg. con-rod bearing dia.} \quad \quad \quad 42.737 \text{ mm} \\ \text{Avg. con-rod bearing journal dia.} \quad - \underline{42.727} \text{ mm} \\ \hline 0.010 \text{ mm} \end{array}$$

Permissible con-rod bearing clearance: 0.019 to 0.071 mm.

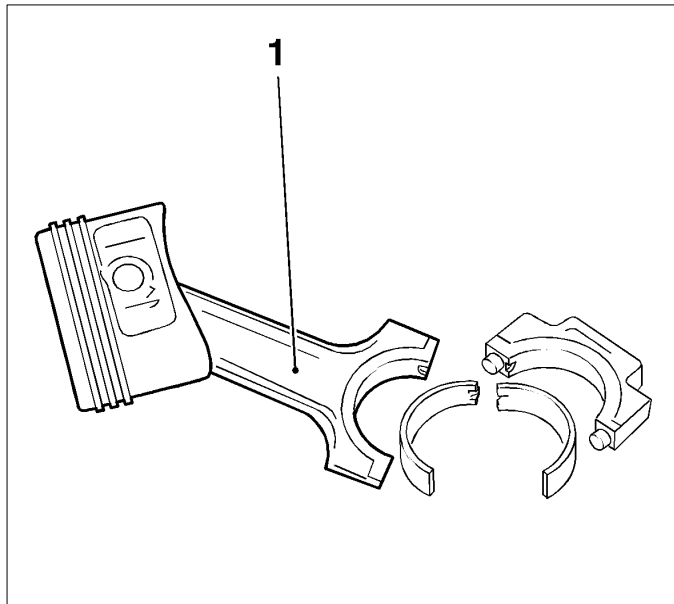

Piston, Replace

Notice: Removal of the piston pin is not permitted. If the piston, the piston pin or the con-rod is defective, all above-mentioned parts must be replaced.

Removal Procedure

1. Remove piston with con-rod (1) – see operation *Piston with Con-rod, Remove and Install*.

Installation Procedure

1. Coat con-rod eye and upper part of the con-rod shaft with thermocolor pencil. The green coloring turns black when the required assembly temperature is reached. The colored mark (arrow) is not permitted to discolor over the entire length, but only up to the start of the con-rod shaft. Heat new con-rod at upper con-rod eye with heater plate. Assembly temperature: 280 °C / 536 °F to max. 320 °C / 608 °F.

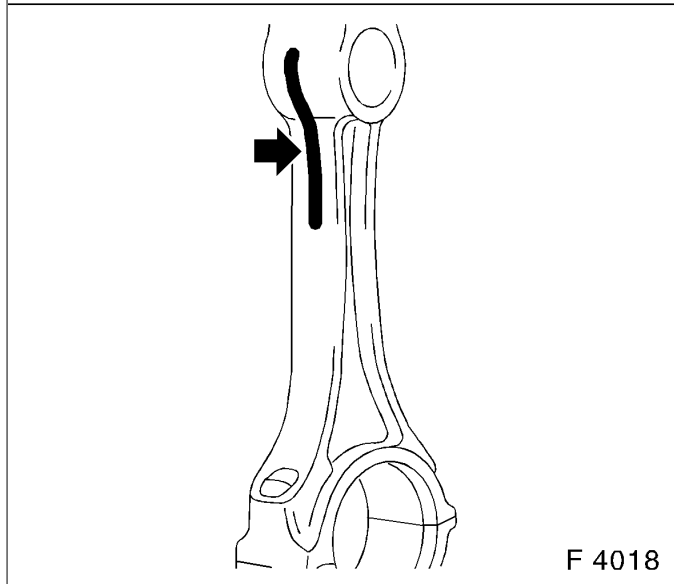

Important: Installation position: Bead (arrow) on con-rod points to flattened area (arrow) of the piston pin eye.

Notice: Firmly seated piston pin cannot be pressed further. Perform assembly quickly.

Assemble

1. Con-rod (1), piston pin, piston (2).
2. Slide new piston pin to stop in piston with guide drift.

Installation Procedure

1. Install piston with con-rod – see operation *Piston with Con-rod, Remove and Install*.

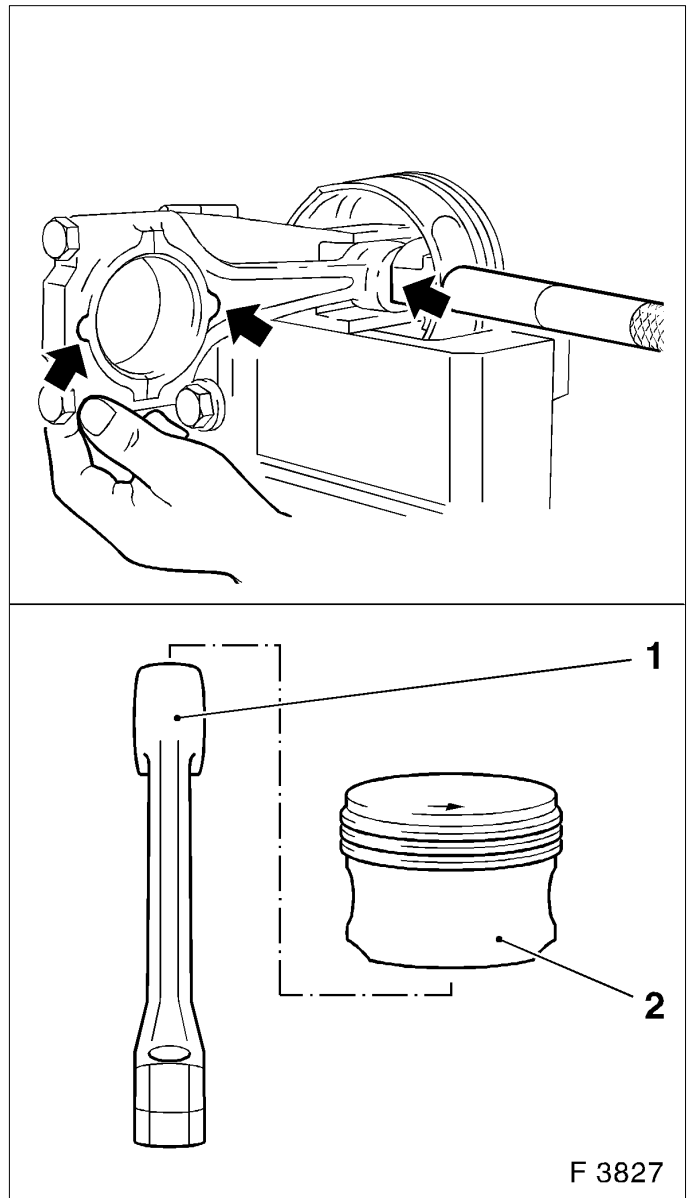

F 3827

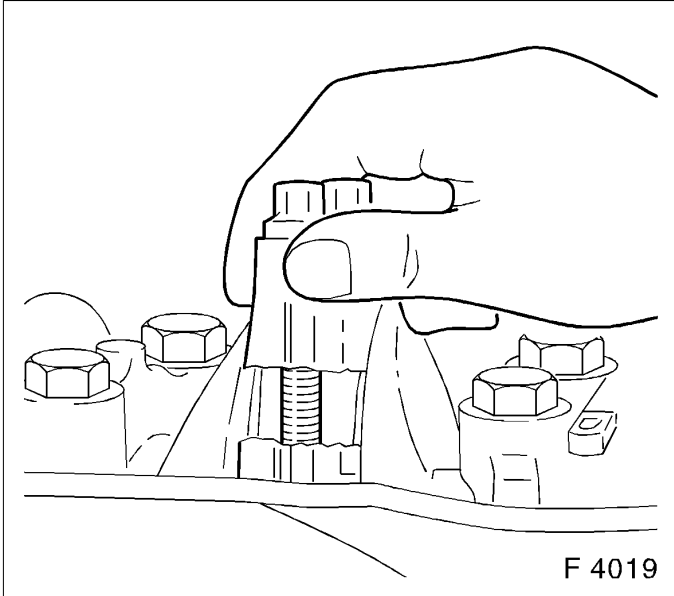
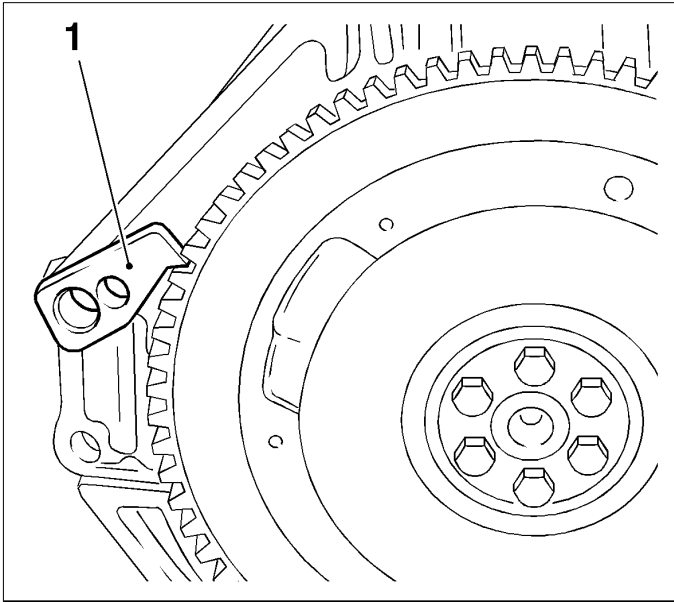

F 4019

Crankshaft, Remove and Install

Removal Procedure

1. Remove engine – see operation *Engine, Remove and Install*.
2. Mount engine with Adapter KM-412-10-A on Assembly Stands KM-412.
3. Remove oil pan – see operation *Oil Pan, Remove and Install*.
3. Remove oil pump – see operation *Oil Pump, Remove and Install*.
4. Lock flywheel or drive disc with KM-652 (1) and remove from crankshaft.

Important: Mark order of con-rod bearing caps. Remove con-rod bearing cap from conrod. The mating surfaces of the con-rods and the con-rod bearing caps form an individual fit and as a result must not be damaged or replaced under any circumstances. Do not lay con-rods and con-rod bearing caps on mating surfaces in order to avoid damage.

Removal Procedure

1. Identify sequence of crankshaft bearing caps.
2. Remove crankshaft bearing caps from cylinder block.
3. Remove crankshaft from cylinder block.

Clean

1. Clean all parts.

Inspect

1. Check crankshaft – see operation *Crankshaft, Check*.

Installation Procedure

1. Coat new bearing shells with engine oil and insert in cylinder block and bearing cap.
2. Insert crankshaft carefully in cylinder block. Seat of crankshaft can be corrected by lightly tapping on crankshaft webs (1) with rubber hammer.
3. Apply a bead of adhesive sealing compound (black) to grooves of rear crankshaft bearing cap. Install crankshaft and con-rod bearing cap.

Note marks and installation position.

4. Crankshaft bearing cap to cylinder block.

Tighten

Tightening Torque 50 Nm / 37 lb. ft + 45° +15°.

5. Con-rod bearing cap to con-rod.

Tighten

Tightening torque 25 Nm / 18.5lb. ft. + 30°

6. Install crankshaft rear seal ring – see operation *Seal Ring, Crankshaft, Rear Replace*.

7. Lock flywheel or drive disc with KM-652.

8. Install flywheel with new bolts to crankshaft.

Tighten

Tightening torque 35 Nm / 26 lb. ft. + 30° + 15°.

9. Install drive disc with new bolts to crankshaft.

Tighten

Tightening torque 55 Nm / 41 lb. ft. + 30° + 15°.

10. Install oil pump – see operation *Oil Pump, Remove and Install*.

11. Remove engine from Overhaul Stand KM-412 and remove Adapter KM-412-10 from engine. Install engine – see operation *Engine, Remove and Install*.

Important: Use new bolts. After assembly of bearing cap, press in adhesive sealing compound (black) from above again until adhesive sealing compound (black) escapes from the joints.

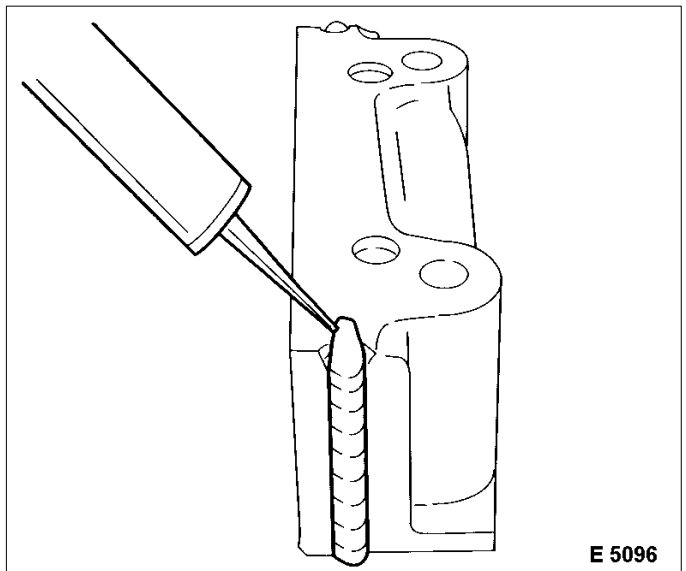
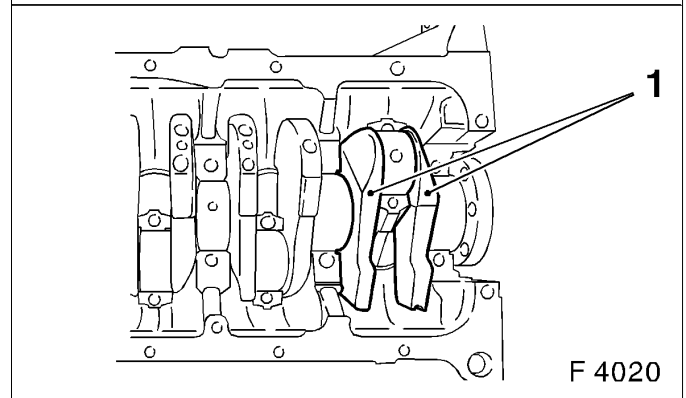
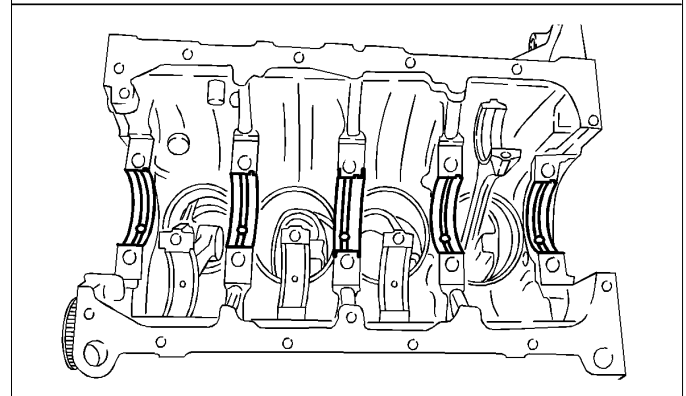
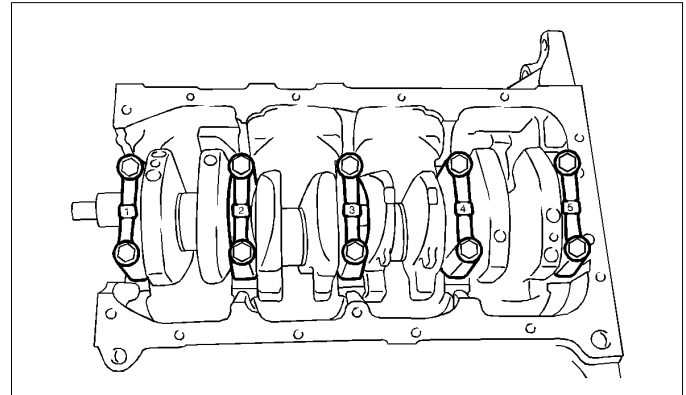

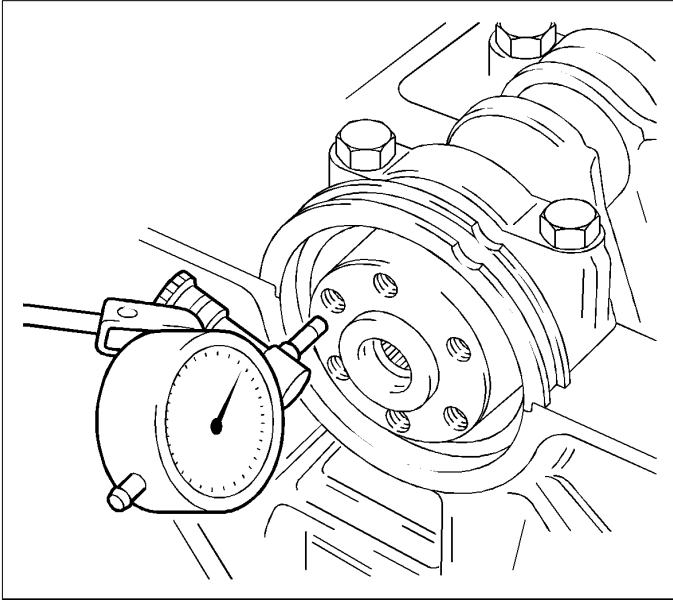

Crankshaft, Check

Crankshaft End Clearance, Check

Measure

1. Attach Dial Gauge MKM-571-B with dial gauge bracket to one face of cylinder block and position probe of dial gauge on crankshaft.
2. Slide crankshaft in longitudinal direction. Permissible crankshaft longitudinal play: 0.100 to 0.202 mm.

Crankshaft Out-of-round, Check

Inspect

1. Remove crankshaft bearing cap.
2. Attach Dial Gauge MKM-571-B with dial gauge bracket to cylinder block.
3. Apply probe of the Dial Gauge MKM-571-B to crankshaft bearing journal.
4. Turn crankshaft uniformly. Max. perm. out-of-round: 0.03 mm.
5. Crankshaft bearing cap with new bolts to cylinder block.

Tighten

Tightening torque 50 Nm / 37 lb. ft. + 45° + 15°.

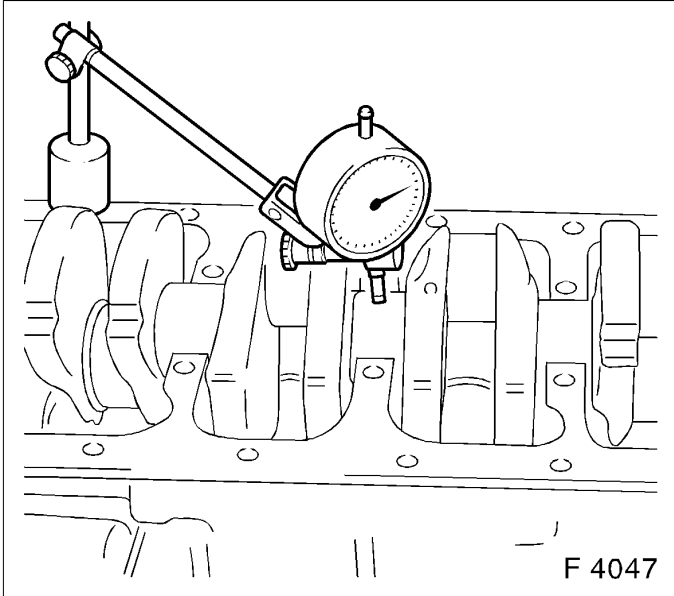

Crankshaft Bearing Play, Check (Determine Bearing Play with Plastigage)

Inspect

1. Bearing play – crankshaft bearing cap removed.

Important: To prevent thread from tearing when removing con-rod bearing cap, remove grease from con-rod journal and lightly oil con-rod bearing shell. Do not turn crankshaft.

Measure

1. With "Plastigage" (deformable plastic thread).
2. Cut thread to bearing width and lay axially between crankshaft journal and bearing shell (arrow). Install crankshaft bearing cap with torque –

Tighten

Tightening torque 50 Nm / 37 lb. ft. + 45° + 15°.

Notice: The bolts can be reused for checking crankshaft bearing clearance.

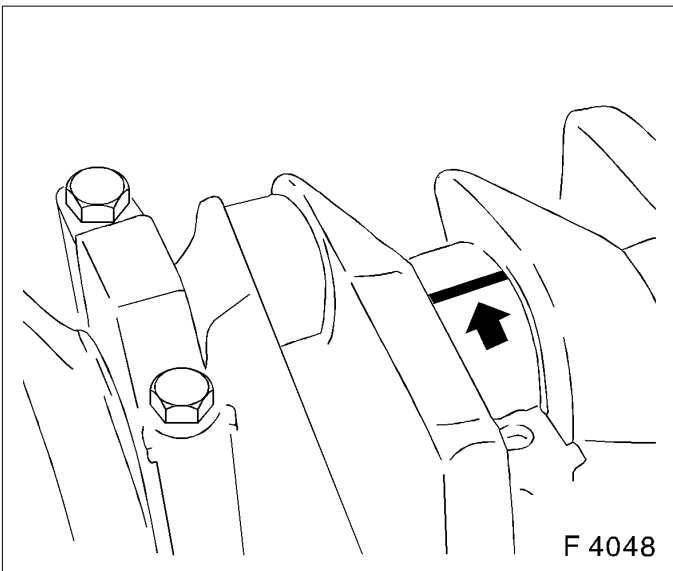

Removal Procedure

1. Remove crankshaft bearing cap.

Measure

1. Compare width of flattened plastic thread (arrow) with measuring scale.
 "Plastigage" is available for various measuring ranges.
 Perm. crankshaft bearing play: 0.015 to 0.041 mm.

Torque – Angle Method

1. Attach crankshaft bearing cap to cylinder block with new bolts.

Tighten

Tightening torque 50 Nm / 37 lb. ft. + 45° + 15°.

Crankshaft Bearing Clearance, Check (Determine Crankshaft Bearing Clearance Using External Micrometer and Inside Micrometer)

Notice: The crankshaft is removed.

Installation Procedure

1. Install crankshaft bearing cap with crankshaft bearing shell at cylinder block.

Tighten

Tightening torque 50 Nm / 37 lb. ft. + 45° + 15°. To check the crankshaft bearing play, bolt can be reused.

Measure

The average crankshaft bearing diameter is determined using an inside micrometer at points I, II and III and then calculated.

Formula for calculating the average crankshaft bearing diameter:

$$\frac{I + II + III}{3}$$

Example:

I	54.972 mm
II	54.981 mm
III	+ 54.984 mm
<hr/>	
	164.937 mm / 3 = 54.979 mm

The average crankshaft bearing diameter is 54.979 mm.

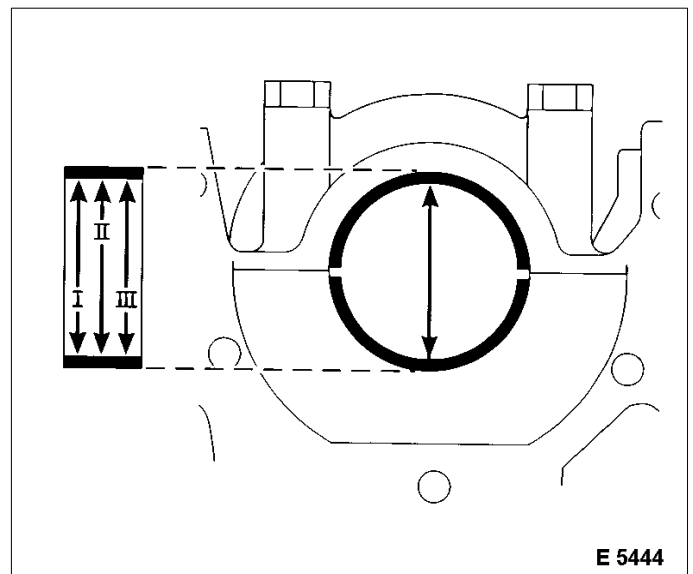
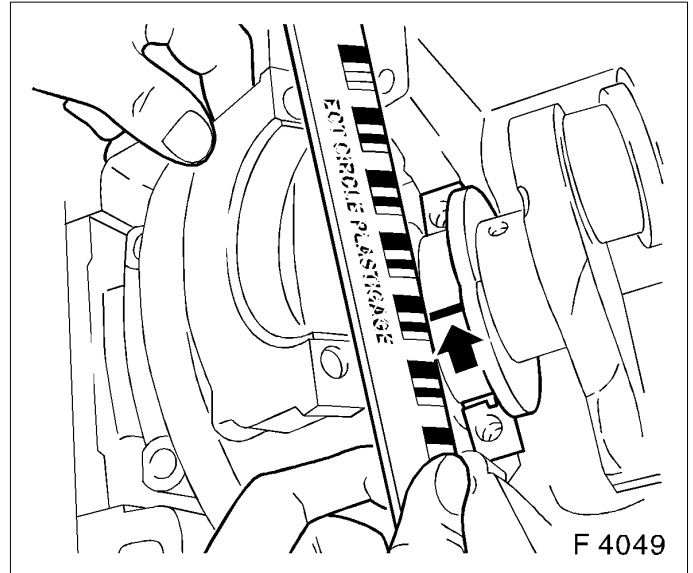

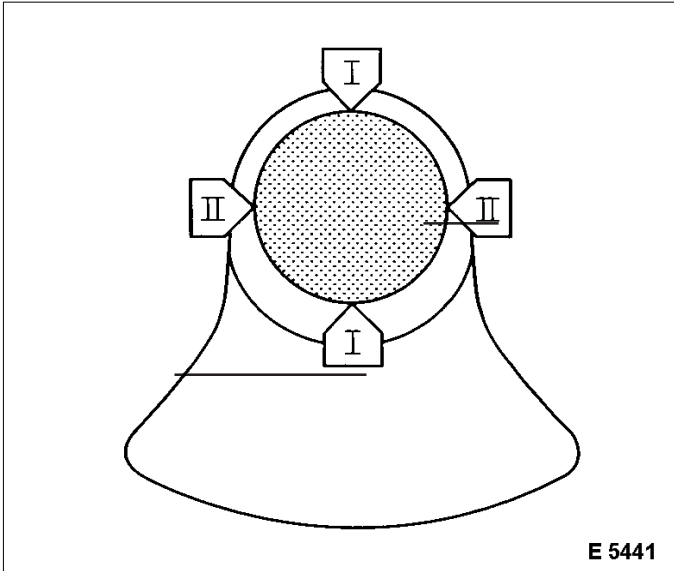
**Measure**

1. The crankshaft journal diameter is measured with a micrometer at points I and II and then calculated.

Formula for calculating the average crankshaft bearing journal diameter:

$$\frac{I + II}{2}$$

Example:

I	54.962 mm	
II	+54.964 mm	
	109.926 mm	/ 2 = 54.963 mm

The average crankshaft journal diameter is 54.963 mm.

The crankshaft clearance is calculated from the difference in diameter between the crankshaft bearing bore and crankshaft journal.

Example:

Average crankshaft bearing dia.	54.979 mm	
Average crankshaft journal dia.	– 54.963 mm	
	0.016 mm	

Permissible crankshaft bearing play: 0.015 to 0.041 mm.

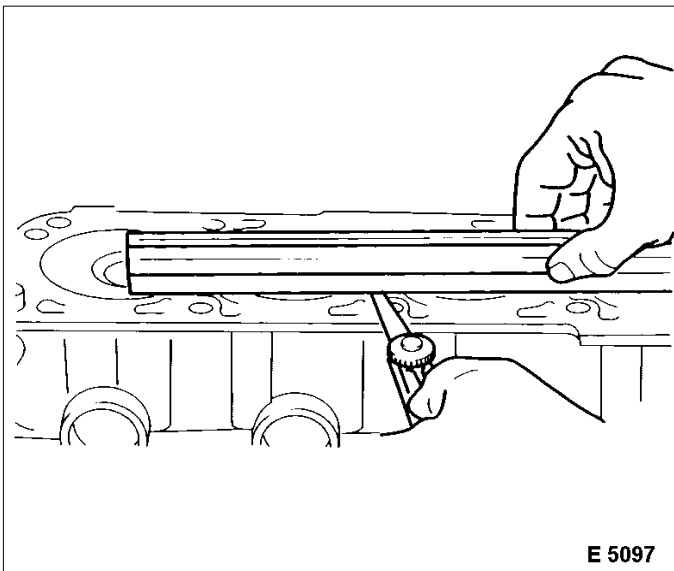
**Cylinder Block, Check for Plane Surface****Clean**

1. Clean sealing surface and remove sealant remnants.

Inspect

1. Check sealing surfaces in length and width for deformation and check for warping along the diagonals – use straight edge.

Oil Circuit

Oil Filter, Replace

Removal Procedure

1. Remove oil filter with KM-726-A (1) – place collecting basin underneath.

Installation Procedure

2. Coat seal ring of new oil filter lightly with engine oil and attach to cylinder block.

Tighten

Tightening torque 15 Nm / 11lb. ft.

Inspect

1. Check engine oil level and correct if necessary.

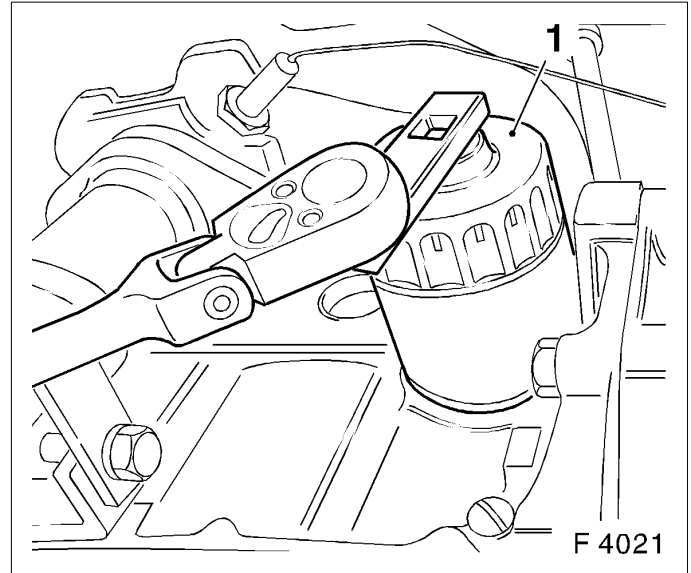

Bypass Valve, Replace

Removal Procedure

1. Remove oil filter – see operation *Oil Filter, Replace*.
2. Using tap (1) (M10 – 3rd speed) cut thread in shutter disc, screw in M10 bolt and remove bypass valve from seat.

Installation Procedure

1. Drive in bypass valve up to stop using drift (j approx. 15 mm).
2. Install oil filter – see operation *Oil Filter, Replace*.

Inspect

1. Check engine oil level and correct if necessary.

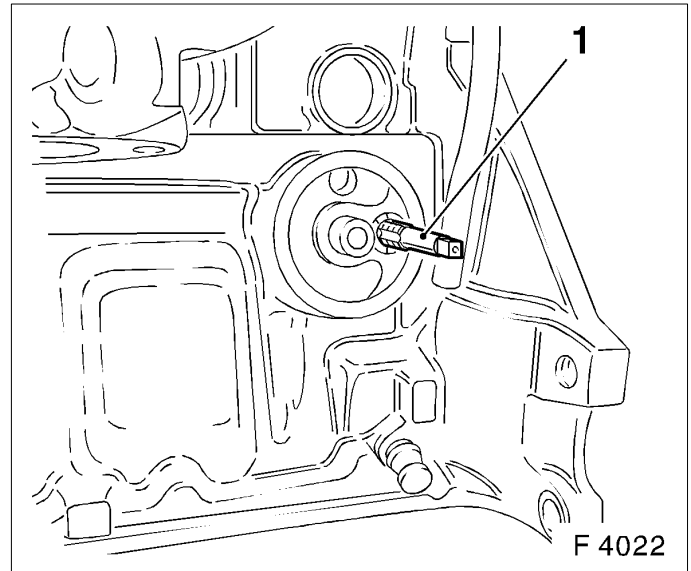

Front Seal Ring – Crankshaft, Replace

Removal Procedure

1. Remove upper part of toothed belt cover – see operation *Toothed Belt Cover – Upper Part, Remove and Install*.
2. Remove ribbed V-belts – see operation *Ribbed V-belts, Remove and Install*.
3. Remove lower part of toothed belt cover – see operation *Toothed Belt Cover – Lower Part, Remove and Install*.

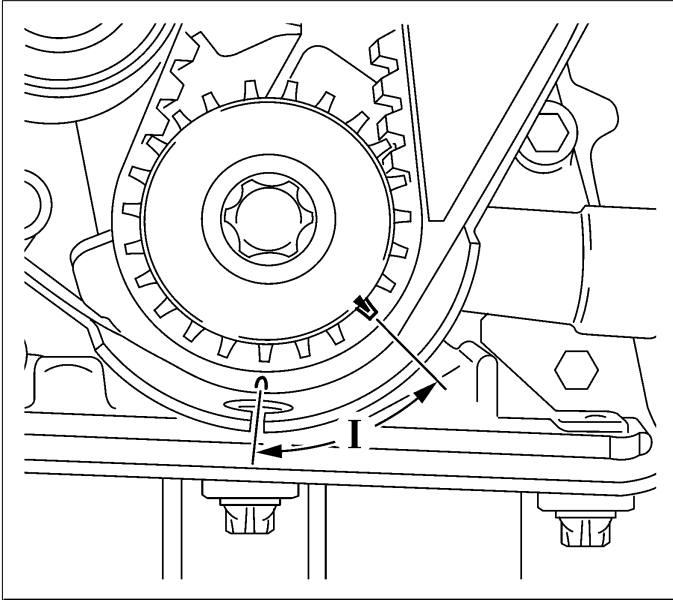

Important: Before dismantling the toothed belt – screw fastening bolt for toothed belt drive gear into crankshaft and move crankshaft in engine rotational direction by 60° (dimension l) to before TDC mark.

Removal Procedure

1. Remove toothed belt – see operation *Toothed Belt, Remove and Install*.
2. Remove fastening bolt from toothed belt drive gear and pull toothed belt drive gear from crankshaft.
3. Edge out crankshaft seal ring (1) with suitable tool.

Important: Do not damage sealing surfaces.

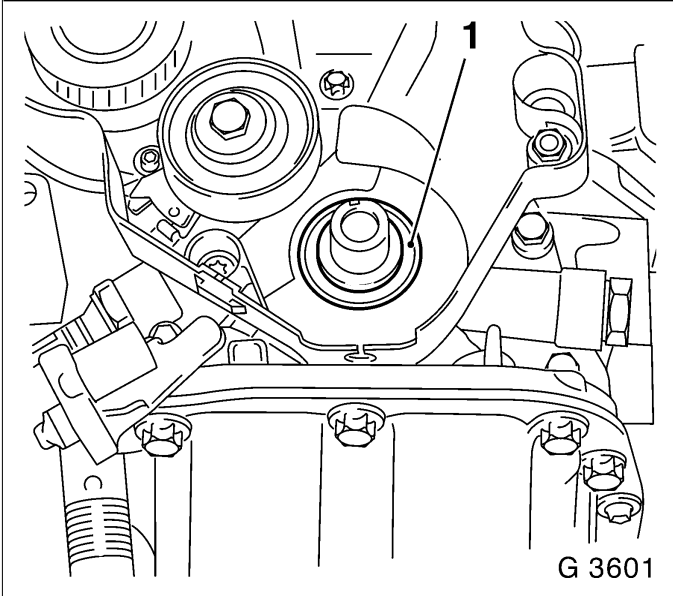

Installation Procedure

1. Slide Protective Sleeve KM-417 (1) onto crankshaft journal. Lightly coat sealing lip of the new seal ring with silicon grease (white) and slide over the protective sleeve onto crankshaft journal.

Removal Procedure

1. Remove protective sleeve of KM-417 from crank journal.

Installation Procedure

1. Press seal ring with KM-417 (3) in oil pump – use bolt (2) and washer (4) of toothed belt drive gear.
2. Slide toothed belt drive gear onto crankshaft.
3. Install toothed belt – see operation *Toothed Belt, Remove and Install*.
5. Install lower part of toothed belt cover – see operation *Toothed Belt Cover – Lower Part, Remove and Install*.
6. Install ribbed V-belt – see operation *Ribbed V-belt, Remove and Install*.
7. Install upper part of toothed belt cover – see operation *Toothed Belt Cover – Upper Part, Remove and Install*.

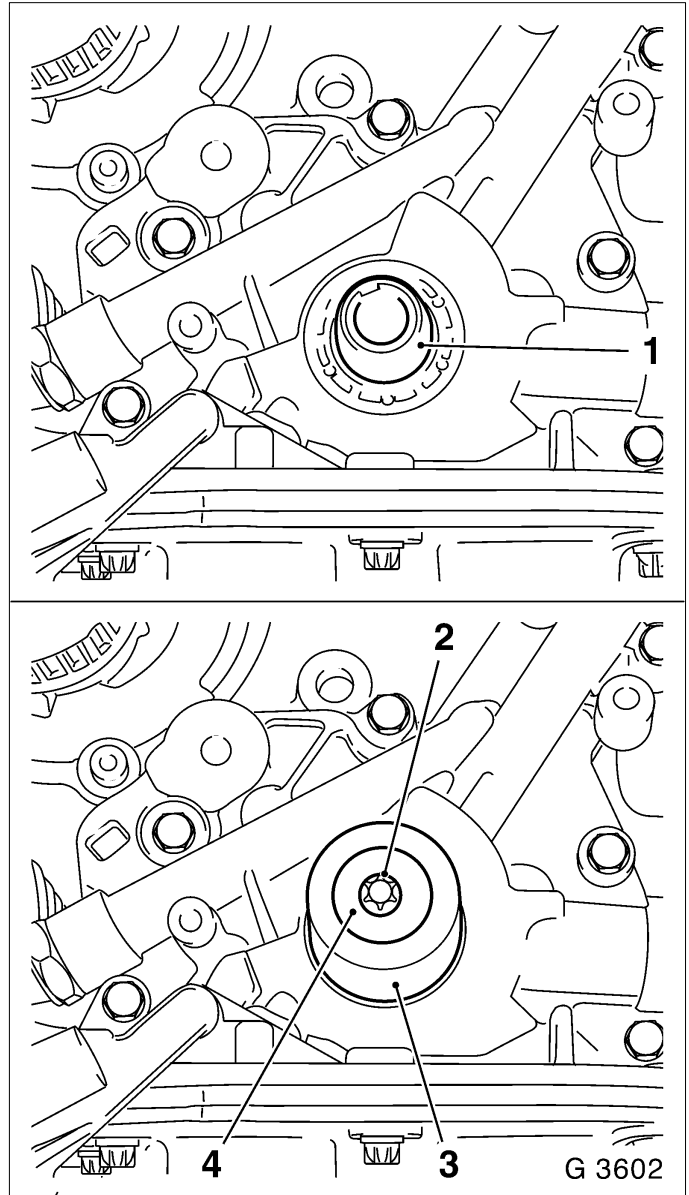

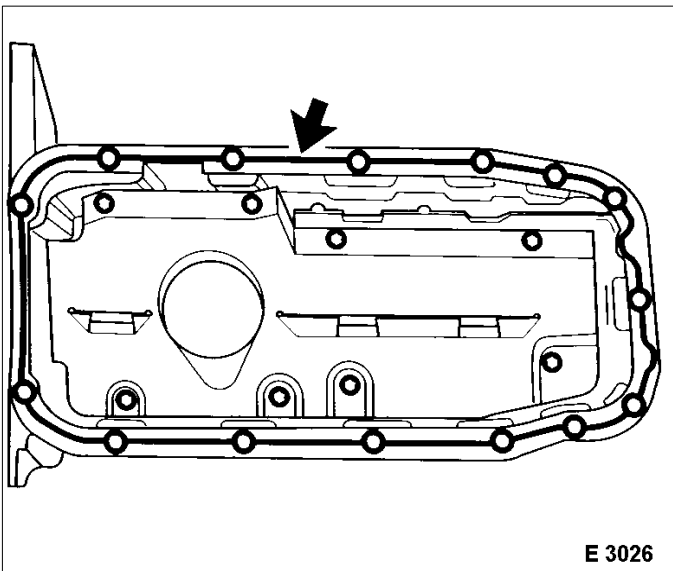
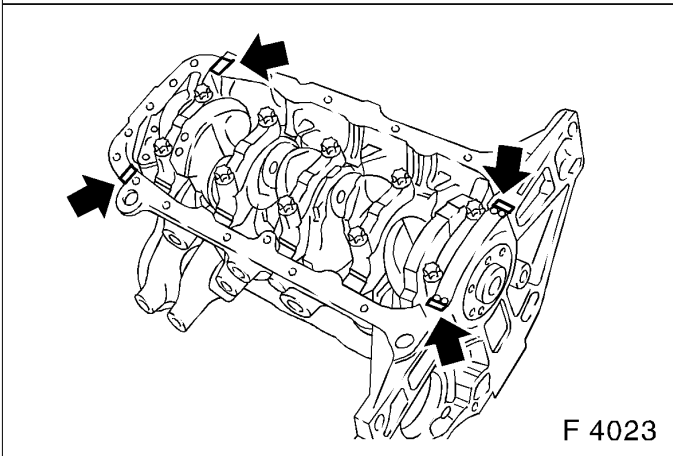
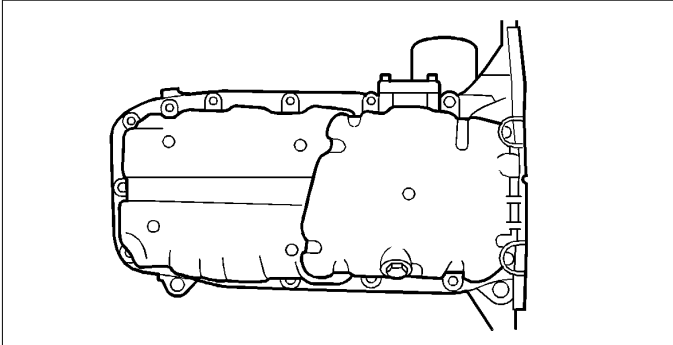
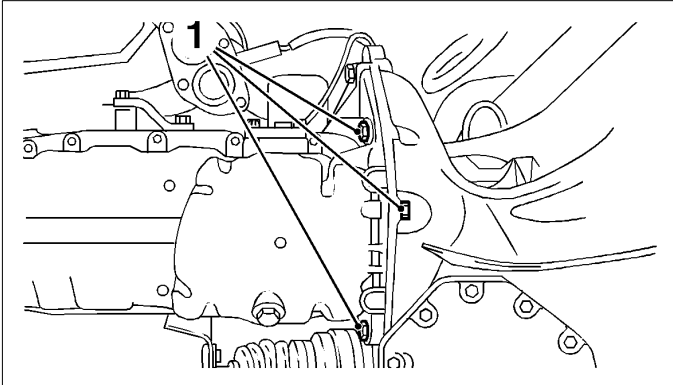

Oil Pan, Remove and Install

Removal Procedure

1. Open oil drain plug – place collecting basin underneath.
2. Remove oil pan from cylinder block and oil pump.

Clean

1. Clean sealing surfaces and remove gasket remnants.

Installation Procedure

1. Apply a bead of adhesive sealing compound (black) to joints of oil pump (shown by the position of the arrows in the illustration to the left) and rear crankshaft bearing cap.
2. Install oil pan with new gasket (shown by the arrow in the illustration on the lower left) to oil pump and cylinder block. Attach oil drain plug to oil pan with new seal ring.

Tighten

Tightening torque 55 Nm / 40.6 lb. ft.

Important:

Installation sequence:

1. Tighten all bolts loosely.
2. Tighten bolts on cylinder block and oil pump.

Tighten

Tightening torque 10 Nm / 7.5 lb. ft.1).

3. Recut thread before reuse and insert bolts with screw locking compound (red). The installation time including the torque check is max. 10 min.

For version with hex bolts.

Tighten

Tightening torque 35 Nm / 26 lb. ft.1).

For version with hex nuts.

Tighten

Tightening torque 45 Nm / 33 lb. ft.2).

4. Fill engine oil up to "MAX" at dipstick.
- 1) Insert bolts with mounting paste (white).
- 2) Use new nut(s).

Oil Pump, Remove and Install

Important: Prior to removing toothed belt – set crankshaft to approx. 60° (dimension I) before TDC mark.

Removal Procedure

1. Remove oil pan – see operation *Oil Pan, Remove and Install*.
2. Remove upper part of toothed belt cover – see operation *Toothed Belt Cover – Upper Part, Remove and Install*.
3. Remove ribbed V-belts – see operation *Ribbed V-belts, Remove and Install*.
4. Remove lower part of toothed belt cover – see operation *Toothed Belt Cover – Lower Part, Remove and Install*.
5. Remove toothed belt – see operation *Toothed Belt, Remove and Install*.
6. Remove toothed belt tension roller – see operation *Toothed Belt Tension Roller, Remove and Install*.
7. Remove rear toothed belt cover – see operation *Toothed Belt Cover – Rear, Remove and Install*.
8. Remove oil intake tube (1) from oil pump and cylinder block.
9. Disconnect wiring harness plug (2) from oil pressure switch.
10. Detach oil pump (4) from cylinder block.
11. Edge seal ring (5) out of oil pump.

Clean

1. Clean sealing surfaces and remove gasket remnants.

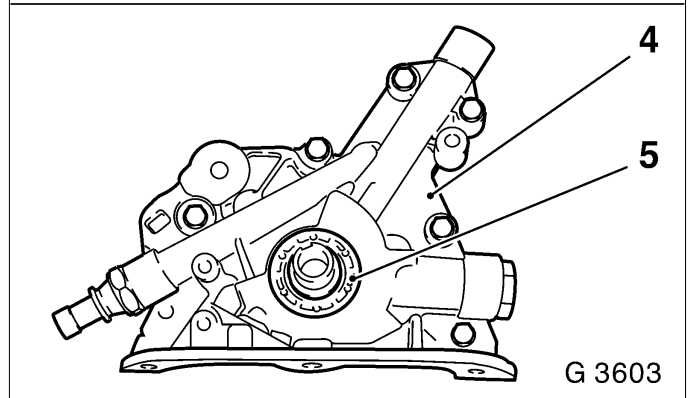
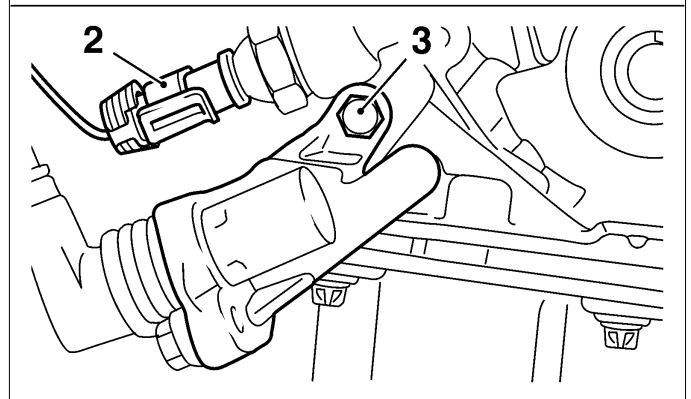
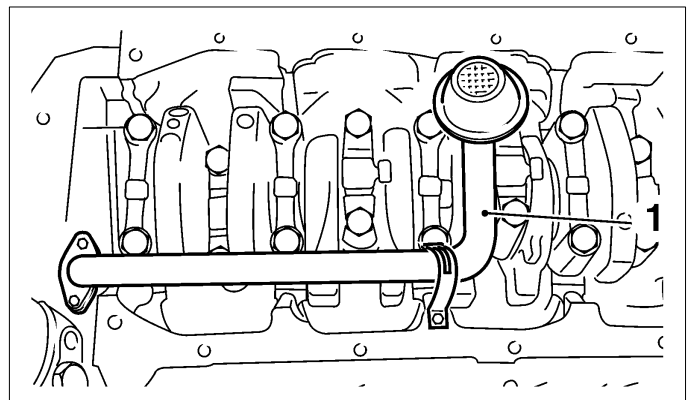
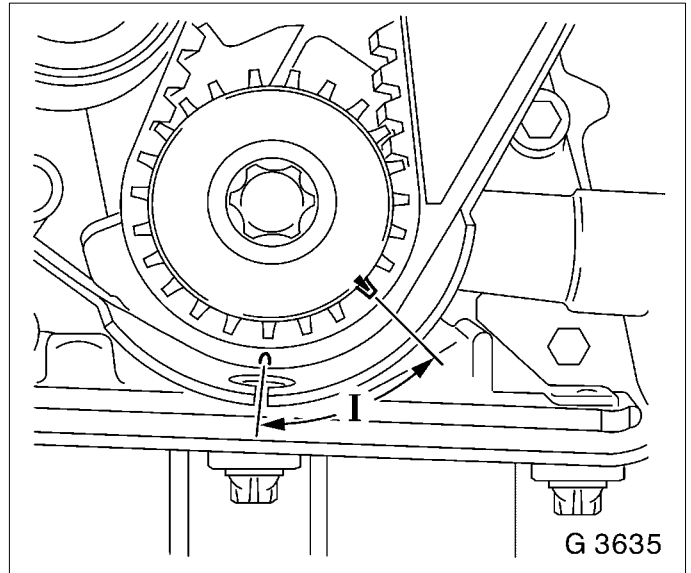

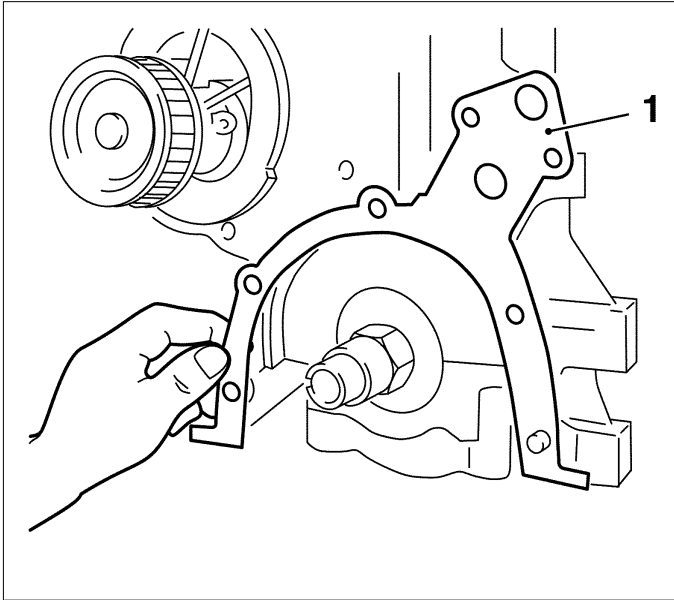

Installation Procedure

1. Attach oil pump with new seal (1) to cylinder block.

Tighten

Tightening torque 10 Nm / 7 lb. ft.

2. Slide Protective Sleeve KM-417 onto crankshaft journal.
3. Lightly coat sealing lip of the new seal ring with silicon grease (white) and slide over the protective sleeve onto crankshaft journal.

Removal Procedure

1. Remove protective sleeve from crankshaft journal.

Installation Procedure

1. Press seal ring with KM-417 (3) in oil pump – use bolt (2) and washer (4) of toothed belt drive gear.
2. Connect wiring harness plug to oil pressure switch.
3. Attach oil intake manifold to oil pump with new seal ring

Tighten

Tightening torque 8 Nm / 6 lb. ft.1).

4. Attach oil intake manifold to cylinder block.

Tighten

Tightening torque 8 Nm / 6 lb. ft.

5. Install rear toothed belt cover – see operation *Toothed Belt Cover – Rear, Remove and Install*.
6. Install toothed belt tension roller – see operation *Toothed Belt Tension Roller, Remove and Install*.
7. Install toothed belt – see operation *Toothed Belt, Remove and Install*.
8. Install lower part of toothed belt cover – see operation *Toothed Belt Cover – Lower Part, Remove and Install*.
9. Install ribbed V-belt – see operation *Ribbed V-belt, Remove and Install*.
10. Install upper part of toothed belt cover – see operation *Toothed Belt Cover – Upper Part, Remove and Install*.
11. Install oil pan – see operation *Oil Pan, Remove and Install*.

1) Recut thread before reuse and insert bolts with screw locking compound (red). The installation time including the torque check is max. 10 min.

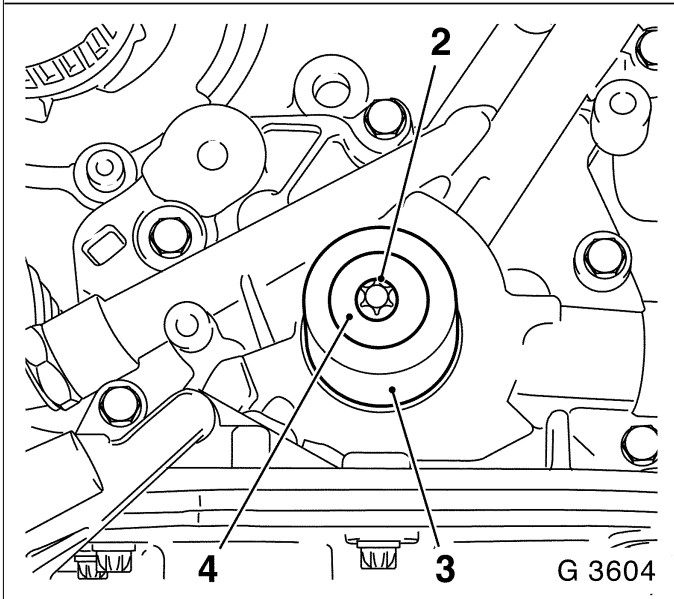

Oil Pump, Check

Removal Procedure

1. Remove oil pan – see operation *Oil Pan, Remove and Install*.
2. Remove upper part of toothed belt cover – see operation *Toothed Belt Cover – Upper Part, Remove and Install*.
3. Remove ribbed V-belts – see operation *Ribbed V-belts, Remove and Install*.
4. Remove lower part of toothed belt cover – see operation *Toothed Belt Cover – Lower Part, Remove and Install*.
5. Remove toothed belt – see operation *Toothed Belt, Remove and Install*.
6. Remove toothed belt tension roller – see operation *Toothed Belt Tension Roller, Remove and Install*.
7. Rear toothed belt cover – see operation *Toothed Belt Cover – Rear, Remove and Install*.
8. Remove oil pump – see operation *Oil Pump, Remove and Install*.
9. Remove safety valve (1) and oil pump cover (2) from oil pump.

Inspect

1. Check gap of gear pair with feeler gauge (4) and straight edge (3). Dimension – 0.08 to 0.15 mm.
2. Check oil pump, oil pump cover and safety valve for signs of wear.

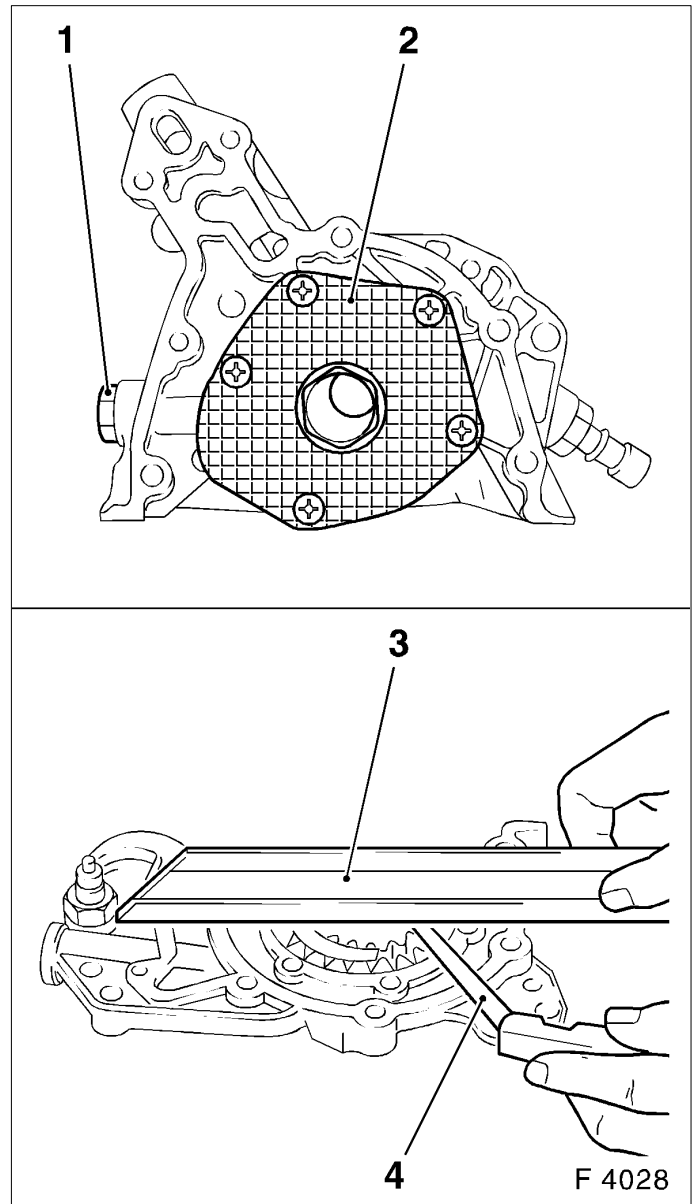

Installation Procedure

1. Oil pump cover to oil pump.

Tighten

Tightening torque 6 Nm / 4 lb. ft.

2. Install safety valve with new seal ring in oil pump.

Tighten

Tightening torque 50 Nm / 37 lb. ft.

3. Install oil pump – see operation *Oil Pump, Remove and Install*.
4. Install rear toothed belt cover – see operation *Toothed Belt Cover – Rear, Remove and Install*.
5. Install toothed belt tension roller – see operation *Toothed Belt Tension Roller, Remove and Install*.
6. Install toothed belt – see operation *Toothed Belt, Remove and Install*.
7. Install lower part of toothed belt cover – see operation *Toothed Belt Cover – Lower Part, Remove and Install*.
8. Install ribbed V-belt – see operation *Ribbed V-belt, Remove and Install*.
9. Install upper part of toothed belt cover – see operation *Toothed Belt Cover – Upper Part, Remove and Install*.
10. Install oil pan – see operation *Oil Pan, Remove and Install*.

Safety Valve, Remove and Install

Removal Procedure

1. Remove closure plug (1) from oil pump.
2. Remove seal ring, spring, piston from oil pump.

Installation Procedure

1. Insert piston (2) – ensure installation position is correct.
2. Insert spring (3) in oil pump.
3. Attach closure plug (5) to oil pump with new seal ring (4).

Tighten

Tightening torque 50 Nm / 37 lb. ft.

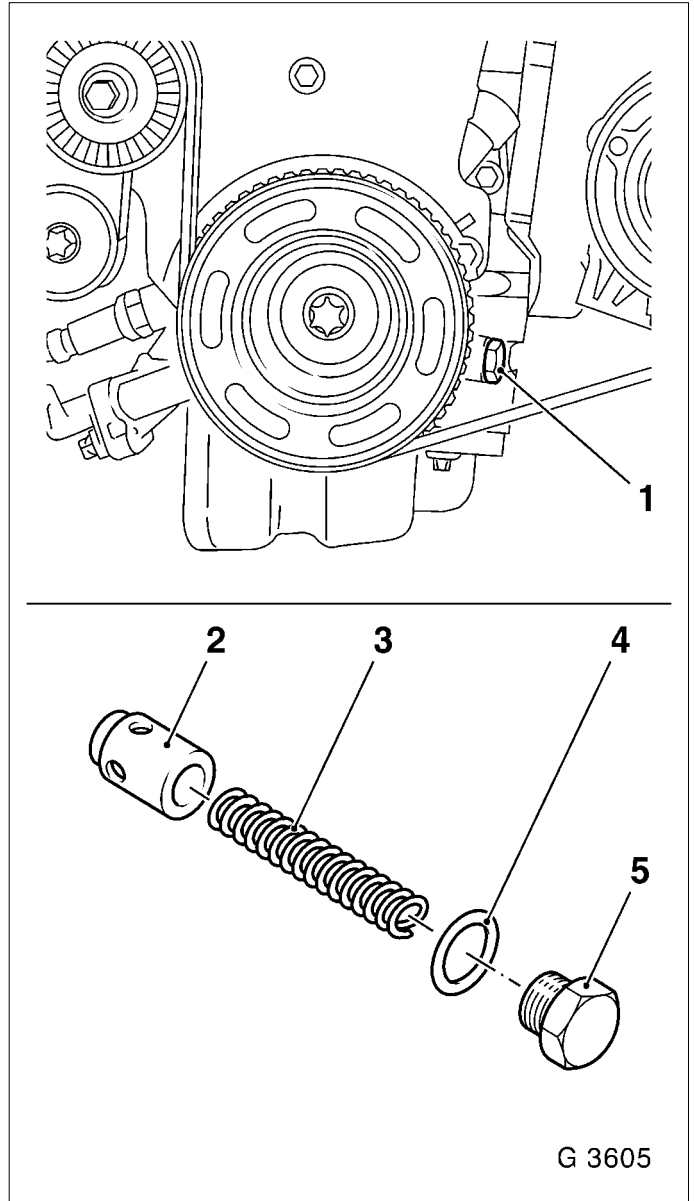

Oil Intake Pipe, Remove and Install

Removal Procedure

1. Remove oil pan – see operation *Oil Pan, Remove and Install*.
2. Remove oil intake tube (1) from oil pump and cylinder block.

Installation Procedure

1. Attach oil intake manifold to oil pump with new seal ring.

Tighten

Tightening torque 8 Nm / 6 lb. ft.1).

2. Attach oil intake manifold to cylinder block.

Tighten

Tightening torque 8 Nm / 6 lb. ft.

3. Install oil pan – see operation *Oil Pan, Remove and Install*.

1) Recut thread before reuse and insert bolts with screw locking compound (red). The installation time including the torque check is max. 10 min.

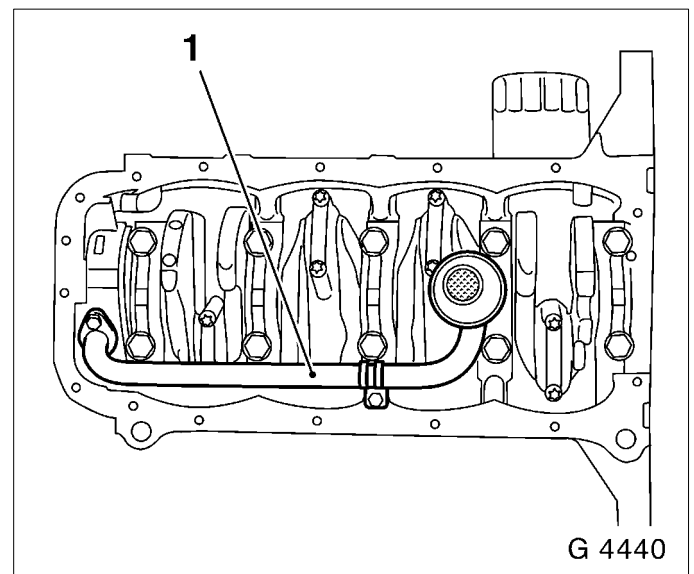

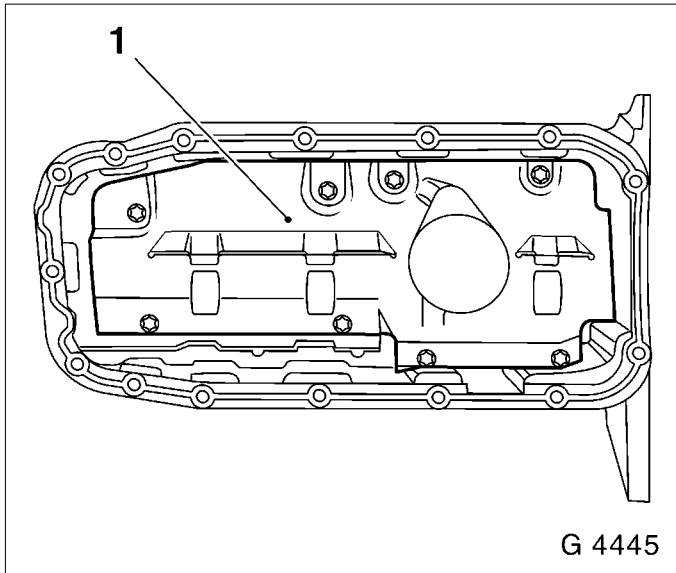

Oil Baffle Plate, Remove and Install

Removal Procedure

1. Remove oil pan – see operation *Oil Pan, Remove and Install*.
2. Remove oil baffle plate (1).

Installation Procedure

1. Attach oil baffle plate to oil pan.

Tighten

Tightening torque 8 Nm / 6 lb. ft.

2. Install oil pan – see operation *Oil Pan, Remove and Install*.

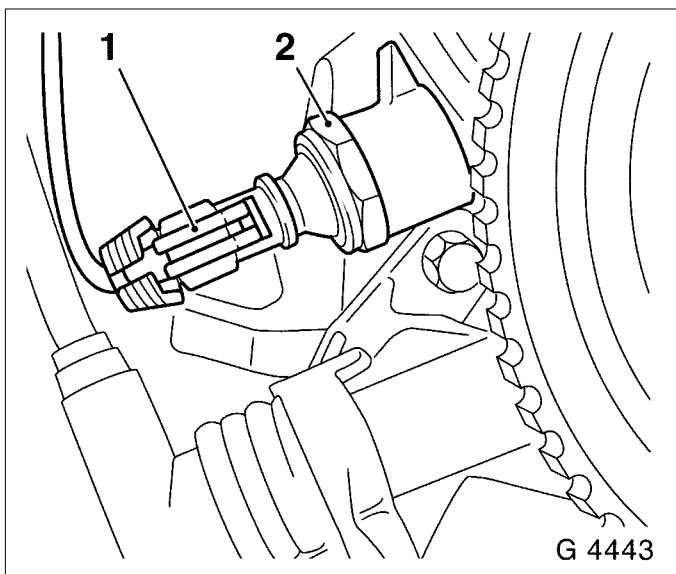

Oil Pressure Switch, Remove and Install

Removal Procedure

1. Detach wiring harness plug (1) from oil pressure switch.
2. Disconnect oil pressure switch (2) from oil pump – place collection pan underneath.

Installation Procedure

1. Attach oil pressure switch to oil pump with new seal ring.

Tighten

Tightening torque 30 Nm / 22 lb. ft.

2. Connect wiring harness plug to oil pressure switch.

Inspect

1. Check engine oil level and correct if necessary.

Oil Dipstick Guide Tube, Remove and Install

Removal Procedure

1. Withdraw oil dipstick guide tube (1) from cylinder block.

Installation Procedure

1. Push new seal ring (2) onto oil dipstick guide tube and lightly coat with engine oil.
2. Insert oil dipstick guide tube up to stop in cylinder block.

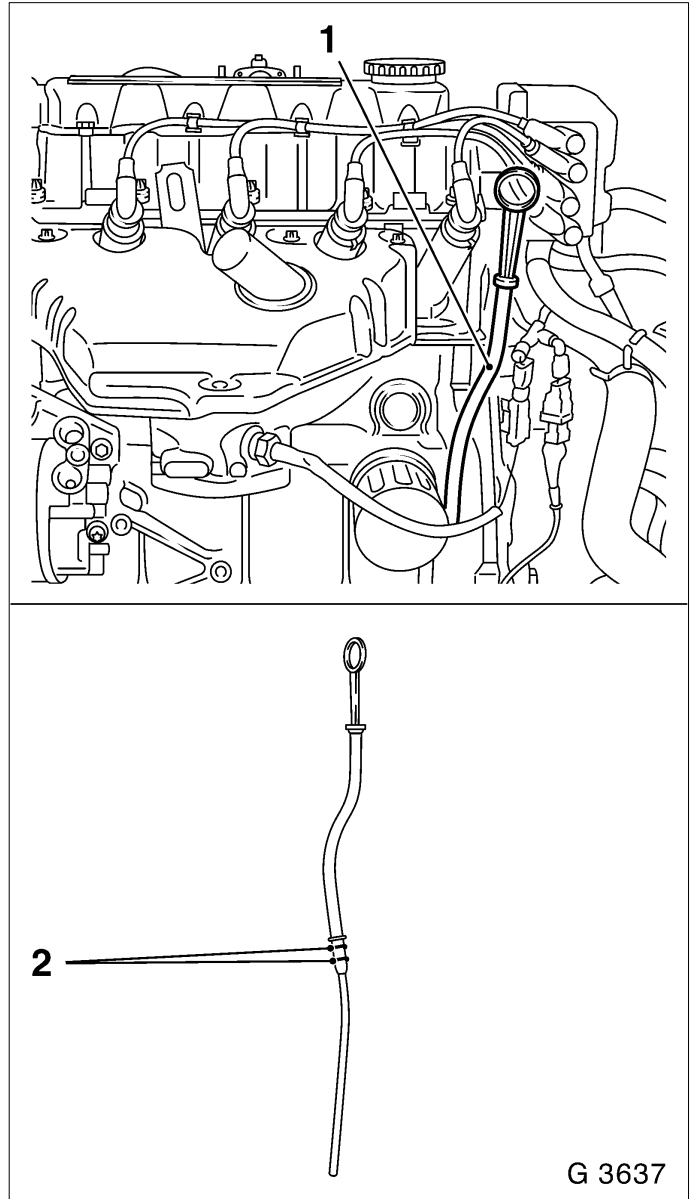

Crankshaft Position Sensor, Remove and Install

Refer to operation *Crankshaft Position Sensor, Remove and Install* in Section 3, Engine Electrical.

Reference Gap Between Crankshaft Position Sensor and Increment Disc, Check

Refer to operation *Reference Gap Between Crankshaft Position Sensor and Increment Disc, Check* in Section 3, Engine Electrical.

Coolant Thermostat, Remove and Install

Refer to operation *Coolant Thermostat, Remove and Install* in Section 2, Engine Cooling.

Coolant Pump, Remove and Install

Refer to operation *Coolant Pump, Remove and Install* in Section 2, Engine Cooling.

Fuel Pressure, Check

Important: Fuel escapes. Observe safety regulations and national legislation.

Installation Procedure

1. Connect Pressure Gauge KM–J–34730–91 (1) to test connection (2).
2. Start engine and bleed pressure gauge – idle speed. Collect escaping fuel in a suitable container.

Inspect

1. Check fuel pressure.
2. Start engine and allow to run at idle speed. Nominal value – see relevant Checking Procedures.

Removal Procedure

1. Detach pressure gauge from test connection.

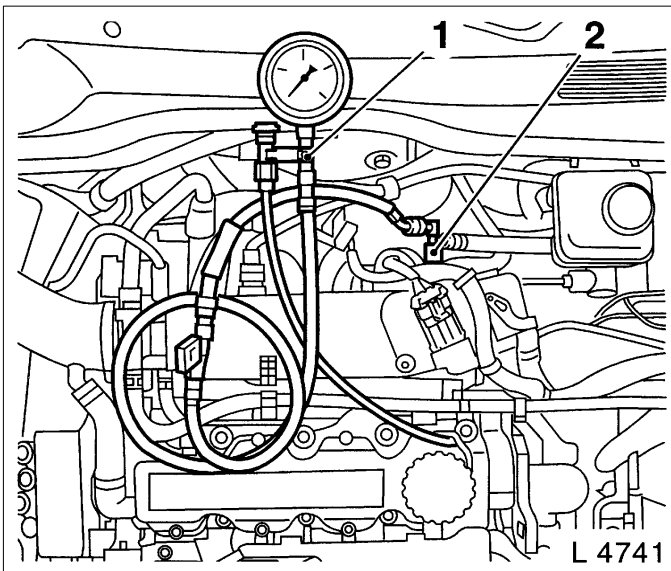

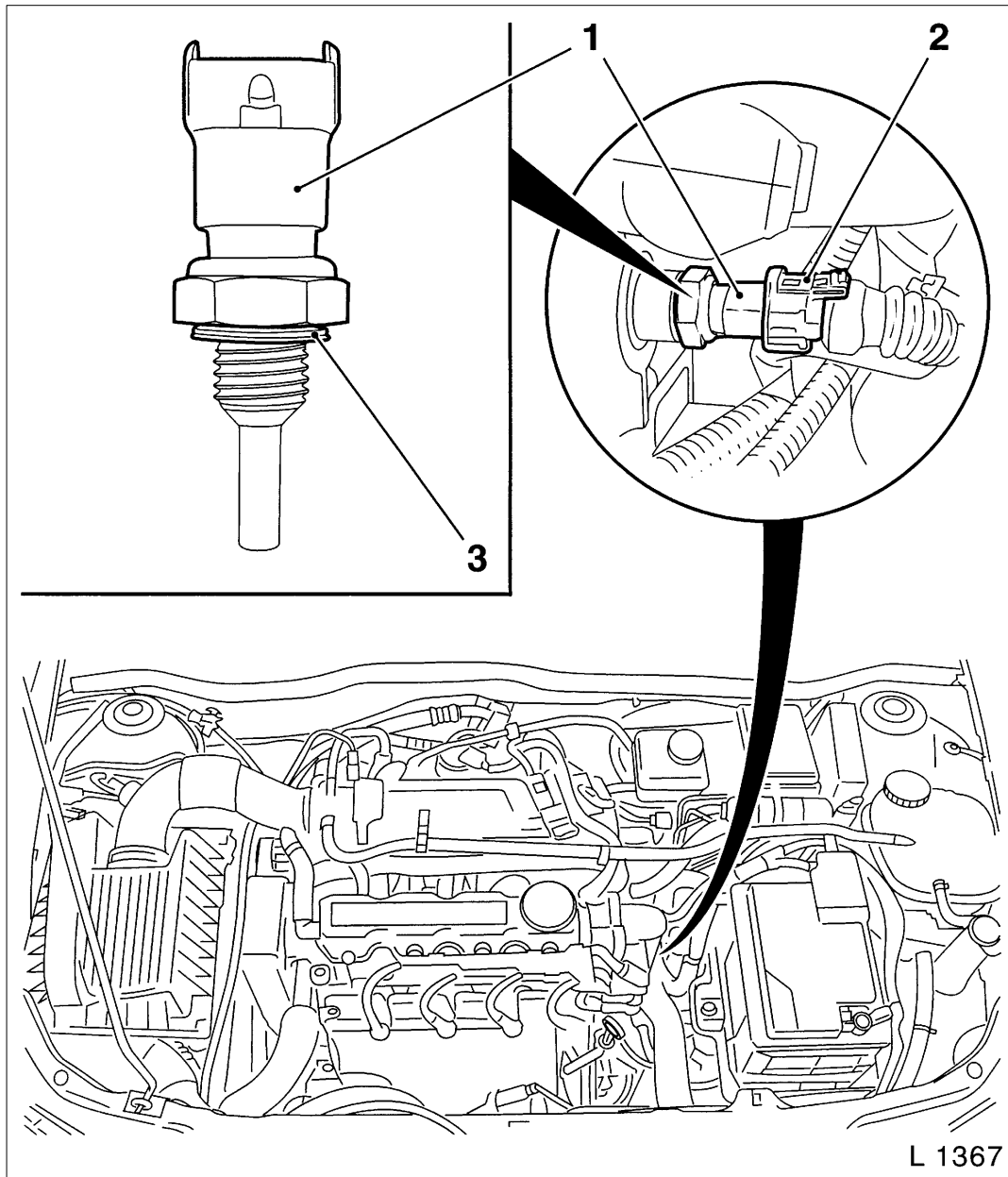

Coolant Temperature Sensor, Remove and Install

Removal Procedure

1. Open coolant drain bolt – collect escaping coolant.
2. Detach wiring harness plug (2).
3. Detach coolant temperature sensor (1) from cylinder head.

Clean

1. Clean sealing surfaces and remove gasket remnants.

Installation Procedure

1. Attach coolant temperature sensor to cylinder head with new seal ring (3).

Tighten

Tightening torque 20 Nm / 15 lb. ft.

2. Connect wiring harness plug to coolant temperature
3. Close coolant drain bolt.

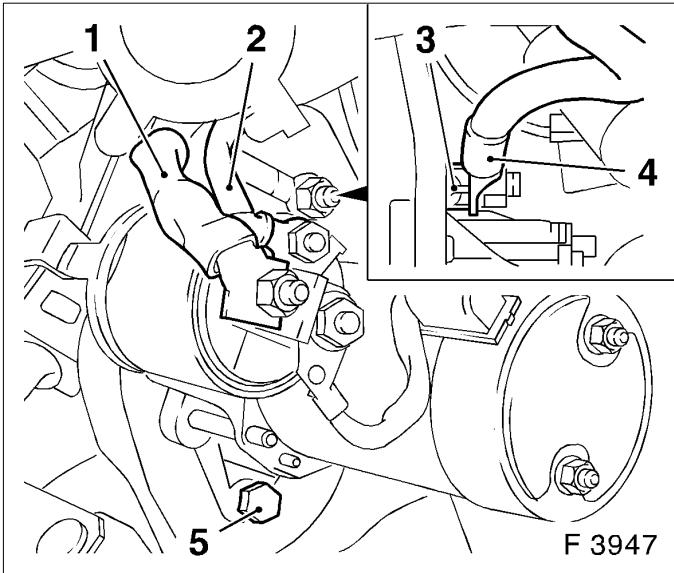

Starter

Starter, Remove and Install

Removal Procedure

1. Disconnect negative battery cable.
2. Remove cable connections (1) and (2) from starter.
3. Remove ground cable (4).
4. Remove fastening nut (3) and fastening bolt (5) from starter.
5. Remove starter.

Installation Procedure

1. Install starter and fastening bolts.

Tighten

Tightening torque 25 Nm / 18.5 lb. ft.

3. Connect ground cable.
4. Install cable connections on starter – ensure correct cable routing.
5. Attach negative battery cable.

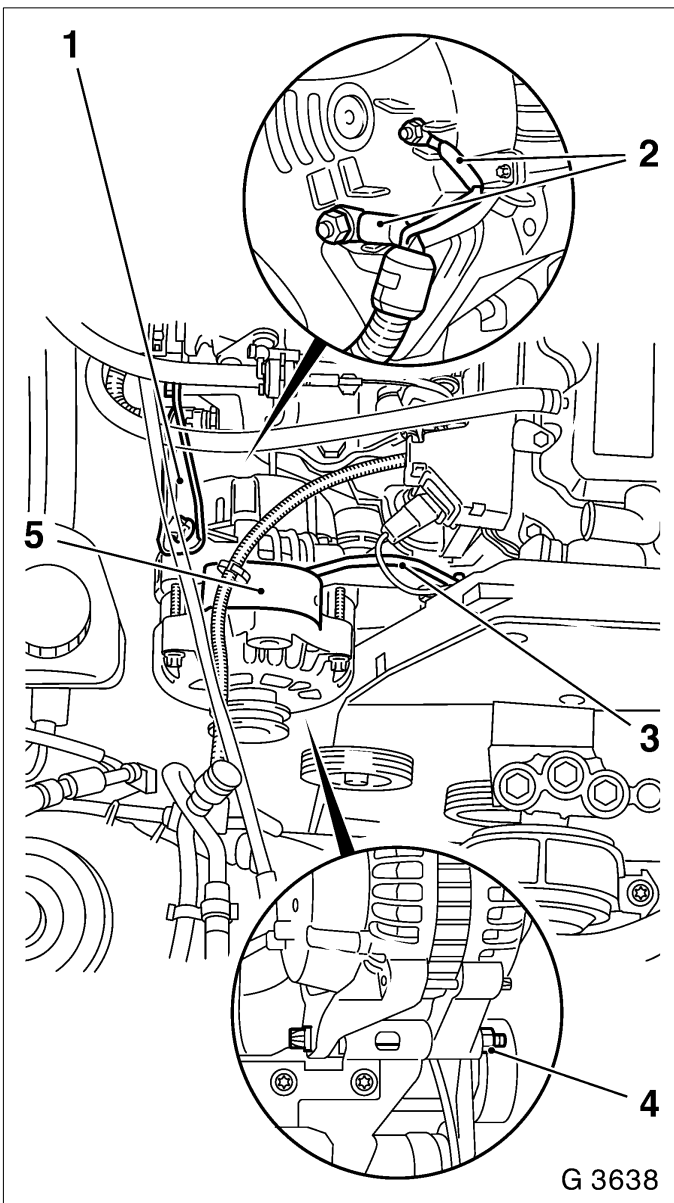

Alternator

Alternator, Remove and Install

Removal Procedure

1. Remove ribbed V-belts – see operation *Ribbed V-belts, Remove and Install*.
2. Remove alternator support (1) from alternator and intake manifold.
3. Release alternator from alternator shackle (3) with wiring harness bracket (5) and swing rearward.
4. Unclip cable bunch from cable bunch bracket and remove cable bunch bracket.
5. Remove cable connections (2) from alternator.
6. Remove lower alternator fastening bolt (4) and remove alternator from alternator support.

Installation Procedure

1. Position alternator in alternator support and hand-tighten lower alternator fastening bolt.
2. Attach cable connections to alternator.
3. Attach alternator and wiring harness bracket to alternator shackle.

Tighten

Tightening torque 20 Nm/ 15 lb. ft.

4. Clip cable bundle to cable bundle bracket.
5. Attach alternator support to alternator and intake manifold.

Tighten

Tightening torque 20 Nm / 15 lb. ft.

6. Install lower alternator fastening bolt.

Tighten

Tightening torque 35 Nm/ 26 lb. ft.

7. Install ribbed V-belt – see operation *Ribbed V-belt, Remove and Install*.

Special Tools and Equipment

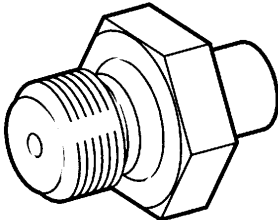
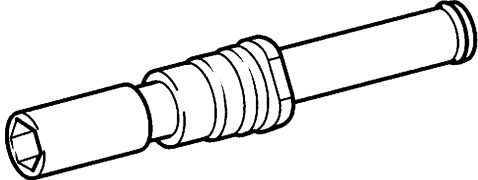
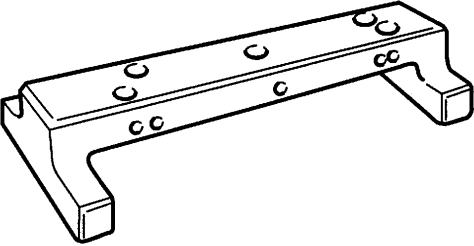
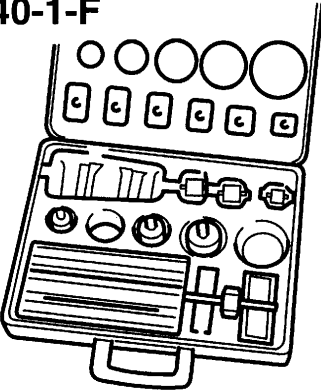
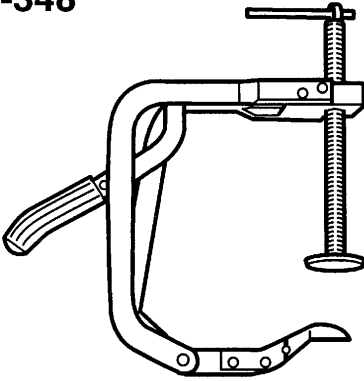
<p>KM-135</p> 	<p>KM-194-E</p> 
<p>KM-301</p> 	<p>KM-340-1-F</p> 
<p>KM-348</p> 	<p style="text-align: right;">L 2223</p>

KM-135 Adapter

To measure engine oil pressure in conjunction with KM-498-B

KM-194-E Spark Plug Key

To remove and install spark plugs, A/F 16 mm

KM-301 Gauge Bar

To check piston projection

KM-340-1-F Cutter Set

To mill, rework valve seats

KM-348 Spring Compressor

To compress valve springs, cylinder head removed

Special Tools and Equipment (Continued)

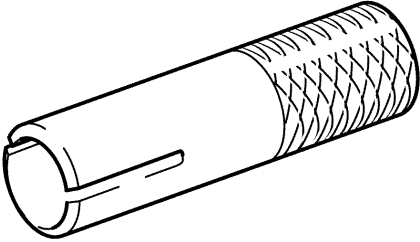
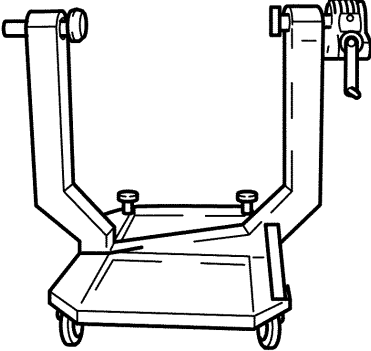
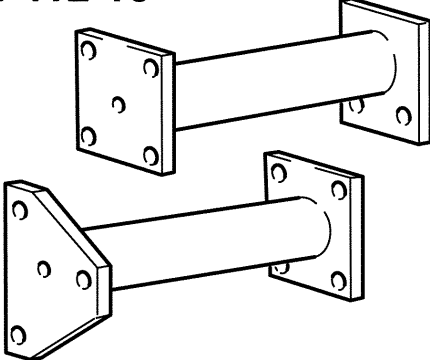
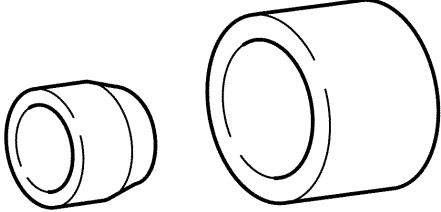
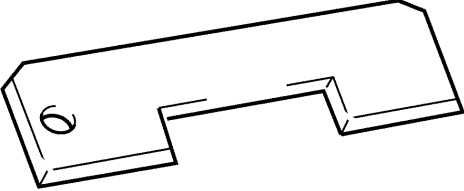
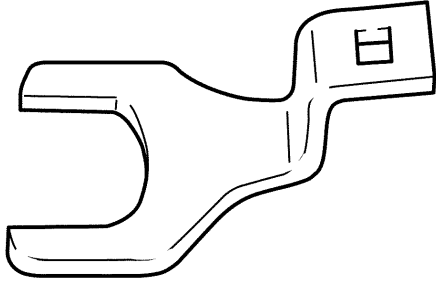
<p>KM-352</p> 	<p>KM-412</p> 
<p>KM-412-10</p> 	<p>KM-417</p> 
<p>KM-419</p> 	<p>KM-421-A</p>  <p style="text-align: right;">G 3692</p>

KM-352 Installer
To install valve stem sealing

KM-412 Engine Overhaul Stand
To hold removed engine

KM-412-10 Adapter
To hold engine in conjunction with KM-412

KM-417 Assembly Sleeves
To press crankshaft seal ring into oil pump housing

KM-419 Distance Gauge
To check valve stem projection

KM-421-A Adjusting Wrench
To adjust toothed belt tension

Special Tools and Equipment (Continued)

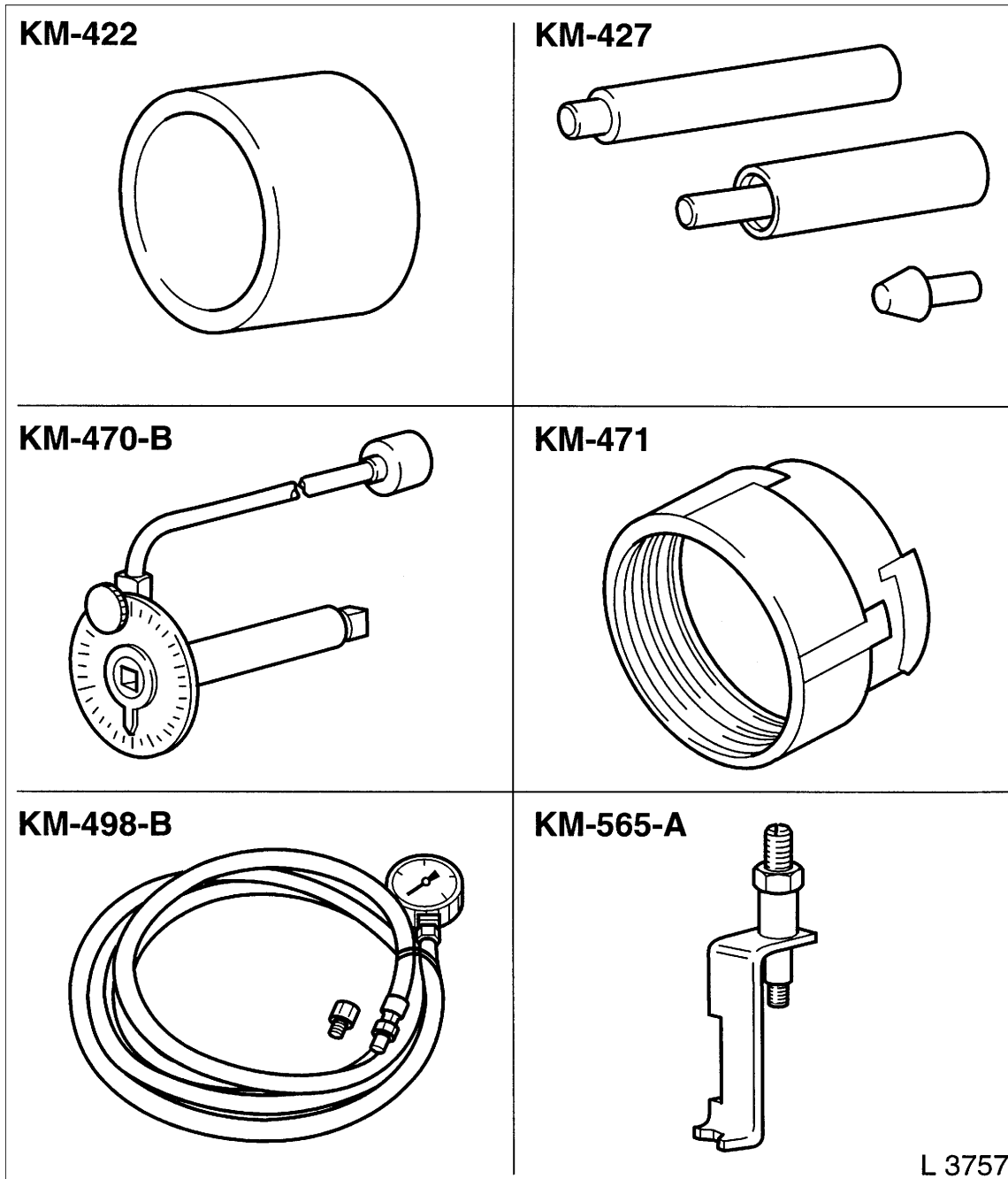
**KM-422 Installer**

To press seal ring in camshaft housing

KM-427 Remover / Installer

To install guide pins into engine block

KM-470-B Angular Torque Wrench

To tighten cylinder head bolts

KM-471 Adapter

To check pressurized cooling system in conjunction with cooling system tester

KM-498-B Oil pressure gauge

To check engine oil pressure in conjunction with KM-135

KM-565-A Remover / Installer

To remove and install rocker arms and valve play compensator

Special Tools and Equipment (Continued)

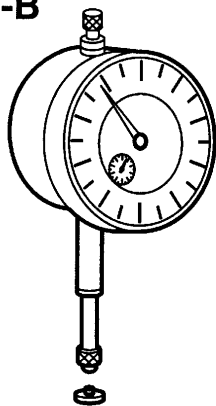
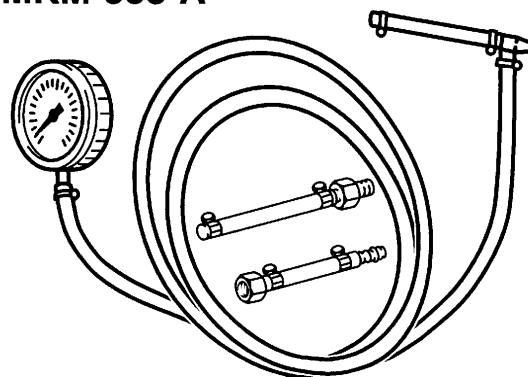
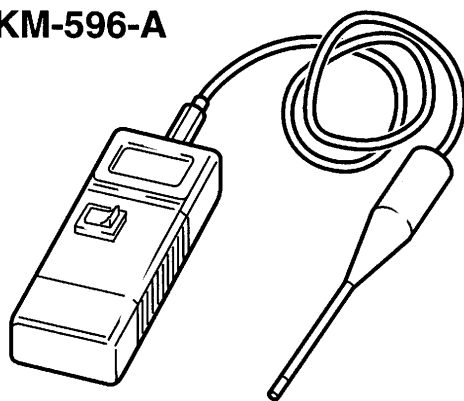
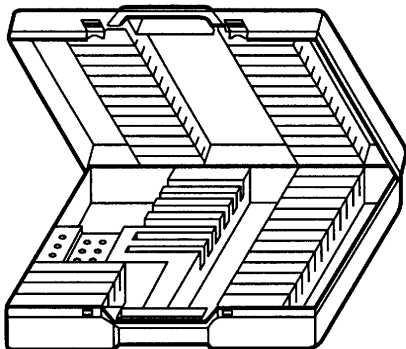
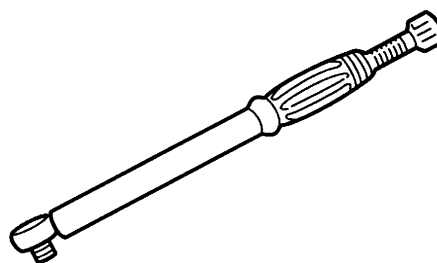
MKM-571-B**MKM-588-A****MKM-596-A****MKM-604-D****KM-609****MKM-610**

L 2224

MKM-571-B Dial Gauge

To measure piston projection

MKM-588-A Pressure Gauge

To check fuel pressure

MKM-596-A Temperature Gauge

To measure oil temperature, exhaust gas special test (German AU)

MKM-604-D Torx Bit and Socket Set

To remove/install Torx bolts

KM-609 Electronic Kit I

Diagnosis of electric and electronic systems

MKM-610 Torque Wrench, 1/2"

Range 30 – 130 Nm / 22 – 96 lb. ft.

Special Tools and Equipment (Continued)

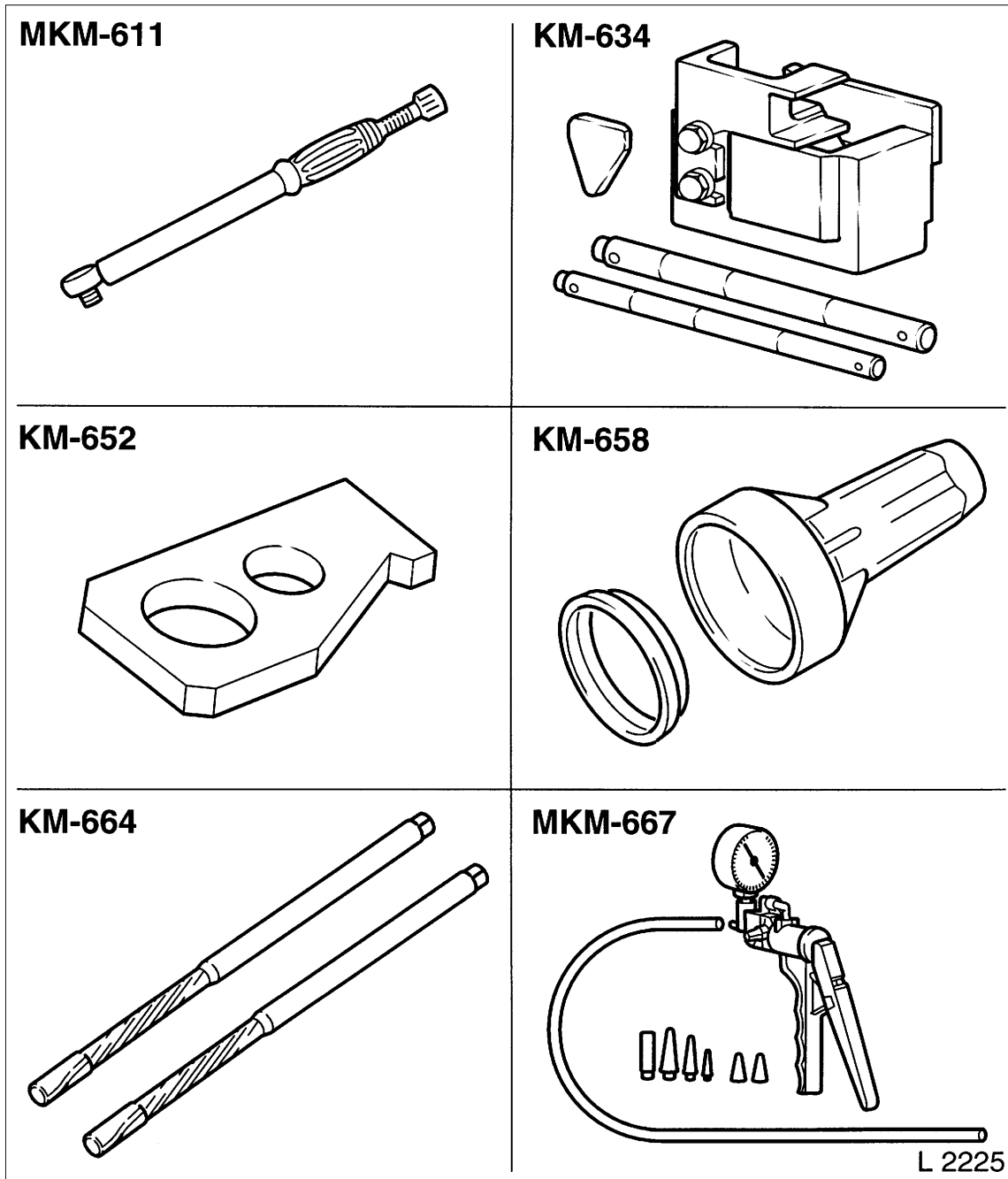

MKM-611 Torque Wrench, 3/8"
Range 10 – 60 Nm / 7 – 44 lb. ft.

KM-634 Remover / Installer
To remove/install piston pin

KM-652 Flywheel Holder
To lock flywheel/drive disc

KM-658 Installer
To install crankshaft rear seal ring

KM-664 Reamer Set 7 mm
Valve guide ream (j 7 mm)

MKM-667 Pressure and Vacuum Pump
To check for leaks in vacuum unit

Special Tools and Equipment (Continued)

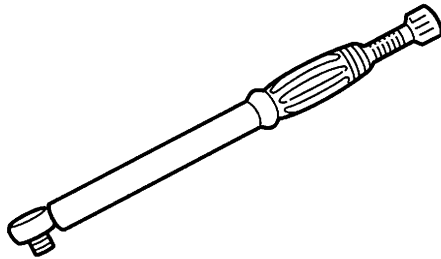
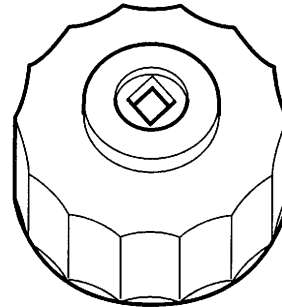
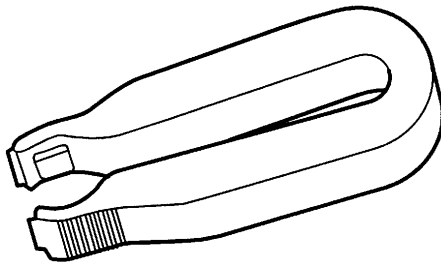
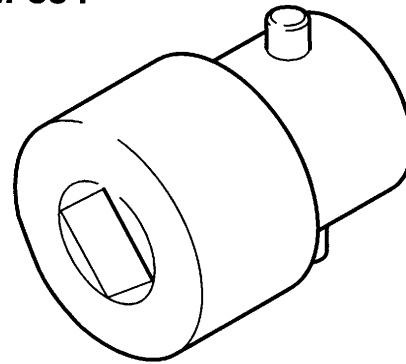
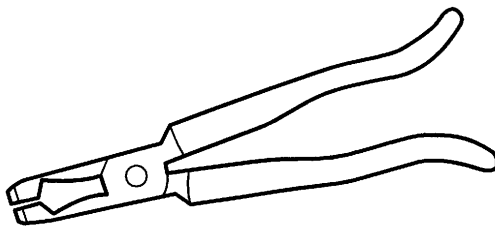
MKM-669**KM-726-A****KM-796-A****KM-834****KM-840**

L 6747

MKM-669 Torque Wrench, 1/2"
Range 50 – 300 Nm / 37 – 221 lb. ft.

KM-726-A Oil Filter Wrench
To remove/install the oil filter

KM-796-A Remover
To open quick fittings for fuel lines

KM-834-A Remover / Installer
To remove and install heat sleeves

KM-840 Remover
To remove valve stem seal

Special Tools and Equipment (Continued)

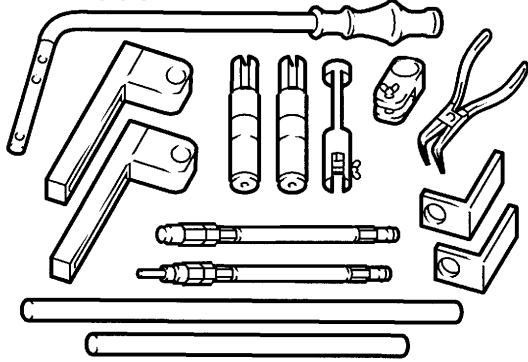
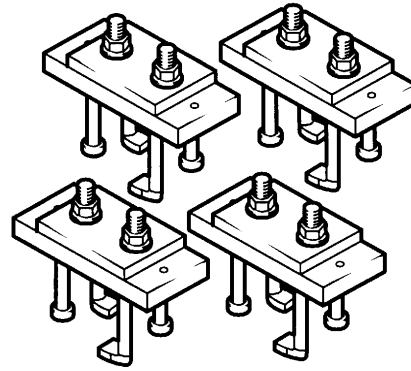
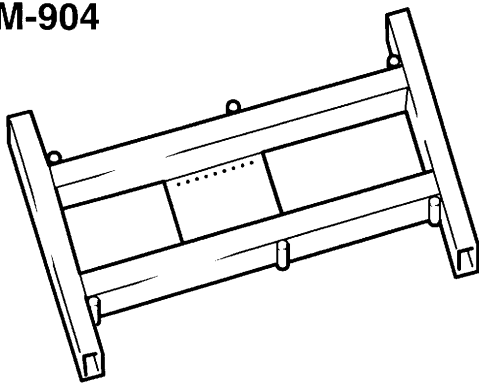
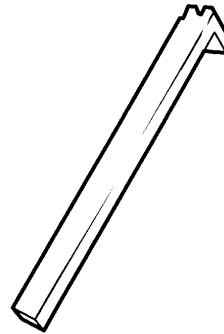
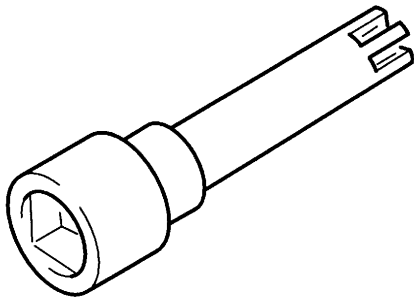
MKM-889**MKM-891****KM-904****KM-911****KM-2355**

L 4750

MKM-889 Automatic Valve Spring Lever

To remove/install the valve stem seals (cylinder head installed)

MKM-891 Valve Lifter Depressor

To lock flywheel/drive disc

MKM-891 Valve Lifter Depressor

To remove/install camshaft (cylinder head installed)

KM-2355 Socket Wrench T55

To loosen/tighten cylinder head bolts

KM-904 Base Frame

To remove and install various vehicle components with additional adapters

Special Tools and Equipment (Continued)

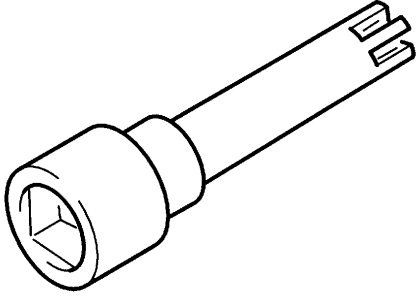
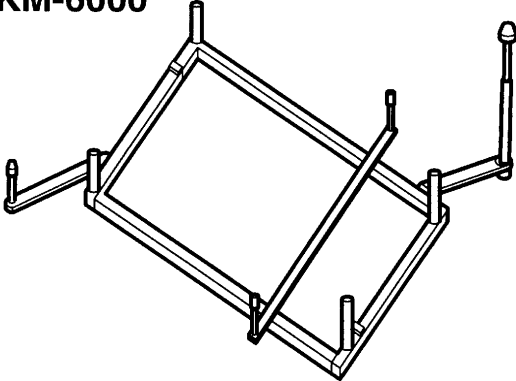
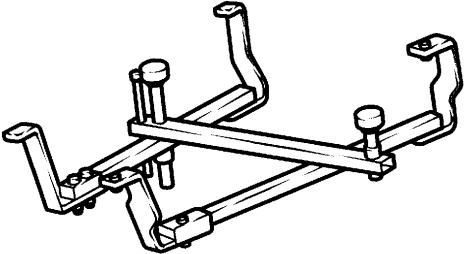
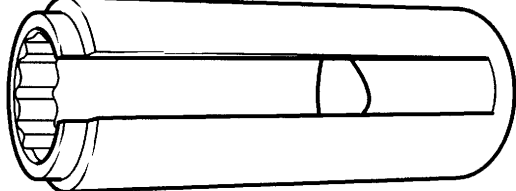
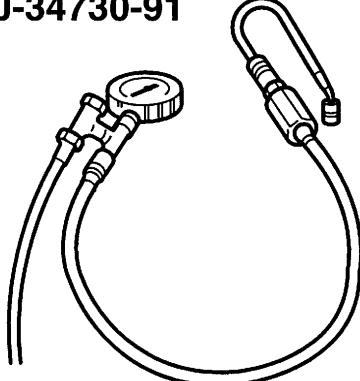
<p>KM-2355</p> 	<p>KM-6000</p> 
<p>KM-6001-A</p> 	<p>KM-6179</p> 
<p>KM-J-34730-91</p> 	<p style="text-align: right;">L 4749</p>

KM-6000 Centering Tool

To remove and install front axle in conjunction with KM-904

KM-6001-A Engine Mount

To align engine to body in conjunction with KM-6173

KM-6173 Engine Mount

To support engine on front axle body in conjunction with KM-6001-A

KM-6179 Remover / Installer

To remove and install oxygen sensor

KM-J-34730-91 Pressure Tester

To check fuel pressure

Section 2

Engine Cooling

Fastener Notice	2-2	Coolant Pipe and/or Hose Replacement	2-11
Specifications	2-3	Drive Belt Replacement	2-12
Fastener Tightening Specifications	2-3	Cooling Fan Replacement	2-12
Engine Cooling System Specifications	2-3	Fan Shroud Replacement	2-13
Diagnostic Information and Procedures	2-4	Fan Guard Replacement	2-14
Engine Overheating	2-4	Coolant Thermostat and/or Housing Replacement .	2-15
Loss of Coolant	2-5	Water Pump Replacement	2-16
Thermostat Diagnosis	2-5	Drain Cock Replacement	2-18
Engine Fails To Reach Normal Operating Temp	2-6	Radiator Replacement	2-18
Coolant Concentration Testing	2-7	Description and Operation	2-19
Cooling System Leak Testing	2-8	Cooling System Description	2-19
Repair Instructions	2-9	Radiator Assembly Description	2-19
Draining and Filling Cooling System	2-9	Pressure Cap Description	2-20
Cooling System Flushing	2-9	Water Pump Description	2-21
Cooling System Scale Removal	2-9	Thermostat Description	2-21
Radiator Hose Replacement	2-10	Special Tools and Equipment	2-21
Fuel Injection Coolant Hose Replacement	2-10		

Fastener Notice

NOTICE: Always use the correct fastener in the proper location. When you replace a fastener, use **ONLY** the exact part number of that application.

UNLESS OTHERWISE SPECIFIED, Do Not use supplemental coatings (paints, greases or other corrosion inhibitors) on threaded fasteners or fastener joint interfaces. Generally, such coating adversely affect the fastener torque and the joint clamping force, and may damage the fastener.

When you install fasteners, use the correct tightening sequence and specifications.

Following these instructions can help you avoid damage to parts and systems.

Engine Cooling - 1.6L

Specifications

Fastener Tightening Specifications

Application	N•m	lb ft	lb in
Coolant Temperature Sensor	20	14	
Drain Cock to Radiator	18	13	
Fan Blade to Pulley Bolts	15-18	10-13	
Fan Guard Mounting Bolts	16-20	12-15	12-15
Fan Housing Mounting Bolts	16-20	12-15	
All Hose Clamps	2.5		22
Radiator Mounting Bracket Bolts	25	18	
Water Pump to Engine Block Mounting Bolts	8	6	
Thermostat Housing to Cylinder Head Bolts	10	7	
Generator Upper Bracket Mounting Bolt	20	15	
Generator Lower Bracket Mounting Bolt	35	26	

Engine Cooling System Specifications

Application	Metric	English
1.6L (w/o radiator)	3.3 liters	3.5 quarts
1.6L (w/radiator)	9.5 liters	10 quarts

Diagnostic Information and Procedures

Engine Overheating

Step	Action	Value(s)	Yes	No
1	Check the coolant level. Is the coolant level low?	—	Go to Step 2	Go to Step 3
2	Add coolant to the system Does the engine still overheat?	—	Go to Step 3	System OK
3	Pressure test the system and check for visual leaks. Are there any external leaks in the system?	—	Go to Loss of Coolant.	Go to Step 4
4	Check the condition of the drive belt. Is the drive belt loose or unserviceable?	—	Adjust or replace the drive belt.	Go to Step 5
5	Check the hoses. Have the hoses collapsed?	—	Go to Step 6	Go to Step 7
6	Replace the hoses. Refer to Radiator Hose Replacement. Does the engine still overheat?	—	Go to Step 7	System OK
7	Check the temperature level of the thermostat. Is the temperature level high?	—	Go to Step 8	Go to Step 9
8	Replace the thermostat. Refer to Thermostat Replacement. Does the engine still overheat?	—	Go to Step 9	System OK
9	Check the radiator. Is the radiator clogged?	—	Go to Cooling System Flushing	Go to Step 10
10	Check the engine block. Is the engine block clogged?	—	Go to Cooling System Flushing	Go to Step 11
11	Check for bubbles in the coolant. Are there bubbles in the coolant?	—	Go to Step 12	Go to Step 13
12	Perform a Compression Test. Refer to Engine Mechanical Were results OK.	—	Go to Step 13	Go to Engine Mechanical
13	Check the water pump. Does coolant flow?	—	Go to Step 15	Go to Step 14
14	Replace the water pump. Refer to Water Pump Replacement. Does the engine still overheat?	—	Go to Step 15	System OK
15	Check the radiator fan. Is the radiator fan operating normally?	—	Go to Step 16	Go to Step 17
16	Check for any of the following conditions that may contribute to the engine overheating: <ul style="list-style-type: none"> • An overloaded condition • Excess engine oil • Blocked air flow through the radiator • Extreme air temperatures Does the engine still overheat?	—	—	System OK
17	Replace the radiator fan. Refer to Cooling Fan Replacement. Does the engine still overheat?	—	—	System OK

Loss of Coolant

Step	Action	Value(s)	Yes	No
1	Do a visual system check to look for a coolant loss. Check the ground under the equipment. Is there coolant on the ground?	—	Go to <i>Step 2</i>	—
2	Check the radiator for stains and wetness. Is the radiator wet or stained?	—	Go to <i>Step 3</i>	Go to <i>Step 4</i>
3	Repair or replace the radiator as necessary. Use any of the following procedures. Refer to <i>Radiator Replacement</i> . Is there still a loss of coolant?	—	Go to <i>Step 4</i>	System OK
4	Check the hoses for stains or wetness. Are the hoses stained or wet?	—	Go to <i>Step 5</i>	Go to <i>Step 6</i>
5	Repair or replace the hoses as necessary. Refer to <i>Radiator Hose Replacement</i> . Is there still a loss of coolant?	—	Go to <i>Step 6</i>	System OK
6	Check the water pump for stains or wetness. Is the water pump stained or wet?	—	Go to <i>Step 7</i>	Go to <i>Step 8</i>
7	Repair or replace the water pump. Use any of the following procedures: Refer to <i>Water Pump Replacement</i> . Is there still a loss of coolant?	—	Go to <i>Step 8</i>	System OK
8	Check the coolant recovery reservoir, if equipped. Does the coolant overflow after you stop the engine?	—	Go to <i>Step 9</i>	—
9	Check the radiator cap for pressure retention. Is the radiator cap retaining the proper pressure?	48 kPa (7 psi)	Go to <i>Step 10</i>	Go to <i>Step 11</i>
10	Check the temperature reading. Is the temperature too high?	—	Go to <i>Engine Overheating</i> .	Go to <i>Step 12</i>
11	Replace the radiator cap. Refer to <i>Pressure Cap Description</i> . Is there still a loss of coolant?	—	Go to <i>Step 12</i>	System OK
12	Check the coolant gravity for glycol concentration. Refer to <i>Coolant Concentration Testing</i> . Is the glycol concentration too low?	—	Go to <i>Step 13</i>	System OK
13	Replace the glycol. The recommended ethylene glycol mix 52/48 is normal up to a maximum of 60% glycol, 40% water. Is there still a loss of coolant?	—	—	System OK

Thermostat Diagnosis

Use the following procedure to check for engine overheating, boiling or poor engine cooling:

Hang the thermostat on a hook in order to perform an operational check of the thermostat. Hang the thermostat in a 33 percent glycol solution at 12°C (10°F) below the temperature indicated on the valve.

The valve will close when you submerge the valve and agitate the coolant.

Use the following procedure to check for engine overheating, boiling or poor engine cooling:

1. Relieve the pressure and carefully remove the radiator cap.
2. Rub a 96.6°C (206°F) temperature stick on the thermostat housing.
3. Warm up the engine at a fast idle. Watch for coolant flow before the mark begins to melt.
 - If the coolant does not flow, install a new thermostat. Recheck the system in order to ensure the system is operating properly.
 - If there is coolant flow, the problem is caused by something other than a faulty thermostat.

Thermostat Diagnosis (Cont'd)

Use the following procedure in order to check for a cold engine, slow warm-up or the engine does not reach normal operating temperature of 86.6°C (188°F) to 96.6°C (206°F):

1. Relieve the pressure and carefully remove the radiator cap.
2. Rub a 86.6°C (188°F) temperature stick on the thermostat housing.
3. Warm up the engine at a fast idle. Watch for coolant flow before the mark begins to melt.
 - If the coolant flows, before the mark begins to melt, install a new thermostat. Recheck the system in order to ensure the system is operating properly.
 - If there is coolant flow after the mark begins to melt, the problem is caused by something other than a faulty thermostat.

A temperature stick is a pencil like device that has a wax material containing certain chemicals. These chemicals melt at a certain temperature. Use a temperature stick in order to determine a thermostat's operating temperature by rubbing the 86.6°C (188°F) and the 96.6°C (206°F) sticks on the thermostat housing. The marks made by the sticks should melt when the coolant temperatures of 86.6°C (188°F) to 96.6°C (206°F) are reached. These temperatures are the normal operating range of the thermostat. If the coolant flows as indicated in the preceding procedures, the thermostat is considered to be operating properly.

Engine Fails to Reach Normal Operating Temperature

Step	Action	Value(s)	Yes	No
DEFINITION: The engine fails to reach the normal operating temperature of 86.6°C (188°F) to 96.6°C (206°F).				
1	Check the thermostat. Is the thermostat stuck open or was the wrong type of thermostat previously installed?	—	Go to Step 2	—
2	Replace the thermostat. Is the problem corrected?	—	System OK	—

Coolant Concentration Testing

Hydrometer

Due to changes in commercially available antifreeze, the use of a hydrometer may give an incorrect reading. The hydrometer should be used to test an ethylene glycol-based antifreeze only. Ethylene glycol-based antifreeze is recommended for year round use.

Coolant Tester

Use the coolant testers *J 26568* with the Centigrade scale or *J 23688* with the Fahrenheit scale in order to check the antifreeze protection of the coolant. Make sure that the hydrometer markings are correct. Unless *J 26568* or *J 23688* has a provision for temperature correction, test the temperature at which the coolant testers are calibrated. If the coolant is warmer or colder, the reading may be incorrect. Follow the manufacturer's directions in order to use the *J 26568* or the *J 23688*.

Clean the coolant tester before each use with the following procedure:

1. Swing back the plastic cover at the slanted end of the tester in order to expose the measuring window and the bottom of the plastic cover.

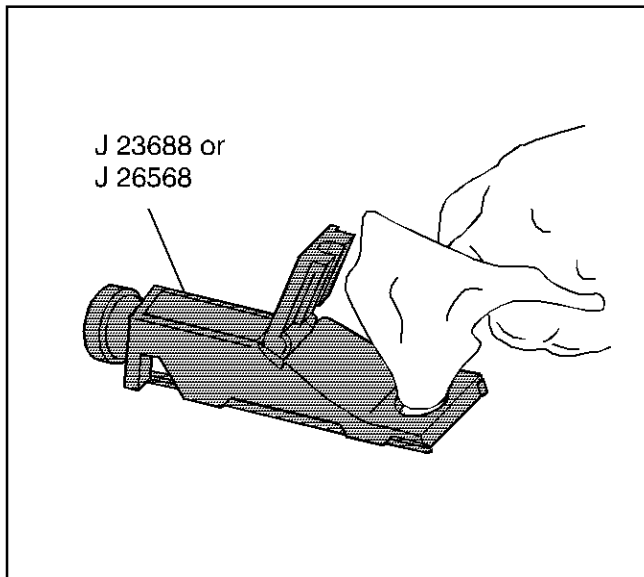

13712

2. Wipe the coolant tester dry with a tissue or a clean soft cloth.
3. Close the plastic cover.

Testing

Do not remove the clear plastic pump from the tester. Use the following procedure to test the coolant:

1. Release the tip of the pump from the tester housing.

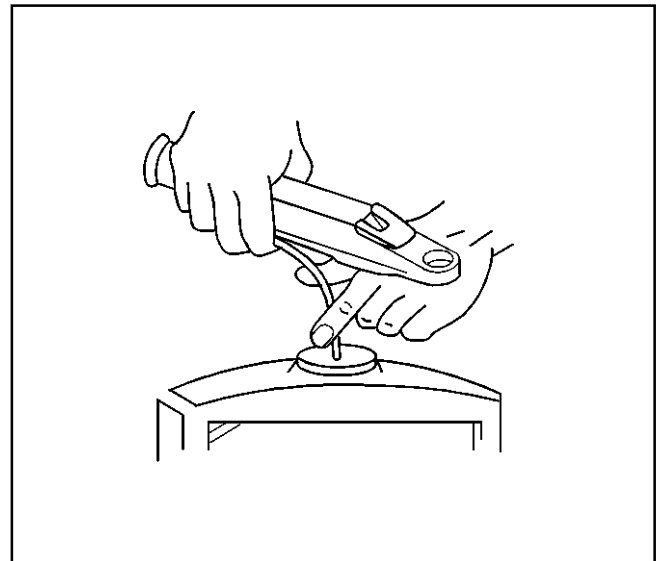

13709

2. Insert the tip into the radiator filler neck. Insert the tip below the level of the coolant.
3. Press and release the bulb in order to draw a sample.
4. Bend the plastic tube around and insert the tip into the cover plate opening.
5. Press the bulb and inject a few drops of the coolant into the measuring surface. Do not open the plastic cover when you take the readings because water evaporation may change the reading.

Reading the Tester

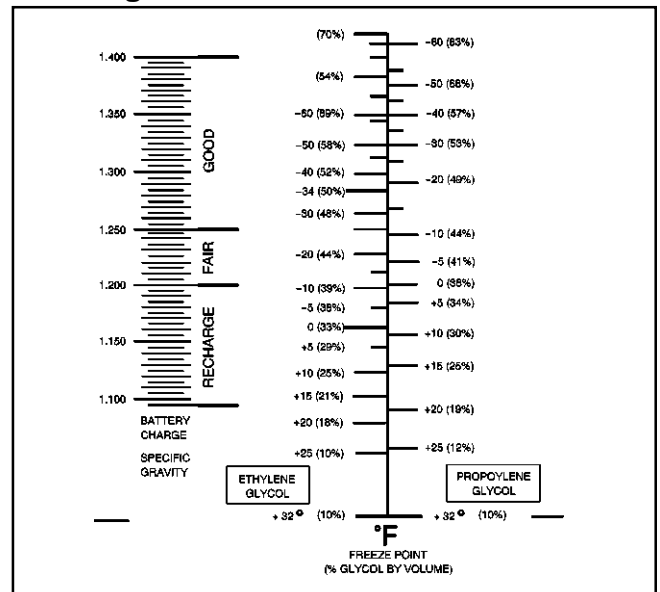

13713

- Point the tester toward any light source and look into the eyepiece.
- The antifreeze protection reading is at the point where the dividing line between the light and the dark edge of the shadow crosses the scale. The antifreeze protection is the right scale and the battery charge is on the left.

- The tester temperature scale is reversed from the standard thermometer scale in that below zero readings are on the upper half of the scale. Readings on the lower half of the scale, which are the above zero readings, indicate solutions without enough antifreeze concentration to provide adequate rust protection.
- Tilt the tester toward the light source in order to obtain the best results. If the edge of the shadow is not defined, the measuring surfaces are not clean or dry. Wipe the tester dry and retest the coolant.

Cooling System Leak Testing

Notice: Pressure above 139 kPa (20 psi) should not be used when pressure testing the cooling system. Pressures over 138 kPa (20) psi will damage the radiator.

Some core leaks are detected by adding water to the radiator. Clean the core using the following procedure so that the damaged area can be found:

1. Remove the dirt and the insects from the fins with a common water hose that does not have a nozzle. Excessive water pressure could damage the fins.
2. Scrub the core with a soft-bristle brush using clean hot water or hot water with a mild detergent.

On-Equipment Pressure Testing

Tools Required

J24460-01 Radiator Pressure Tester

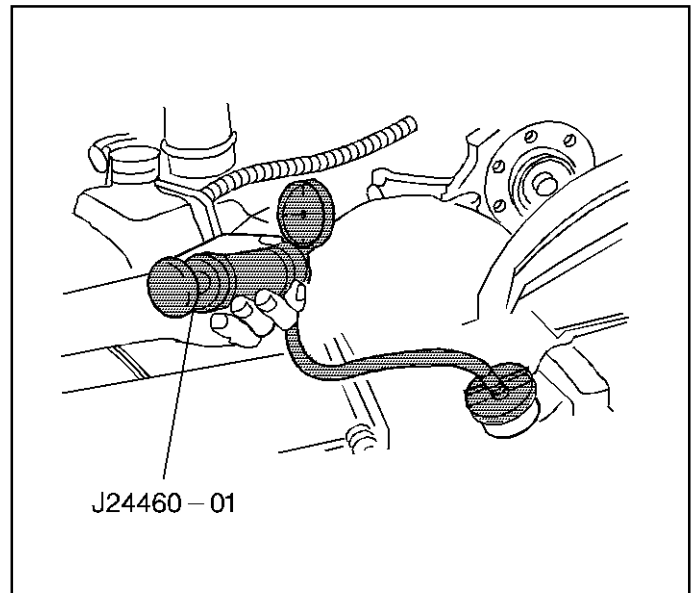

11658

Pressure-test the radiator with the *J24460-01*. While the system is at a cool temperature, remove the radiator cap. Connect the gauge and apply the normal system operating pressure. Do not exceed 138 kPa (20 psi). Watch the gauge needle for an indication of a leak. Examine the radiator and other cooling system parts for escaping coolant.

Repair the hose and the hose connections as required.

Check the radiator cap in order to ensure that the cap will maintain the correct pressure.

If the radiator leaks during the pressure test, mark the leak area.

Repair Instructions

Draining and Filling Cooling System

Draining Procedure

Caution: *The radiator cap should be removed from a cool engine only. If the radiator cap is removed from a hot cooling system, serious personal injury may result.*

Caution: *As long as there is pressure in the cooling system, the temperature can be considerably higher than the boiling temperature of the solution in the radiator, without causing the solution to boil. Removal of the radiator cap while the engine is hot and the pressure is high will cause the solution to boil instantaneously and possibly with explosive force, spewing the solution over the engine, body, and person removing the cap. Under some conditions, the engine coolant is combustible.*

Use the following procedure in order to drain the cooling system:

1. Place a drain pan under the radiator drain cock.
2. Install a tube on the drain cock.
3. Place the end of the tube in the drain pan.
4. Ensure the cooling system is cool. Remove the radiator cap.
5. Open the drain cock completely.
6. Allow the cooling system to drain until the flow stops.
7. Place a drain pan under the engine.
8. Remove the drain plug from the engine block.
9. Allow the engine block to drain until the flow stops. There may be some more drainage from the radiator at this time.
10. Replace the engine block drain plug.
11. Close the radiator drain cock.

Refilling Procedure

NOTICE: *When refilling the engine cooling system, ensure that the level is kept approximately 13 mm (1/2 in) below the fill line. This will help vent an air lock from occurring in the system.*

Monitor the engine closely on initial start up to make sure the thermostat opens properly, allowing coolant to recirculate. If the thermostat does not open, an air lock may be present. In this instance it will be necessary to install a bleed valve in a high point in the system. Run the engine with the bleed valve installed and open. Continue running until all air is purged from the system and coolant is coming out of the bleed valve.

Use the following procedure to refill the cooling system:

1. Check the radiator drain cock to ensure that it is closed.

2. Check the engine drain plug in order to ensure that the drain plug is closed.
3. Place a large funnel in the radiator fill hole.
4. Fill the system with ethylene glycol based coolant to the radiator. Do not pre-mix the coolant and water. Fill the remainder of the radiator with clean drinkable water in order to equal a 52/48 mix. Refer to *Engine Cooling System Specifications* for the cooling system capacity. The filling may be slowed due to the thermostat being closed.
5. Fill the cooling system to 13 mm (1/2 in) below the fill line.
6. Start the engine and allow the cooling system to warm up. When the thermostat opens, the coolant level may drop. If the level drops, add coolant until the level is up to the top.
7. Replace the radiator cap.
8. Check the coolant level in the radiator surge tank, if equipped. Add coolant as needed.

Flushing

Notice: *If the engine is damaged internally and a new engine assembly is installed, make sure all foreign material is completely flushed out of the cooling system. The oil cooler system should also be flushed out. Failure to rid the oil or cooling system of debris can result in damage to the replacement engine.*

Important: *Remove the thermostat before you flush the cooling system.*

Various methods and equipment can be used in order to flush the cooling system. If you use special equipment such as a back flusher, follow the equipment manufacturer's instructions.

Cooling System Scale Removal

In order to remove hardened scale, a direct chemical action is necessary. Add a flushing compound in a dissolved solution at the specified rate of 30 grams per liter (4 oz. per gallon) of radiator capacity to the coolant water. Do this while the water is running. Operate the engine for 15 minutes. Then, drain and flush the system with clean water.

There are various types of flushing compounds available commercially. Obtain the compounds from a reliable source. Most compounds attack metals and should not remain in the engine block for more than a few minutes. Use a neutralizer in the cooling system immediately after you use a descaling solvent.

Use a stronger solution for extremely hard, stubborn coatings, such as lime scale. The corrosive action of a stronger solution affects the thin metals of the radiator, which reduces the operating life of the radiator. A complete flush and rinse of the radiator is mandatory and must be accomplished skillfully. Drain the entire system after the solvent and neutralizer are used and the cooling system is flushed. Fill the system with a 48/52 mixture of distilled water and an ethylene glycol-based coolant. Check for coolant leaks in the radiator, the hose and the engine.

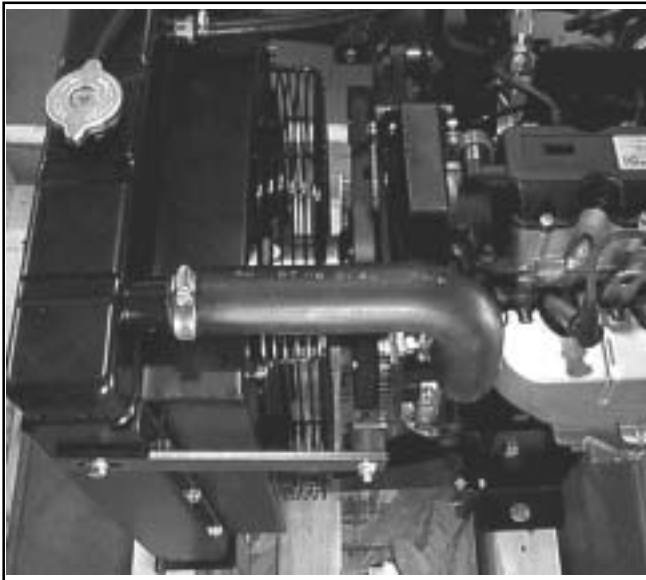

80362002



80362003

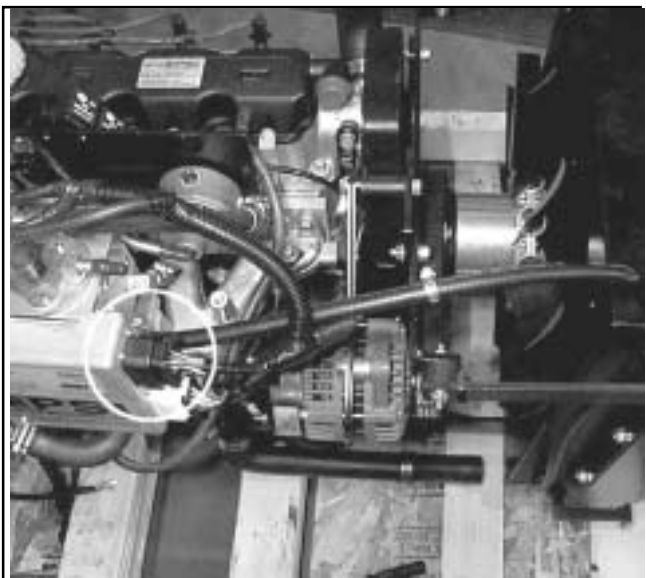

80362005

Radiator Hose Replacement

Removal Procedure

1. Drain the coolant from the radiator so that the level of the coolant is below the hose that is being removed.
2. Remove the radiator hose clamps.
3. Remove the upper radiator hose from the radiator and the coolant thermostat housing.
4. Remove the lower radiator hose from the radiator and the coolant pipe.

Installation Procedure

1. Install the lower radiator hose to the radiator and to the coolant pipe.
2. Install the upper radiator hose to the radiator and the coolant thermostat housing.

Notice: Refer to *Fastener Notice*.

3. Install the radiator hose clamps.

Tighten

Tighten the radiator hose clamps to 2.5 N•m (22 lb in).

4. Add the coolant to the proper level. Refer to *Draining and Filling Cooling System*.
5. Start the engine and check for leaks.

Fuel Injection Coolant Hose Replacement

Removal Procedure

1. Drain the coolant from the radiator so that the level of the coolant is below the hose.
2. Remove the radiator hose clamps.
3. Remove the fuel injection coolant hose from the radiator and the fuel injection unit.

Installation Procedure

1. Install the fuel injection coolant hose to the radiator and the fuel injection unit.

Notice: Refer to *Fastener Notice*.

2. Install the hose clamps.

Tighten

Tighten the hose clamps to 2.5 N•m (22 lb in).

3. Add the coolant to the proper level. Refer to *Draining and Filling Cooling System*.
4. Start the engine and check for leaks.

Coolant Pipe and/or Hose Replacement

Removal Procedure

1. Drain the coolant from the radiator so that the level of the coolant is below the hose that is being removed.
2. Remove the radiator hose clamps.
3. Remove the lower radiator hose from the coolant pipe.
4. Remove the coolant pipe from the coolant hose.
5. Remove the coolant hose from the engine block.

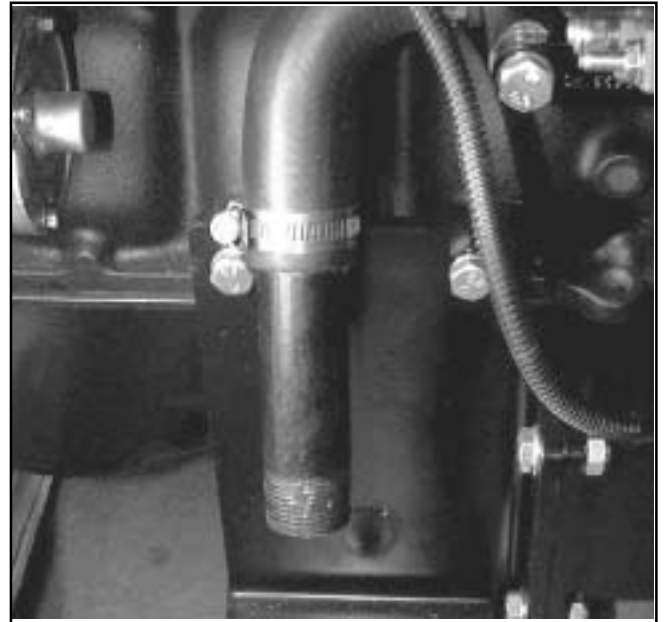

80362004

Installation Procedure

1. Install the coolant hose to the engine block.
2. Install the coolant pipe to the coolant hose.
3. Install the lower radiator hose to the coolant pipe.

Notice: Refer to *Fastener Notice*.

4. Install the radiator hose clamps.

Tighten

Tighten the radiator hose clamps to 2.5 N•m (22 lb in).

5. Add the coolant to the proper level. Refer to *Draining and Filling Cooling System*.
6. Start the engine and check for leaks.

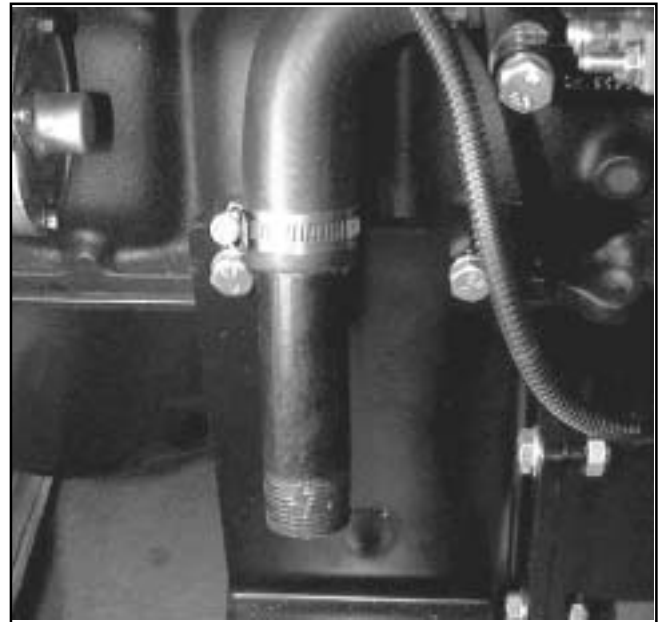

80362004

Drive Belt Replacement

Removal Procedure

1. Remove the fan guard. Refer to *Fan Guard Replacement*.
2. Loosen the generator mounting bolts.
3. Move the generator inward to loosen the tension on the drive belt.
4. Slide the belt off of the pulleys and over the fan blades.
5. Inspect the drive belt for:
 - Cracks
 - Glazing
 - Tears or cuts
 - Hardening
 - Excessive wear

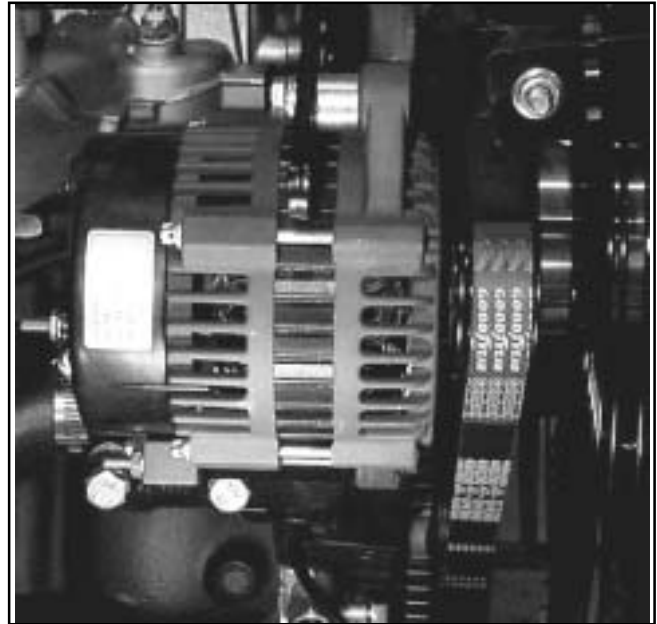

80362001

Installation Procedure

Tools Required:

- 6" Steel Rule
1. Slide the belt over the fan blades and route it over the pulleys.
 2. Move the generator outward until the fan belt measures approximately 1/2-inch (13 mm) deflection.

Notice: Refer to *Fastener Notice*.

3. While maintaining tension on the drive belt, tighten the generator mounting bolts.

Tighten

Tighten the lower generator mounting bolt to 35 N•m (26 lb ft).

Tighten the upper generator mounting bolt to 20 N•m (15 lb ft).

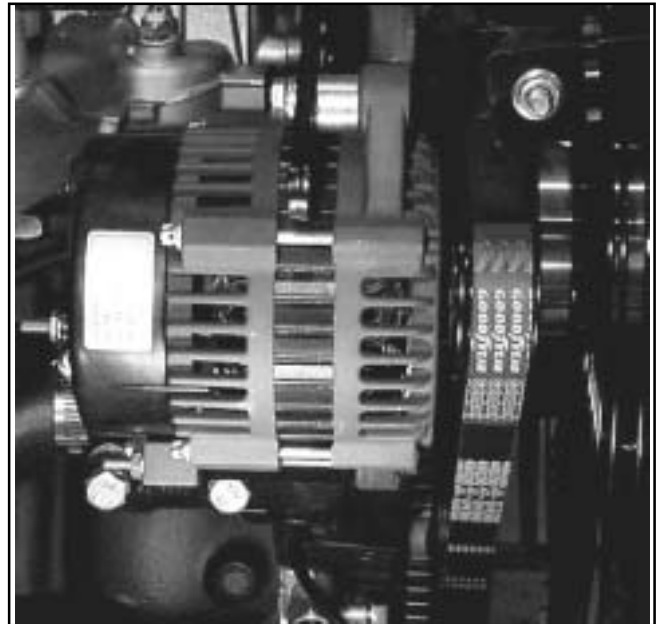

80362001

Cooling Fan Replacement

Removal Procedure

1. Remove the fan guard. Refer to *Fan Guard Replacement*.
2. Drain the cooling system. Refer to *Draining and Filling Cooling System*.
3. Remove the upper radiator hose from the radiator. Refer to *Radiator Hose Replacement*.
4. Remove the upper radiator hose from the radiator.
5. Remove the radiator upper support at the radiator. Refer to *Radiator Replacement*.
6. Remove the Drive belt. Refer to *Drive Belt Replacement*.
7. Tilt the radiator forward.

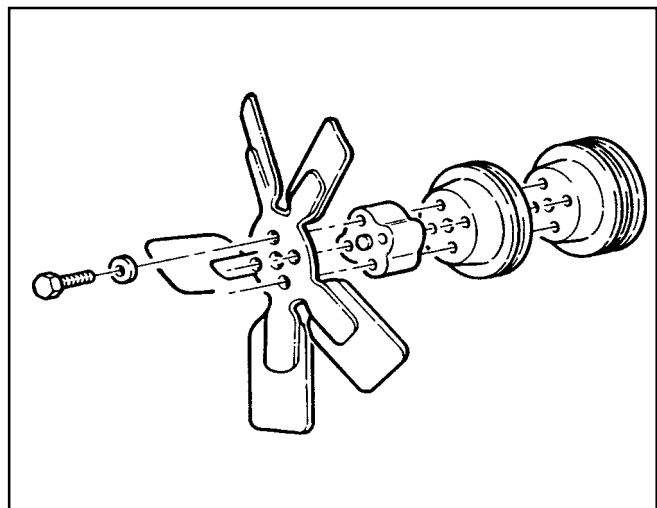

79362002

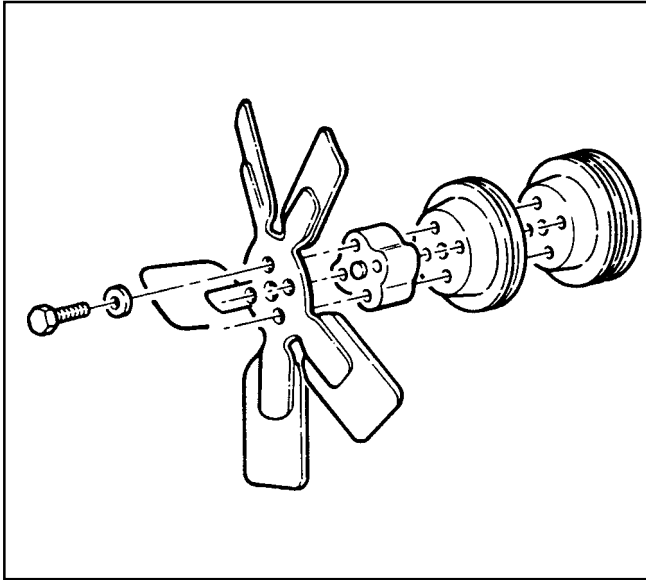

79362002

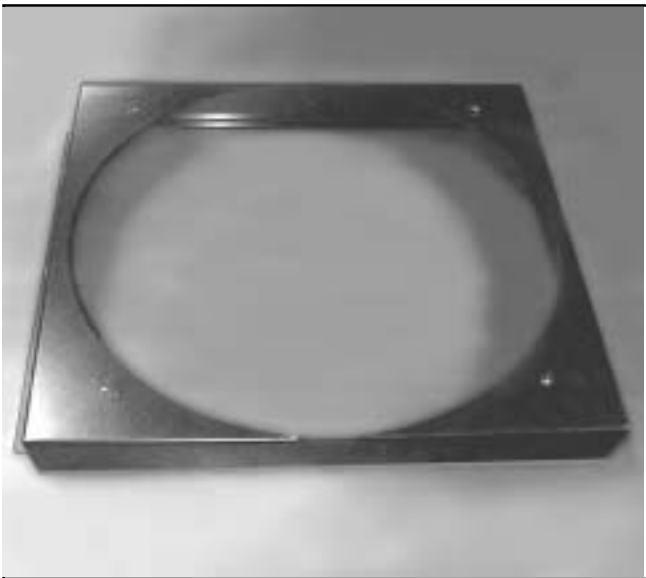

79362003

8. Remove the fan blade mounting bolts and washers.
9. Remove the fan, pulley and spacer, if equipped.

Installation Procedure

1. Position fan, pulley, and spacer, if equipped, onto the water pump shaft.

Notice: Refer to *Fastener Notice*.

2. Install the fan blade mounting bolts and washers.

Tighten

Tighten the fan blade mounting bolts to 15-18 N•m (10-13 lb ft).

3. Install the Drive belt. Refer to *Drive Belt Replacement*.
4. Install the radiator upper support bolts.

Tighten

Tighten the radiator upper support bracket mounting bolts to 25 N•m (18 lb ft).

5. Install the fan guard. Refer to *Fan Guard Replacement*.
6. Connect the upper radiator hose to the radiator. Refer to *Radiator Hose Replacement*.
7. Connect the fuel injection coolant hose to the radiator.

Tighten

Tighten the fuel injection coolant hose clamp to 2.5 N•m (22 lb in).

8. Fill the cooling system. Refer to *Draining and Filling Cooling System*.

Fan Shroud Replacement

Removal Procedure

1. Remove the fan guard. Refer to *Fan Guard Replacement*.
2. Disconnect the radiator overflow hose clamps from the fan shroud.
3. Remove the fan shroud mounting bolts and washers.
4. Remove the radiator upper support brackets at the radiator.
5. Tilt the radiator forward and remove the fan shroud.

Installation Procedure

1. Tilt the radiator forward and position the fan shroud over the cooling fan blades.

Notice: Refer to *Fastener Notice*.

2. Install the fan shroud mounting bolts and washers.

Tighten

Tighten the fan shroud mounting bolts to 16-20 N•m (12-15 lb ft).

Notice: Refer to *Fastener Notice*.

3. Install the radiator upper support brackets to the radiator.

Tighten

Tighten the radiator upper support bracket mounting bolts to 25 N•m (18 lb ft).

4. Install the fan guard. Refer to *Fan Guard Replacement*.
5. Connect the radiator overflow hose clamps to the fan shroud.

Fan Guard Replacement**Removal Procedure**

1. Disconnect the upper radiator hose from the radiator. Refer to *Radiator Hose Replacement*.
2. Disconnect the fuel injection coolant hose from the radiator.
3. Remove the fan guard mounting bolts and washers.

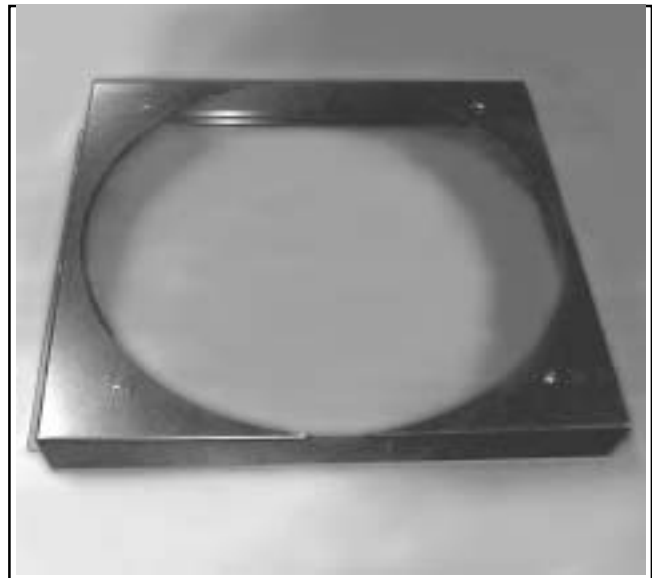

79362003

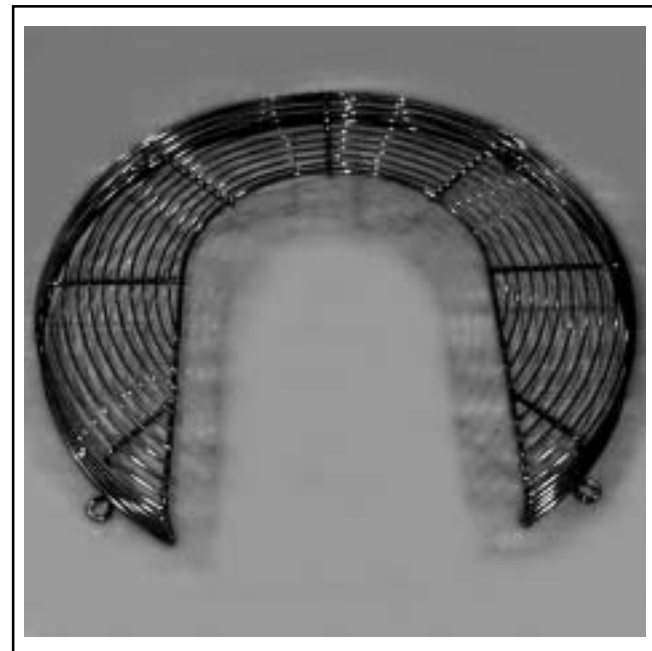

79362004

Installation Procedure

1. Position the fan guard over the cooling fan blades.

Notice: Refer to *Fastener Notice*.

2. Install the fan guard mounting bolts and washers.

Tighten

Tighten the fan guard mounting bolts to 16-20 N•m (12-15 lb ft).

3. Connect the upper radiator hose to the radiator. Refer to *Radiator Hose Replacement*.
4. Connect the fuel injection coolant hose to the radiator.
5. Fill the cooling system. Refer to *Draining and Filling Cooling System*.

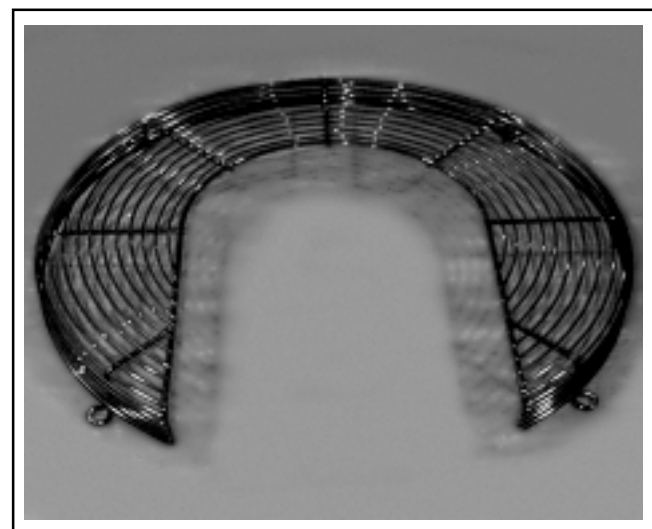

79362004

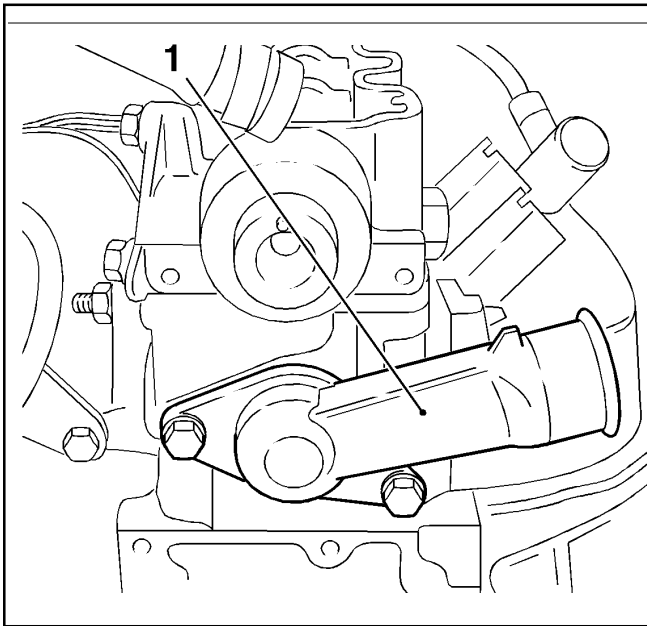

79362008

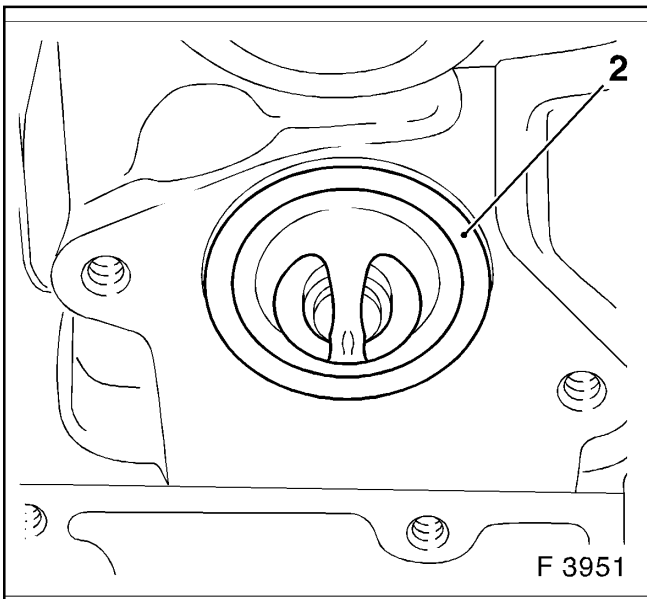

F 3951

79362009

Coolant Thermostat and/or Housing Replacement

Removal Procedure

1. Drain the cooling system. Refer to *Draining and Filling Cooling System*.
2. Remove the upper radiator hose from the thermostat housing. Refer to *Radiator Hose Replacement*.
3. Remove the radiator upper support. Refer to *Radiator Replacement*.
4. Remove the drive belt. Refer to *Drive Belt Replacement*.
5. Remove the generator upper support bracket. Refer to *Section 3, Engine Electrical*.
6. Remove the upper and lower toothed belt covers. Refer to *Section 1, Engine Mechanical*.
7. Remove the toothed belt. Refer to *Section 1, Engine Mechanical*.
8. Remove the toothed belt tension roller. Refer to *Section 1, Engine Mechanical*.
9. Remove the toothed belt rear cover. Refer to *Section 1, Engine Mechanical*.
10. Remove the two thermostat housing bolts.
11. Remove the coolant thermostat housing (1).
12. Remove the coolant thermostat (2) and seal ring.
13. Discard the seal ring.
14. Clean and inspect all sealing surfaces.

Installation Procedure

1. Install the coolant thermostat (2), coolant thermostat housing (1), and a new seal ring onto the cylinder head.

Notice: Refer to *Fastener Notice*.

2. Install the two coolant thermostat housing bolts.

Tighten

Tighten the thermostat housing bolts to 10 N•m (7 lb ft).

3. Install the toothed belt rear cover. Refer to *Section 1, Engine Mechanical*.
4. Install the toothed belt tension roller. Refer to *Section 1, Engine Mechanical*.
5. Install the toothed belt. Refer to *Section 1, Engine Mechanical*.
6. Install the upper and lower toothed belt covers. Refer to *Section 1, Engine Mechanical*.
7. Install the generator upper support bracket. Refer to *Section 3, Engine Electrical*.
8. Install the drive belt. Refer to *Drive Belt Replacement*.

9. Install the radiator upper support. Refer to *Radiator Replacement*.
10. Connect the upper radiator hose to the coolant thermostat housing (1). Refer to *Radiator Hose Replacement*.
11. Fill the cooling system. Refer to *Draining and Filling Cooling System*.
12. Start the engine and Check for leaks.

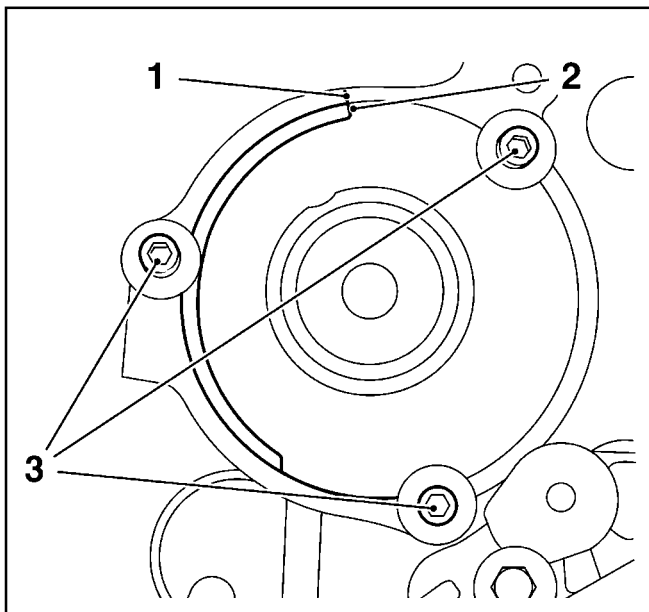

80362010

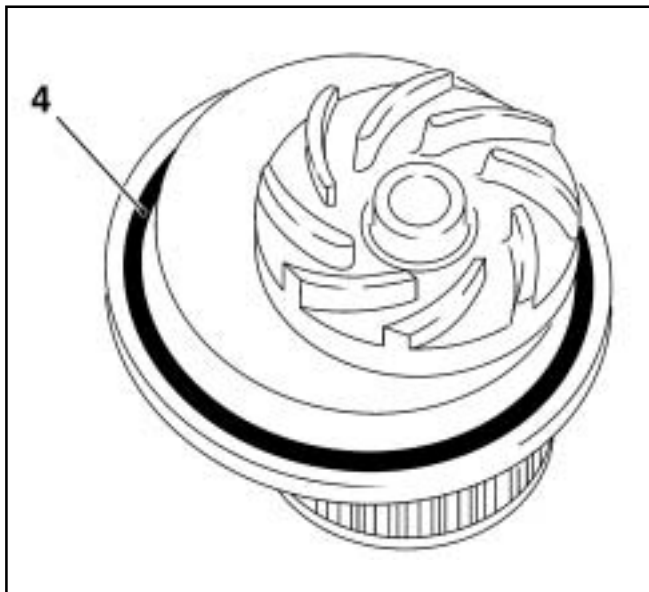

80362011

Water Pump Replacement

Removal Procedure

1. Drain the cooling system. Refer to *Draining and Filling Cooling System*.
2. Remove the radiator upper support. Refer to *Radiator Replacement*.
3. Remove the drive belt. Refer to *Drive Belt Replacement*.
4. Remove the fan guard. Refer to *Fan Guard Replacement*.
5. Remove the cooling fan. Refer to *Cooling Fan Replacement*.
6. Remove the generator upper support bracket. Refer to *Section 3, Engine Electrical*.
7. Remove the upper and lower toothed belt covers. Refer to *Section 1, Engine Mechanical*.
8. Remove the toothed belt. Refer to *Section 1, Engine Mechanical*.
9. Remove the toothed belt tension roller. Refer to *Section 1, Engine Mechanical*.
10. Remove the toothed belt rear cover. Refer to *Section 1, Engine Mechanical*.
11. Remove the water pump bolts (3) and washers.
12. Remove the water pump and sealing ring.
13. Discard the water pump sealing ring (4).
14. Inspect the water pump for the following:
 - Sealing surfaces for excessive scratches or gouges.
 - Excessive side-to-side play in the pulley shaft.
 - Leakage at the water pump vent hole.
 A stain around the vent hole is acceptable. If leakage occurs at the vent hole with the engine running and the cooling system pressurized, replace the pump.

Installation Procedure

1. Coat the sealing surfaces of the water pump with silicon (white) grease.

Important: When installing the water pump, align the mark on the cylinder block (1) with the mark on the water pump (2).

2. Position the water pump and a new sealing ring (4) to the engine block.

Notice: Refer to *Fastener Notice*.

3. Install the water pump bolts (3) and washers.

Tighten

Tighten the water pump bolts to 8 N•m (6 lb ft).

4. Install the toothed belt rear cover. Refer to *Section 1, Engine Mechanical*.
5. Install the toothed belt tension roller. Refer to *Section 1, Engine Mechanical*.
6. Install the toothed belt. Refer to *Section 1, Engine Mechanical*.
7. Install the upper and lower toothed belt covers. Refer to *Section 1, Engine Mechanical*.
8. Install the generator upper support bracket. Refer to *Section 3, Engine Electrical*.
9. Install the cooling fan. Refer to *Cooling Fan Replacement*.
10. Install the fan guard. Refer to *Fan Guard Replacement*.
11. Install the drive belt. Refer to *Drive Belt Replacement*.
12. Install the radiator upper support. Refer to *Radiator Replacement*.
13. Fill the cooling system. Refer to *Draining and Filling Cooling System*.
14. Start the engine and Check for leaks.

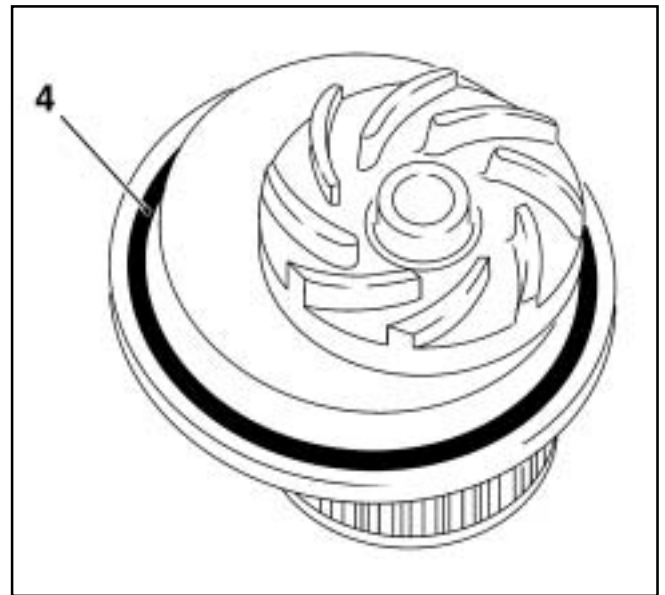

80362011

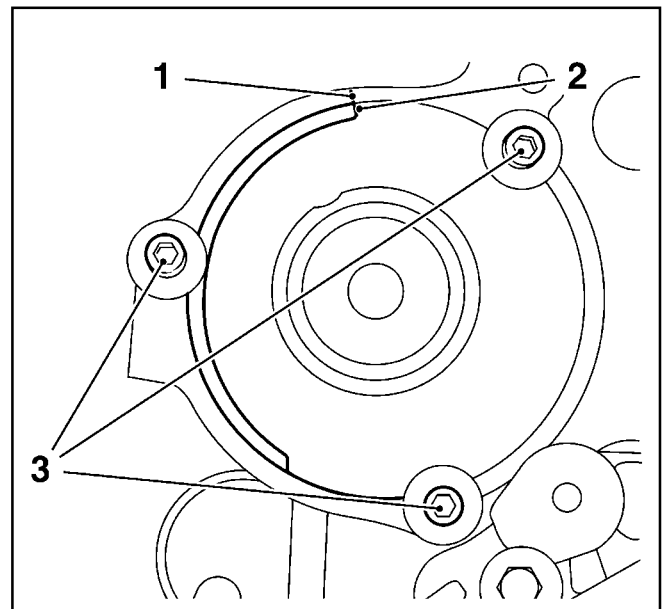

80362010

Drain Cock Replacement

Removal Procedure

1. Drain the cooling system. Refer to *Draining and Filling Cooling System*.
2. Remove the drain cock from the radiator.

Installation Procedure

Notice: Refer to *Fastener Notice*.

1. Install the drain cock to the radiator.

Tighten

Tighten the drain cock to 18 N•m (13 lb ft).

2. Fill the cooling system. Refer to *Draining and Filling Cooling System*.
3. Start the engine and check for leaks.



79362010

Radiator Replacement

Removal Procedure

1. Drain the cooling system. Refer to *Draining and Filling Cooling System*.
2. Disconnect the radiator hoses from the radiator. Refer to *Radiator Hose Replacement*.
3. Disconnect the fuel injection coolant hose.
4. Remove the fan guard. Refer to *Fan Guard Replacement*.
5. Remove the upper radiator bracket and mounting bolts.
6. Remove the lower radiator mounting bolts.
7. Remove the radiator.
8. Remove the fan shroud. Refer to *Fan Shroud Replacement*.



80362006

Installation Procedure

1. Install the fan shroud. Refer to *Fan Shroud Replacement*.
2. Position the radiator on the equipment.

Notice: Refer to *Fastener Notice*.

3. Install the lower radiator mounting bolts finger tight.
4. Install the radiator upper brackets and mounting bolts.

Tighten

Tighten all radiator mounting bolts to 25 N•m (18 lb ft).

5. Install the fan guard. Refer to *Fan Guard Replacement*.
6. Connect the radiator hoses to the radiator. Refer to *Radiator Hose Replacement*.
7. Connect the fuel injection coolant hose to the radiator.
8. Fill the cooling system. Refer to *Draining and Filling Cooling System*.
9. Start the engine and check for leaks.



80362006

Description and Operation

Cooling System Description

Cooling System

This equipment has a pressure-type engine cooling system. The system has thermostatic control of the coolant circulation. The cooling system is sealed by a pressure type radiator cap. The cap causes the system to operate at a pressure higher than atmospheric pressure. The high-pressure operation raises the boiling point of the coolant, which increases the cooling efficiency of the radiator. The 104 kPa (15 psi) pressure cap raises the boiling point of the coolant to about 125°C (257°F) at sea level.

Engine Coolant

Always fill the system with ethylene glycol based coolant to the radiator. Do not pre-mix the coolant and water. Fill the remainder of the radiator with clean drinkable water in order to equal a 52/48 mix. Refer to the mixture chart on the container for additional anti-freeze protection information. DO NOT use alcohol or methanol based antifreeze, or mix them with the specified coolant.

Notice: Antifreeze can be added to raise the boiling point of the coolant, but too much will affect the freezing point. Do not use a solution stronger than 60 percent glycol, 40 percent water as the freeze level rises rapidly after this point. Pure antifreeze will freeze at *22°C (*8°F).

* Approximate values.

Uncommon Cooling System Problems

The following problems do not require disassembly of the cooling system:

- Large obstructions block the radiator.
- Ice, mud or snow obstructs the radiator
- The engine oil is overfilled.
- Incorrect ignition timing

The following problems do require disassembly of the cooling system:

- An incorrect or damaged fan
- Incorrect radiator for the application
- Incorrect or faulty radiator pressure cap
- Check the specifications for the correct part numbers.
- Pressure check the cooling system while the pressure cap is installed. This shows if the pressure cap leaks due to radiator filler neck damage.
- Worn or damaged water pump
 - The impeller vanes are eroded or broken.
 - The bearing or the seal is worn or damaged.
 Check the shaft for bearing play.
- Plugged radiator tubes. Perform a flow check.

- Internal system leaks.
 - The cylinder head gasket
 - The cracked block
 - The timing chain cover
 - The intake manifold gasket
- Plugged coolant passages in the cylinder heads. Do a visual check.

Radiator Assembly Description

The radiator assembly is a downflow tube type utilizing an aluminum core with brass upper and lower tanks.

It is fitted with a shroud designed to assist the cooling fan in directing airflow through the radiator cores and also serves as a fan guard.

An additional fan guard is also installed to protect personnel from injury.

Pressure is maintained in the system by a pressure cap. The pressure cap has two valves: one which relieves pressure, and the other to compensate for coolant contraction when the engine is off. The radiator cap on this system has a 48kPa (7 psi) rating.

Radiator Maintenance

Radiators need special attention to prevent leakage and airflow restrictions. Check the outside of the radiator for bent fins or leakage. Leaking radiator cores should be repaired immediately, not just sealed temporarily with a sealer-type antifreeze or coolant additive.

Remove the radiator cap and look for plugging and scale on the inside of the tank. A badly plugged radiator may have to be replaced. If scale is found, remove it. *Refer to Cooling System Scale Removal.*

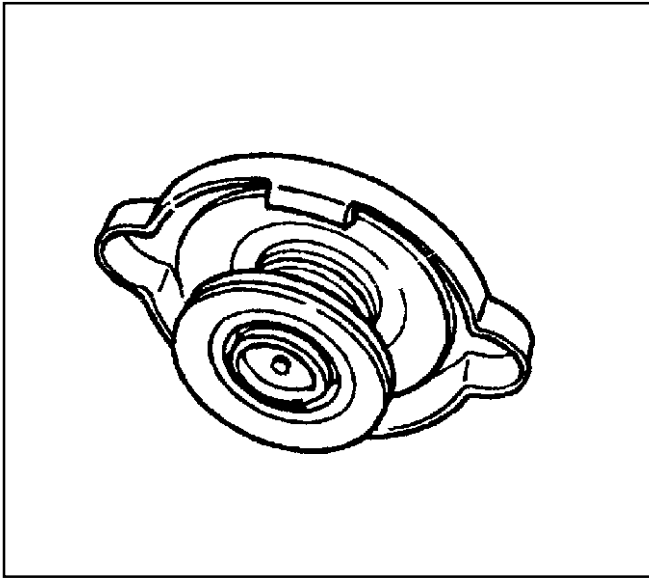

107487

Pressure Cap Description

Radiator Cap

Caution: As long as there is pressure in the cooling system, the temperature can be considerably higher than the boiling temperature of the solution in the radiator, without causing the solution to boil. Removal of the radiator cap while the engine is hot and the pressure is high will cause the solution to boil instantaneously and possibly with explosive force, spewing the solution over the engine, the equipment, and person removing the cap.

The pressure-vent radiator cap allows a buildup of 48 kPa (7 psi) in the cooling system. Do not remove the radiator cap to check the engine coolant level until the engine is cool. Add coolant to the radiator only after the system cools.

The radiator cap contains a blow-off or pressure valve. The cap also contains a vacuum or atmospheric valve. The pressure valve is held against its seat by a spring of predetermined strength. This valve protects the radiator by relieving internal pressure when the internal pressure exceeds the cooling system design limits. The vacuum valve is held against its cap seat by a light spring. The spring permits the valve to open in order to relieve vacuum created in the system when the system cools.

The radiator cap is designed to discourage inadvertent removal. In order to safely remove the cap from the radiator, rotate the cap slowly in a counterclockwise direction to the detent. Do not press down. Allow any pressure to release from the radiator. Press down on the cap. Continue to rotate the cap counterclockwise and lift the cap off the radiator.

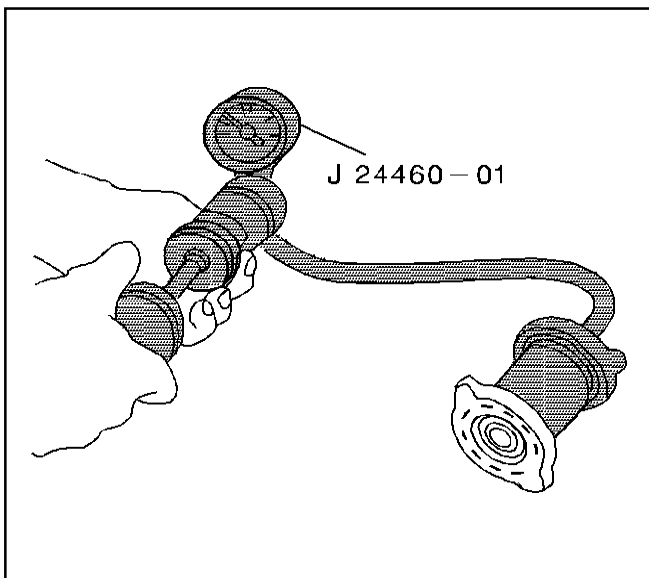

1375

Radiator Cap Inspection

Check the seal of the filler cap and the operation of the pressure valve with a conventional cooling system

Water Pump Description

The die-cast pump is a centrifugal vane impeller type. The impeller turns on a steel shaft that rotates in a permanently lubricated ball bearing.

The pump inlet connects to the bottom of the radiator by a rubber hose. Coolant passes from the pump through the coolant passages in the block and cylinder head. This is done in order to absorb and carry away excess engine heat.

Thermostat Description

A pellet-type thermostat in the coolant outlet passage controls the flow of the engine coolant. This allows proper engine warm-up and regulates coolant temperature. A wax pellet element in the thermostat expands when heated and contracts when cooled. The pellet connects through a piston to a valve. When the pellet heats, the valve opens. As the pellet cools, the contraction allows a spring to close the valve. The valve remains closed while the coolant is cold. This prevents circulation of coolant through the radiator.

When the engine warms and the thermostat valve opens, coolant flows through the radiator. In the radiator, heat is exchanged through the radiator into the surrounding air. This opening and closing of the thermostat permits enough coolant to enter the radiator in

Special Tools and Equipment

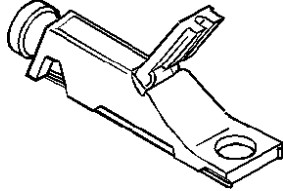
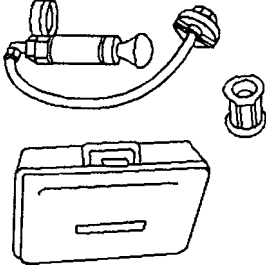
Illustration	Tool Number/Description
 <p style="text-align: right;">1409</p>	<p style="text-align: center;">J 223688 Coolant Tester Fahrenheit Scale</p>
 <p style="text-align: right;">1405</p>	<p style="text-align: center;">J 24460-01 Radiator Pressure Tester</p>

Section 3

Engine Electrical

Fastener Notice	3-2	Spark Plug Wires Not Operating Properly	3-28
Engine Electrical - 1.6L	3-3	Spark Plug Wire Resistance Test	3-28
Specifications	3-3	Spark Plug Wire Routing	3-28
Fastener Tightening Specifications	3-3	Repair Instructions	3-28
Battery Usage	3-3	Battery Cable Replacement	3-29
Starter Motor Usage	3-3	Battery Charging	3-30
Generator Usage	3-3	Charging Procedure	3-30
Spark Plug Usage	3-3	Charging Time Required	3-31
Schematic and Routing Diagrams	3-3	Battery Charge Low or Completely Discharged	3-32
Wiring Schematic - Genie 1.6L GM Dual Fuel	3-4	Battery Replacement	3-32
Wiring Diagram - 1.6L Generic	3-5	Jump Starting in Case of Emergency	3-33
Wiring Schematic - Tennant 1.6L GM GAS/L.P.G.	3-6	Jump Starting Procedure	3-33
Component Locator	3-7	Starter Motor Inspection	3-34
Engine Electrical Components	3-7	Cleaning Procedure	3-34
Engine Electrical Component Locator Views	3-7	Component Electrical Testing	3-34
Diagnostic Information and Procedures	3-8	Armature Bearing Replacement	3-34
Charging System Check	3-8	Starter Motor Replacement	3-35
Starting System Check	3-8	Generator Replacement	3-36
Battery Common Causes of Failure	3-9	DIS Ignition Module Replacement	3-37
Battery Cautions	3-9	Setting Ignition Timing	3-37
Important Battery Diagnosis Information	3-9	Crankshaft Position (CKP) Sensor Replacement	3-37
Battery Check	3-10	Description and Operation	3-39
Battery Terminal Check	3-11	Starting System Description	3-39
Battery Not Operating Properly	3-12	Cranking Circuit	3-39
Battery Electrical Drain/Parasitic Load	3-13	Starter Motor	3-39
Current Drain Test	3-16	Starting System Circuit Description	3-39
Battery Hydrometer Displays Dark or Yellow Dot	3-18	Batteries	3-40
Battery is Undercharged or Overcharged	3-18	Built-In Hydrometer - If Equipped	3-40
Engine Cranks/Cranks Slowly but Does Not Start ...	3-19	Charging System Description	3-41
Generator Noise Test	3-20	SI Series Generators	3-41
Generator Not Operating Properly	3-20	Voltage Regulator	3-42
Generator Assembly Bench Check	3-23	Charging System Circuit Description	3-42
Starter Motor Noise Diagnosis	3-23	Ignition System Description	3-43
High-Pitched Whine During Cranking	3-23	Ignition Switch	3-43
High-Pitched Whine after the Engine Fires	3-23	DIS Ignition Module	3-43
Loud Whoop Sound after the Engine Fires	3-24	Spark Plugs	3-44
Rumble Growl or Knock	3-24	Secondary Wiring	3-44
Starter No Load Test	3-24	Crankshaft Position (CKP) Sensor	3-44
Starter Solenoid Does Not Click	3-25	Special Tools and Equipment	3-45
Starter Solenoid Clicks, Engine Does Not Crank or Cranks Slowly	3-26		

Fastener Notice

NOTICE: Always use the correct fastener in the proper location. When you replace a fastener, use **ONLY** the exact part number of that application.

UNLESS OTHERWISE SPECIFIED, Do Not use supplemental coatings (paints, greases or other corrosion inhibitors) on threaded fasteners or fastener joint interfaces. Generally, such coating adversely affect the fastener torque and the joint clamping force, and may damage the fastener.

When you install fasteners, use the correct tightening sequence and specifications.

Following these instructions can help you avoid damage to parts and systems.

Engine Electrical - 1.6L

Specifications

Fastener Tightening Specifications

Application	Specification	
	Metric	English
Battery Case Retainer Nut or Bolt	18 N•m	13 lb ft
Battery Case Top Bar Nut	10 N•m	89 lb in
Battery Side Terminal Bolts	12 N•m	106 lb in
Battery Top Terminal Nuts	18 N•m	13 lb ft
DIS Ignition Module Mounting Bolts	8 N•m	71 lb in
Generator Output (Battery) Terminal Nut	8 N•m	71 lb in
Bottom Generator to Mounting Bracket Bolt	35 N•m	26 lb ft
Top Generator to Bracket Mounting Bolt	20 N•m	15 lb ft
Spark Plugs	25 N•m	18 lb ft
Solenoid (Starter Motor) Positive (+) Battery Cable Terminal Nut	15 N•m	11 lb ft
Starter Motor Mounting Bolt/Stud	25 N•m	18 lb ft
Starter Motor S terminal Nut	6.5 N•m	55 lb in

Battery Usage

Cold Cranking Amperes Rating	Reserve Capacity	Load Test Amperes
600	100	340

Starter Motor Usage

Engine Application	Part Number	Series
1.6L	93288991	Bosch

Generator Usage

Engine Application	Generator Series	Rated Output (Amperes)	Rotor Field Resistance (Ohms at 80°F)	Rotation Viewing Drive End	Load Test (Amps)
1.6L	7SI	70	2.1-2.4	CW	91

Spark Plug Usage

Engine Application	Spark Plug Type	Spark Plug Gap	
		Metric	English
1.6L	AC Delco 93206675	0.8 - 0.9 mm	0.031 - 0.035 in

SCHEMATIC AND ROUTING DIAGRAMS

Note: The schematic and wiring diagrams shown on the next few pages are only current up to the printing date of this book. Please contact Power Solutions, Inc. for additional schematics at 800-551-2938.

Schematic and Routing Diagrams - Continued

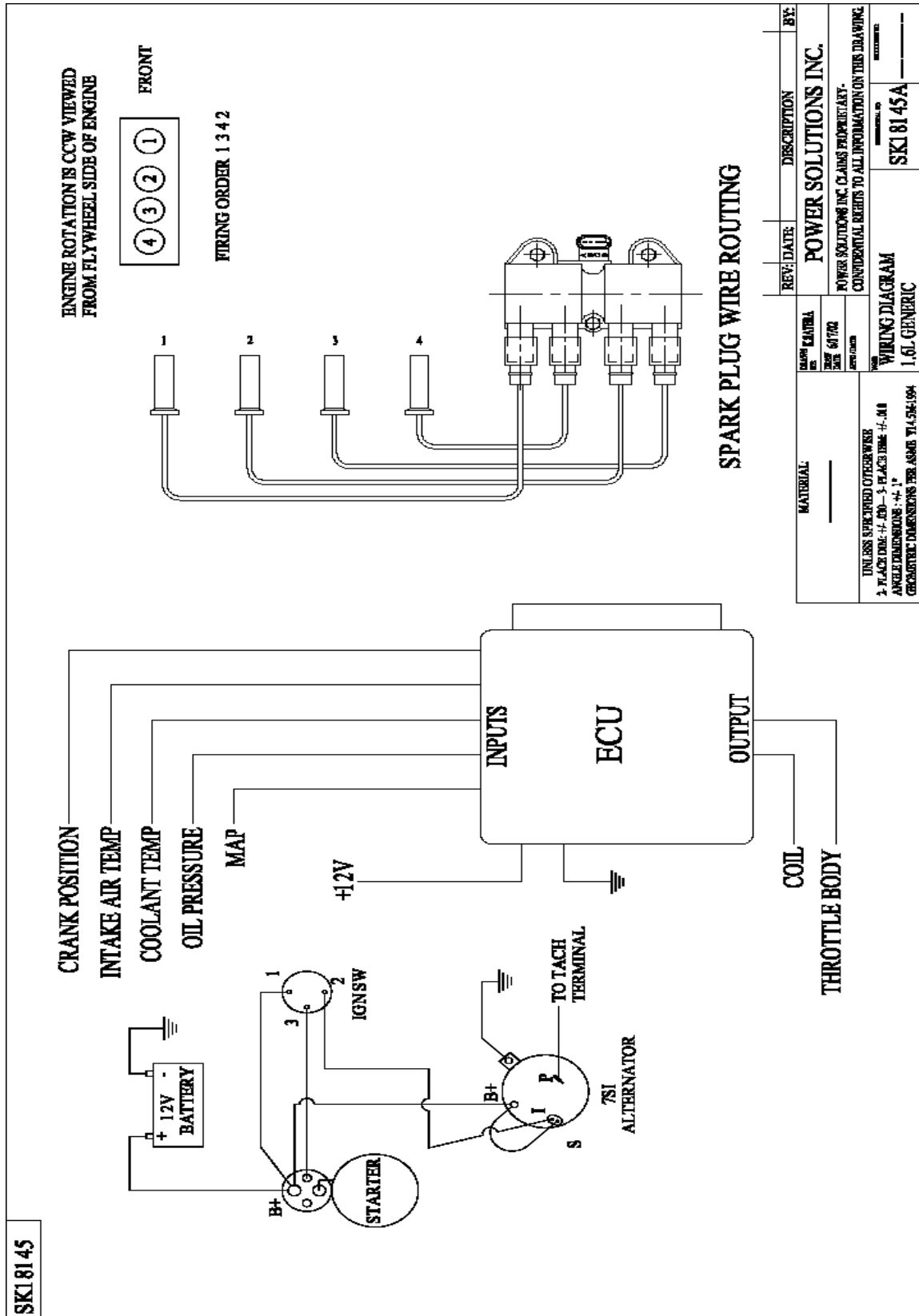

Component Locator

Engine Electrical Components

Name	Location	Locator View	Wiring Diagram
Battery	Determined by customer usage and application	—	N/A
Generator	At the RH front of the engine	<i>Engine Electrical Component Locator Views</i>	<i>Page 3-4</i>
Ignition Switch	Determined by customer usage and application	—	N/A
Starter Motor	At the lower RH side of the engine	<i>Engine Electrical Component Locator Views</i>	N/A
Starter Solenoid	On the starter at the lower RH side of the engine	<i>Engine Electrical Component Locator Views</i>	<i>Page 3-4</i>

Engine Electrical Component Locator Views

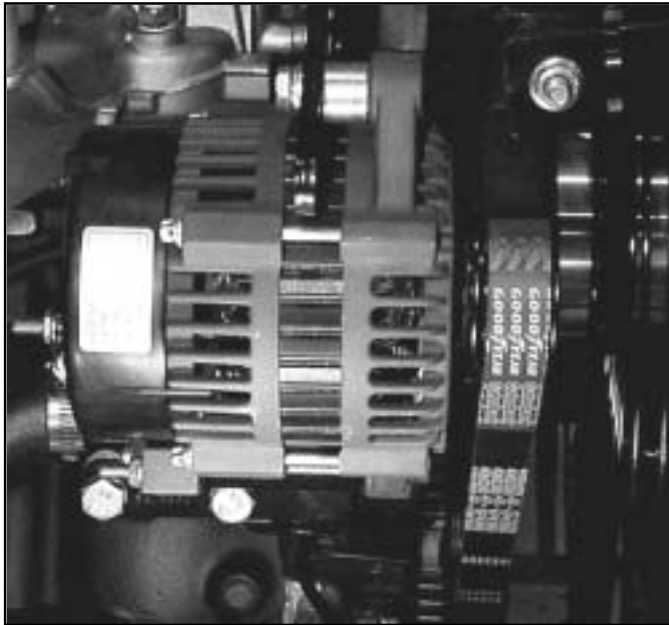

80363002

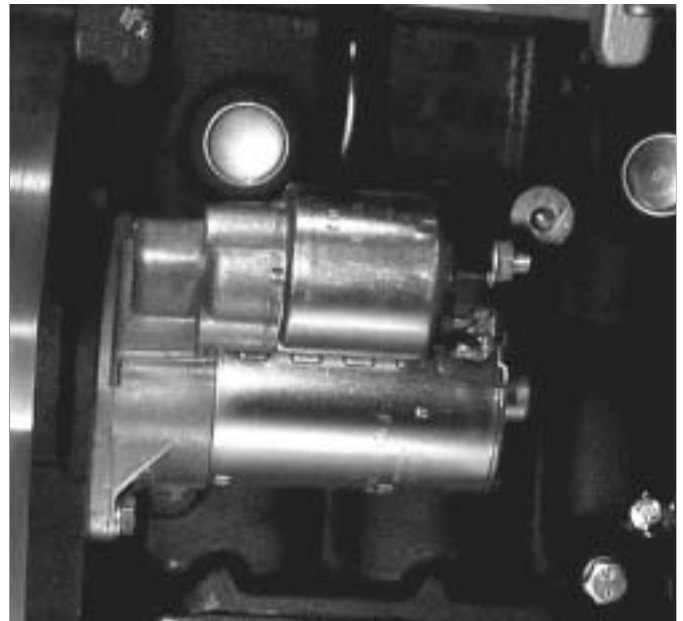

80363003

Diagnostic Information and Procedures

Charging System Check

Step	Action	Normal Result(s)	Abnormal Result* / Action
1	Check the generator pulley drive belt tension.	The drive belt is correctly tensioned.	Adjust or replace the drive belt Refer to <i>Drive Belt Replacement</i> in Engine Cooling.
2	Visually inspect the battery for physical damage.	The battery case is not cracked or broken.	<i>Battery damaged. Replace Battery</i>
3	Inspect the battery terminal connections.	The battery terminals are clean and tight.	Refer to <i>Fastener Tightening Specifications</i> ; Clean or Replace Battery Cable
4	Visually inspect the built-in battery hydrometer (if equipped).	The battery hydrometer displays a green dot (if equipped).	<i>Battery Hydrometer Displays Dark or Yellow Dot (if equipped)</i>
5	Inspect the generator output terminal for a loose connection.	The generator output terminal is clean and tight.	Refer to <i>Fastener Tightening Specifications</i>
6	Inspect the generator connector for looseness or damaged terminals.	Generator connector terminals are not loose or damaged.	<i>Connector Repairs</i>
7	Battery Not Operating Properly	The battery passes the load test.	<i>Replace Battery</i>
8	Generator Not Operating Properly	The generator passes the electrical test.	Refer to <i>Generator Replacement</i>
9	1. Connect a digital multimeter across the battery terminals. 2. Start the engine and allow it to idle.	The voltmeter is in the normal range.	<i>*Voltmeter Displaying High or Low</i>
10	Increase the engine speed to 2500 RPM.	The voltmeter is in the normal range.	<i>*Voltmeter Displaying High or Low</i>

*Refer to the appropriate symptom diagnostic table for the applicable abnormal result.

Starting System Check

Step	Action	Normal Result(s)	Abnormal Result(s)*
1	1. Disengage any power transmission component, if applicable. 2. Turn the ignition switch to RUN, leaving the engine off.	The voltmeter shows approximately 12 V.	<i>Charging System Check</i>
2	Turn the ignition switch to START.	The engine cranks normally and the starter does not make unusual noises.	<i>Starter Solenoid Does Not Click Starter Solenoid Clicks, Engine Does Not Crank Starter Motor Noise Diagnosis</i>

*Refer to the appropriate symptom diagnostic table for the applicable abnormal result.

Battery Common Causes of Failure

- The battery may be damaged.
 - Cracked case
 - Corroded battery cable terminals
 - Loose battery cable connections
 - Loose battery hold-down
 - There may be a mechanical problem.
 - Loose or slipping drive belt
 - Structural failure of aftermarket mounting brackets
 - Misaligned pulleys
- There may be an electrical drain caused by a parasitic load.
- The electrical load may be greater than the output of the generator.
- There may be an electrical problem in the charging system.
 - Poor ground circuits
 - Electrical shorts
 - Faulty generator

Battery Cautions

Caution: Batteries produce explosive gases. Batteries contain corrosive acid. Batteries supply levels of electrical current high enough to cause burns. Therefore, in order to reduce the risk of personal injury while working near a battery, observe the following guidelines:

- **Always shield your eyes.**
- **Avoid leaning over the battery whenever possible.**
- **Do not expose the battery to open flames or sparks.**
- **Do not allow battery acid to contact the eyes or the skin.**
 - **Flush any contacted areas with water immediately and thoroughly.**
 - **Get medical help.**

Important Battery Diagnosis Information

PSI does not supply batteries to equipment manufacturers. However, on the following pages, you will find some generic methods used to diagnosis common battery problems. You may need to contact the equipment manufacturer for specific procedures for the battery you are working with.

Battery Check

Step	Action	Normal Result(s)	Abnormal Result(s)*
1	1. Inspect the following areas for battery acid: <ul style="list-style-type: none"> • The battery case • The battery tray • The area around and underneath the battery tray 2. Inspect the battery for a cracked, broken, or damaged case.	<ul style="list-style-type: none"> • The battery case, the battery tray, and the surrounding area are dry. • The battery is not cracked, broken, or damaged. 	Replace battery.
2	Compare the Cold Cranking Amperage (CCA) and the Reserve Capacity (RC) of the battery or the Equipment Manufacturer's specification	The ratings of the vehicle battery meet or exceed the CCA and the RC of the original equipment specification.	Replace battery.
3	Inspect the battery hydrometer for a green dot (if equipped).	The battery hydrometer displays a green dot.	<ul style="list-style-type: none"> • If the battery hydrometer has a dark dot (no green dot visible), test the condition of the battery. Refer to <i>Battery Not Operating Properly</i>. • If the battery hydrometer has a yellow dot, check the battery for low electrolyte. Refer to <i>Battery Hydrometer Displays Dark or Yellow Dot</i>.
4	Turn the ignition key to START and check to see if the engine cranks normally and starts.	The engine cranks normally and starts.	<ul style="list-style-type: none"> • Engine does not crank or cranks slowly, refer to <i>Battery Not Operating Properly</i>. • Engine cranks normally but does not start, refer to <i>Engine Cranks But Does Not Run</i> in Engine Controls. • Engine starts but does not start overnight or after a couple of days, refer to <i>Charging System Check</i> and <i>Battery Electrical Drain/Parasitic Load</i>.
5	1. Inspect the battery for proper installation and retention in the battery tray. 2. Inspect the battery terminals for clean and tight connections.	<ul style="list-style-type: none"> • The battery is firmly held in place in the tray and the hold-down bolt is properly tightened. • The battery terminals are clean and tight. 	<ul style="list-style-type: none"> • Install the battery in the battery tray correctly. • Refer to <i>Battery Terminal Check</i>.

*Refer to the appropriate symptom diagnostic table for the applicable abnormal result.

Battery Terminal Check

Step	Action	Value(s)	Yes	No
<p>Caution: Refer to Battery Cautions on page 3-7.</p>				
1	<p>1. Turn the ignition key to the OFF position. 2. Attempt to rotate the negative (-) battery cable connector clockwise with light finger pressure. Does the negative (-) connector rotate?</p>	—	Go to Step 2	Go to Step 3
2	<p>Use a torque wrench in order to verify the torque to loosen the negative (-) battery terminal bolt. Is the torque above the specified value?</p>	10 N•m (84 lb in)	Go to Step 4	Go to Step 3
3	<p>Disconnect the negative (-) battery cable. Is the cable disconnected?</p>	—	Go to Step 5	—
4	<p>Ensure the negative (-) battery cable is disconnected. Inspect for the following conditions and repair as needed:</p> <ul style="list-style-type: none"> • The cable bolt is too long or misformed at the end. • There is foreign material present inside the nut in the battery terminal. • Damage to the battery terminal face or cable connector ring. <p>Is the repair complete?</p>	—	Go to Step 5	—
5	<p>Rotate the positive (+) battery cable connector clockwise with light finger pressure. Does the positive (+) connector rotate?</p>	—	Go to Step 6	Go to Step 7
6	<p>Use a torque wrench in order to verify the torque to loosen the positive (+) battery terminal bolt. Is the torque above the specified value?</p>	10 N•m (84 lb in)	Go to Step 8	Go to Step 7
7	<p>Disconnect the positive (+) battery cable. Is the cable disconnected?</p>	—	Go to Step 9	—
8	<p>1. Ensure the positive (+) battery cable is disconnected. 2. Inspect for the following conditions and repair as needed:</p> <ul style="list-style-type: none"> • The cable bolt is too long or misformed at the end. • There is foreign material present inside the nut in the battery terminal. • Damage to the battery terminal face or cable connector ring. <p>Is the repair complete?</p>	—	Go to Step 9	—
9	<p>1. Clean and wire brush the lead face of both battery terminals and the metal contact rings in both cable connectors. 2. Remove the bolts from the cable connectors in order to provide access to the connector rings as needed. 3. If either the battery terminals or the cable rings are excessively damaged or corroded, replace as needed. Are the metal connecting parts clean and in good condition?</p>	—	Go to Step 10	—

Battery Terminal Check (cont'd)

Step	Action	Value(s)	Yes	No
10	1. Connect the positive (+) battery cable to the battery positive (+) terminal. 2. Tighten the cable bolt to the specified value. Is the cable bolt properly tightened?	12 N•m (106 lb in)	Go to <i>Step 11</i>	—
11	1. Connect the negative (-) battery cable to the battery negative (-) terminal. 2. Tighten the cable bolt to the specified value. Is the cable bolt properly tightened?	12 N•m (106 lb in)	Battery Terminals OK	—

Battery Not Operating Properly

Notice: Always turn the ignition switch OFF when connecting or disconnecting batteries, battery chargers, or jumper cables. Failure to do so may damage the electronic control unit or other electrical components.

Important: The battery test using the *J 42000* Battery Tester requires correct connections to the battery terminals. A failure to obtain the correct connections during the test may result in replacing the battery unnecessarily. Adhere to the following instructions in order to avoid an incorrect diagnosis due to poor connections:

- When testing the equipment with the battery cables still connected, rock the *J 42000* clips back and forth on the terminal bolt in order to cut through any coating or oxidation that may be present on the bolt.
- Even new bolts contain a protective coating that may insulate or cause a resistance in the test circuit.
- If it is uncertain that correct connections can be made to the battery terminal bolts in the equipment, perform the following steps:
 1. Disconnect the battery cables.
 2. Install the test adapters on the terminals.
 3. Follow the instructions for testing the battery outside of the equipment.
- If a REPLACE BATTERY result is obtained for a battery tested in the equipment with the battery cables connected, perform the following steps:
 1. Disconnect the battery cables.
 2. Install the approved battery terminal adapters.
 3. Follow the instructions for testing the battery outside of the equipment.
 4. Replace the battery only if the second test shows a REPLACE BATTERY result.
- For warranty purposes, use the test code from the second test.
- On side post batteries, use the approved terminal adapters. Do not use any common bolts or a combination of bolts, nut, and washers as adapters when testing the battery.
- Use the test adapters that are provided with the *J 42000* tester or GM part number 12303040 terminal adapters. If the adapters that are provided with the *J 42000* tester require replacement, only use adapters with the GM part number 12303040. Any other adapters may not contact the correct areas of the battery terminal, causing resistance that may result in an invalid battery test result.
- In order to test the top terminal, threaded stud batteries outside of the equipment, use GM part number 12303040 adapters. Do not connect the tester to the plain threaded terminals.

Important: For warranty purposes, always place the test code displayed by the tester on the repair order. The number is a unique identifier that describes the test data for a particular battery at a particular time.

While the test code may occasionally repeat when retesting the same battery, it is more likely that a different code will result each time the battery is tested.

Battery Not Operating Properly

Step	Action	Value(s)	Yes	No
Tools Required J 42000 Battery Tester J 39200 Digital Multimeter (DMM) P/N 12303040 Battery Terminal Adapters (Side Post Batteries Only)				
1	Has the Battery Check been performed?	—	Go to Step 2	Go to Battery Check.
2	Is the battery in the vehicle, with the battery cables connected?	—	Go to Step 4	Go to Step 3
3	1. Lightly wire brush the lead faces of both battery terminals. 2. Install the terminal adapters to both of the battery terminals. Refer to P/N 12303040. Are the battery terminal adapters installed?	—	Go to Step 6	—
4	Ensure that the battery terminals are clean, tight, and in good condition Are the terminal connections OK?	—	Go to Step 5	Go to Battery Terminal Check.
5	1. Turn the ignition switch to the OFF position. 2. Turn the electrical loads and all accessory lights to the OFF position. Are all of the electrical loads and accessory lights OFF?	—	Go to Step 6	—
6	Important: When testing the battery on the equipment, connect the tester directly to the cable bolts. Do not connect either of the tester clamps to a remote terminal, such as a junction block or a jump start terminal. The use of a remote terminal will cause invalid test results. 1. Connect the red clamp on the J 42000 to the adapter or the cable bolt on the battery positive (+) terminal. 2. Connect the black clamp on the tester to the adapter or cable bolt on the battery negative (-) terminal. 3. Rock both of the tester clamps back and forth in order to cut through to the bare metal. The message GM MICRO 410 should appear for a short time on the tester display, and then change to SELECT TEST. Does the display read SELECT TEST?	—	Go to Step 10	Go to Step 7
7	Does a CHECK CONNECTION message appear on the J 42000 tester display?	—	Go to Step 8	Go to Step 9
8	Inspect the tester connections to the battery terminal adapters or cable bolts for the following conditions: <ul style="list-style-type: none"> • Both sides of each tester clamp must make the correct contact. • Ensure that the red clamp is connected to the positive (+) terminal and the black clamp is connected to the negative (-) terminal. • If the adapters or the bolts appear corroded, rock the clamps back and forth in order to ensure a correct connection. • Use a wire brush in order to clean the adapters or cable bolts, if needed. Does the tester display now read SELECT TEST?	—	Go to Step 17	Go to Step 12

Battery Not Operating Properly (cont'd)

Step	Action	Value(s)	Yes	No
9	Use a <i>J 39200</i> digital multimeter (DMM) in order to test the battery voltage with the <i>J 42000</i> tester connected. Is the voltage at or below the specified value?	5.5 V	Go to Step 25	Go to Step 29
10	Use the scroll keys on the <i>J 42000</i> tester to select either IN-VEHICLE (for on-equipment testing) or OUT-OF-VEHICLE (for off-equipment testing), depending on the following conditions: <ul style="list-style-type: none"> Use IN-VEHICLE testing if the battery cables are connected to the battery. Use OUT-OF-VEHICLE testing if the battery cables are disconnected and the terminal adapters are installed. Was IN-VEHICLE testing selected?	—	Go to Step 11	Go to Step 12
11	The display on the tester will show ALWAYS TEST AT BATTERY TERMINAL, and then change to SELECT RATING. Does the display read SELECT RATING?	—	Go to Step 13	Go to Step 37
12	For off equipment testing, the display on the tester will show USE TERMINAL ADAPTERS, and then change to SELECT RATING. Does the tester display read SELECT RATING?	—	Go to Step 13	Go to Step 37
13	Important: Refer to the Battery Usage Chart or Equipment manufacturer's specifications for the correct rating for the original equipment (OE) battery. If a battery with a lower cold cranking amperage (CCA) rating has been installed on the equipment, the battery may not perform properly during the use of the vehicle even if the battery passes the test using the <i>J 42000</i> tester. <ol style="list-style-type: none"> Use the scroll keys on the <i>J 42000</i> tester to select the CCA rating on the battery label. Press the ENTER key on the tester. TESTING will appear briefly on the display, followed by the results of the test. Are the results of the test displayed?	—	Go to Step 14	—
14	Does GOOD BATTERY appear on the <i>J 42000</i> display?	—	Go to Step 22	Go to Step 15
15	Does GOOD-RECHARGE appear on the tester display?	—	Go to Step 25	Go to Step 16
16	Does CHARGE amp RETEST appear on the tester display?	—	Go to Step 29	Go to Step 17
17	Does REPLACE BATTERY appear on the tester display?	—	Go to Step 26	Go to Step 18
18	Does BAD CELL-REPLACE appear on the tester display?	—	Go to Step 28	Go to Step 19
19	Does SURFACE CHARGE DETECTED appear on the tester display?	—	Go to Step 30	Go to Step 20
20	Does SELECT TEMP appear on the tester display?	—	Go to Step 33	Go to Step 21
21	Does SYSTEM NOISE-CHECK LOADS, alternating with RETESTING, appear on the tester display?	—	Go to Step 34	Go to Step 37

Battery Not Operating Properly (cont'd)

Step	Action	Value(s)	Yes	No
22	1. Press the CODE button on the <i>J 42000</i> . 2. For warranty purposes, write the displayed code on the repair order. Is the green dot (if applicable) visible in the battery's hydrometer?	—	Go to <i>Step 24</i>	Go to <i>Step 23</i>
23	Charge the battery. Refer to <i>Battery Charging</i> . Is the green dot (if applicable) visible in the hydrometer?	—	Go to <i>Step 24</i>	Go to <i>Step 39</i>
24	The battery is OK. Install the battery. Refer to <i>Battery Replacement</i> . Is the action complete?	—	System OK	—
25	1. Press the CODE button on the <i>J 42000</i> tester. 2. For warranty purposes, write the displayed code on the repair order. 3. Charge the battery. Refer to <i>Battery Charging</i> . Is the green dot (if applicable) visible in the hydrometer?	—	Go to <i>Step 24</i>	—
26	Was the battery tested in the vehicle with the battery cables still attached?	—	Go to <i>Step 27</i>	Go to <i>Step 28</i>
27	Notice: Always turn the ignition switch OFF when connecting or disconnecting batteries, battery chargers, or jumper cables. Failure to do so may damage the electronic control unit or other electrical components. 1. Turn the ignition switch to the OFF position. 2. Disconnect the negative (-) battery cable. 3. Disconnect the positive (+) battery cable. Are the actions complete?	—	Go to <i>Step 3</i>	—
28	1. Press the CODE button on the <i>J 42000</i> . 2. For warranty purposes, write the displayed code on the repair order. 3. Replace the battery. Refer to <i>Battery Replacement</i> . Is the action complete?	—	Go to <i>Step 2</i>	—
29	1. Press the CODE button on the <i>J 42000</i> . 2. For warranty purposes, write the displayed code on the repair order. 3. Charge the battery. Refer to <i>Battery Charging</i> . Is the green dot (if applicable) visible in the battery hydrometer?	—	Go to <i>Step 2</i>	—
30	Important: Surface charge removal is only necessary when the tester detects that a surface charge may affect the results of the test. The tester will not complete the testing sequence until the surface charge is removed. Follow the tester prompts in order to remove the surface charge by turning the vehicle's headlights ON and OFF. If the sequence is followed properly, the tester will automatically complete the test. If the sequence is not followed properly, the tester will display the message DISCONNECT AND RETEST. Does the DISCONNECT AND RETEST message appear?	—	Go to <i>Step 31</i>	Go to <i>Step 32</i>
31	Disconnect the <i>J 42000</i> from the battery terminals. Is the action complete?	—	Go to <i>Step 2</i>	—
32	The tester will display the word RETESTING and show the CCA rating that was selected for the test. If the test is successfully completed, the test results will be displayed. Do the test results appear on the display?	—	Go to <i>Step 14</i>	Go to <i>Step 36</i>

Generator Not Operating Properly (cont'd)

Step	Action	Value(s)	Yes	No
7	<ol style="list-style-type: none"> 1. Disconnect the negative battery cable from the battery. 2. Disconnect the battery (white) wire from the generator battery terminal. 3. Connect the red ammeter lead to the generator battery terminal and the black lead to the generator battery wire terminal. 4. Re-connect the negative battery cable to the battery. 5. Observing polarity, connect the voltmeter leads to the positive and negative battery terminals. Is the voltage above the specified value?	12 V	Go to Step 9	Go to Step 8
8	<ol style="list-style-type: none"> 1. Recheck the connections that were made in Step 7. 2. Correct the connections if they were reversed. 	—	Go to Step 9	—
9	<p>Caution: Make sure that the load is completely turned off before connecting or disconnecting the carbon pile load tester to the battery. Otherwise, sparking could ignite battery gasses which are extremely flammable and may explode violently.</p> <ol style="list-style-type: none"> 1. Prior to connecting a carbon pile load tester, ensure that the load dial of the carbon pile tester is turned completely to the OFF position. Connect the cable leads of the carbon pile tester to the battery terminals. 2. Start the engine and allow it to idle briefly. 3. Increase the engine speed to 2500 RPM. 4. While maintaining the engine speed at 2500 RPM increase the load until the generator output is within 10 amps of the rated output (load test) value given in Generator Usage. As the load is increased, is the generator capable of producing the rated output value load test current specified in Generator Usage within 10 amps?	70 A	Go to Step 10	Replace or repair the generator
10	Maintain the engine speed at 2500 RPM and continue to operate the generator at the load test value. Is the voltage within the specified value?	13.5 V to 15.1 V	Generator OK	Go to Step 11
11	<ol style="list-style-type: none"> 1. Maintain the engine speed at 2500 RPM and continue to operate the generator at the load test value. 2. Connect a digital multimeter between the generator battery wire terminal to the battery positive (+) terminal. Is the voltage above the specified value?	0.5 V	Go to Step 13	Go to Step 12
12	<ol style="list-style-type: none"> 1. Maintain the engine speed at 2500 RPM and continue to operate the generator at the load test value. 2. Connect a digital multimeter from the generator metal housing to the battery negative (-) terminal. Is the voltage above the specified value?	0.5 V	Go to Step 14	Go to Step 15

Generator Not Operating Properly (cont'd)

Step	Action	Value(s)	Yes	No
13	<p>Caution: Make sure that the load is completely turned off before connecting or disconnecting a carbon pile load tester to the battery. Otherwise, sparking could ignite battery gasses which are extremely flammable and may explode violently.</p> <ol style="list-style-type: none"> 1. Disconnect the digital multimeter. 2. Turn OFF the load in the carbon pile tester. 3. Turn the ignition switch to OFF to stop the engine. 4. Disconnect the carbon pile tester cables from the battery. 5. Disconnect the battery negative terminal. 6. Inspect the circuit between the battery positive (+) terminal and the generator output terminal for a high-resistance connection. Disassemble and clean all connections in this circuit. 7. Assemble the connections and tighten to specifications. 8. Connect the battery negative (-) terminal. Tighten to specifications. Refer to Fastener Tightening Specifications. <p>Is the repair complete?</p>	—	Go to Charging System Check	—
14	<p>Caution: Make sure that the load is completely turned off before connecting or disconnecting a carbon pile load tester to the battery. Otherwise, sparking could ignite battery gasses which are extremely flammable and may explode violently.</p> <ol style="list-style-type: none"> 1. Disconnect the digital multimeter. 2. Turn OFF the load in the carbon pile tester. 3. Turn the ignition switch to OFF to stop the engine. 4. Disconnect the carbon pile tester cables from the battery. 5. Inspect the ground circuit for high resistance from the battery negative (-) terminal to the generator housing. Disassemble and clean all connections. 6. Assemble the connections and tighten to specifications. Refer to <i>Fastener Tightening Specifications</i>. <p>Is the repair complete?</p>	—	Go to Charging System Check	—
15	<p>Replace the voltage regulator.</p> <p>Is the repair complete?</p>	—	Go to Charging System Check	—

Generator Assembly Bench Check

This test requires both a fully charged battery and a generator test stand to operate the generator. The generator can be tested quicker and easier while it is still on the equipment. Refer to *Generator Not Operating Properly*.

1. Ensure the carbon pile is off before making connections as shown.
 - The ground polarity of the generator and battery must be the same.
 - The battery must be fully charged.
 - Use a 30-500 ohm resistor between the battery and the BAT terminal of the generator.
2. Slowly increase the generator speed and observe the voltage.
3. If the voltage is uncontrolled and increases above 16 volts, the rotor field is shorted, the regulator is not working properly, or both. A shorted rotor field coil can cause repeat regulator failure.
4. If the voltage is below 16 volts, increase speed and turn on and adjust the carbon pile to obtain maximum amperage output. Maintain the voltage above 13 volts.
5. If the output is within 15 amperes of the rated output, the generator is good. If the output is not within 15 amperes of the rated output, replace the generator.

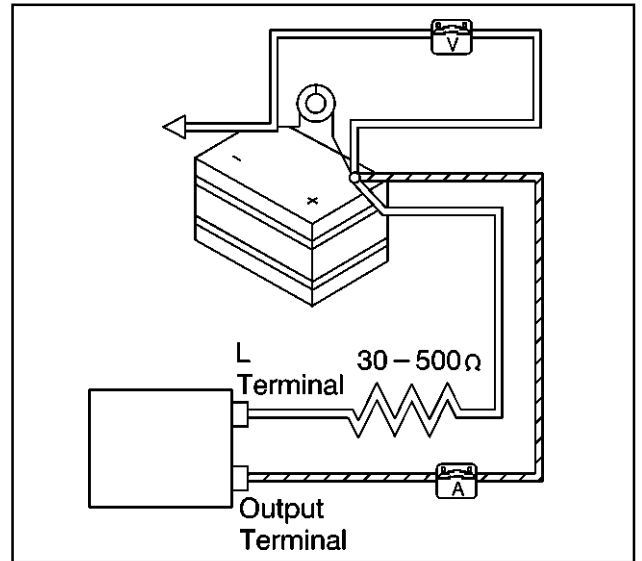

350774

STARTER MOTOR NOISE DIAGNOSIS

High-Pitched Whine During Cranking

Problem	Action
DEFINITION: A high-pitched whine during cranking (before the engine fires), but the engine cranks and fires normally.	
The distance is too great between the starter pinion and the flywheel.	Remove the shims at the starter mount. Refer to <i>Starter Pinion Clearance Check</i> .

High-Pitched Whine After the Engine Fires

Problem	Action
DEFINITION: A high-pitched whine, after the engine fires, as the key is being released. The engine cranks and fires normally. This complaint is often diagnosed as starter hang-in or solenoid weak.	
The distance is too small between the starter pinion and the flywheel (flywheel runout contributes to the intermittent nature of the problem).	Add shims at the starter mount. Refer to <i>Starter Pinion Clearance Check</i> .

Loud Whoop Sound after the Engine Fires

Problem	Action
DEFINITION: A loud whoop sound after the engine fires, but while the starter is still held engaged. The sound is similar to a siren if the engine is revved while the starter is engaged.	
The starter motor clutch is worn.	<ol style="list-style-type: none"> 1. Remove the starter motor. Refer to <i>Starter Motor Replacement</i>. 2. Check the clutch. Refer to <i>Starter Motor Inspection</i>.

Rumble, Growl, or a Knock

Problem	Action
DEFINITION: A rumble, growl, or a knock (in severe cases) as the starter is coasting down to a stop after starting the engine.	
The starter armature is bent or unbalanced.	<ol style="list-style-type: none"> 1. Remove the starter motor. Refer to <i>Starter Motor Replacement</i>. 2. Check the clutch. Refer to <i>Starter Motor Inspection</i>.

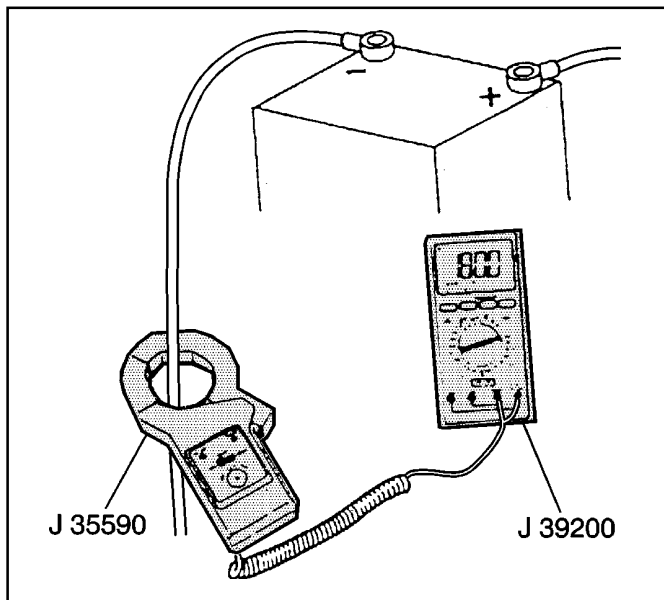

182233

Starter No Load Test

Tools Required

- J 35590 Current Clamp
- J 39200 Digital Multimeter, or Equivalent

Notice: Never operate the starter motor more than 15 seconds at a time without pausing in order to allow it to cool for at least 2 minutes. Overheating will damage the starter motor.

Important: Verify that the battery is in good condition. Refer to *Battery Check*.

1. Disable the fuel system. Refer to *Engine Controls*.
2. Calculate the current draw by doing the following:
 - 2.1. Select the 200 amp or the 2000 amp scale on the J 35590.
 - 2.2. Zero the current clamp.
 - 2.3. Clamp the current clamp to the battery negative cable.
 - 2.4. Crank the engine and observe the meter readings. The reading should be 65-95 amps.
- If the amperage is over 95 amps, an internal starter failure may be the cause.
- If the amperage is under 65 amps, a battery cable or connection may be the cause.

Starter Solenoid Does Not Click

Step	Action	Value(s)	Yes	No
1	Has the Battery Check been performed?	—	Go to Step 2	Go to Battery Check.
2	1. Probe the starter solenoid with a digital multimeter from terminal S to engine ground. 2. Turn the ignition switch to the START position. Does the voltage measure more than the specified value?	10 V	Go to Step 3	Go to Step 4
3	1. Ensure that the battery terminals are clean and tight. 2. Remove the starter. 3. Clean the starter motor mounting bolts, the starter motor and the mounting surface. 4. Install the starter. 5. Attempt to start the engine. 6. If the engine does not start, replace the starter motor. Refer to <i>Starter Motor Replacement</i> . Is the repair complete?	—	System OK	—
4	1. Probe the ignition switch with a digital multimeter from terminal S to engine ground. 2. Turn the ignition switch to the START position. Does the voltage measure more than the specified value?	10 V	Go to Step 5	Go to Step 6
5	Locate and repair the open circuit in the BLUE wire between the ignition switch S terminal and the starter solenoid S terminal. Is the repair complete?	—	System OK	—
6	Probe the starter solenoid with a digital multimeter from terminal B to engine ground. Is the voltage equal to or more than the specified value?	12 V	Go to Step 8	Go to Step 7
7	Locate and repair the open circuit in the positive battery cable between the battery and the starter solenoid B terminal. Is the repair complete?	—	System OK	—
8	Probe the ignition switch with a digital multimeter from terminal B to ground. Is the voltage equal to or more than the specified value?	12 V	Go to Step 10	Go to Step 9
9	Locate and repair the open circuit in the WHITE wire between the ignition switch B terminal and the starter solenoid B terminal. Is the repair complete?	—	System OK	—
10	Replace the ignition switch. Is the repair complete?	—	System OK	—

Starter Solenoid Clicks, Engine Does Not Crank or Cranks Slowly

Step	Action	Value(s)	Yes	No
1	Was the Starting System Check performed?		Go to <i>Step 2</i>	Go to <i>Starting System Check</i> .
2	<ol style="list-style-type: none"> 1. Disconnect the DIS ignition electrical connector. 2. Connect a digital multimeter from the battery positive (+) terminal to the battery negative (-) terminal. 3. Turn the ignition switch to the START position. 4. Crank the engine for 15 seconds. 5. Measure the voltage at the end of cranking. 6. Reconnect the DIS ignition electrical connector. <p>Notice: Never operate the starter motor for more than 15 seconds at a time. Allow it to cool at least two minutes before cranking again. Excessive cranking can cause overheating, which will cause serious damage to the starter motor.</p> Does the voltage measure less than 9.6 volts?	9.6 V	Go to <i>Step 3</i>	Go to <i>Step 4</i>
3	<ol style="list-style-type: none"> 1. Perform the battery load test(s). Refer to <i>Battery Not Operating Properly</i>. 2. If the battery passes the load test, replace the starter motor. Is the repair complete?	—	System OK	—
4	<ol style="list-style-type: none"> 1. Ensure that the battery terminals and the battery terminal bolts are tight and are not corroded. 2. Connect a digital multimeter from the negative (-) battery terminal to the engine block. 3. Turn the ignition switch to the START position. 4. Observe the voltage while cranking the engine. <p>Notice: Never operate the starter motor for more than 15 seconds at a time. Allow it to cool at least two minutes before cranking again. Excessive cranking can cause overheating, which will cause serious damage to the starter motor.</p> Does the voltage measure more than 0.5 volts?	0.5 V	Go to <i>Step 5</i>	Go to <i>Step 6</i>
5	<ol style="list-style-type: none"> 1. Inspect the battery cable for a high resistance connection at the engine block. 2. If the connection is OK, replace the negative (-) battery cable. Refer to <i>Battery Cable Replacement</i>. <p>Caution: Before servicing any electrical component, the ignition key must be in the OFF or LOCK position and all electrical loads must be OFF, unless instructed otherwise in these procedures. If a tool or equipment could easily come in contact with a live exposed electrical terminal, also disconnect the negative battery cable. Failure to follow these precautions may cause personal injury and/or damage to the vehicle or its components.</p> Is the repair complete?	—	System OK	—

Starter Solenoid Clicks, Engine Does Not Crank or Cranks Slowly (cont'd)

Step	Action	Value(s)	Yes	No
6	1. Disconnect the DIS ignition electrical connector. 2. Connect a digital multimeter from the positive (+) battery terminal to starter solenoid terminal B. 3. Turn the ignition switch to the START position. 4. Observe the voltage while cranking. 5. Reconnect the DIS ignition electrical connector. Notice: Never operate the starter motor for more than 15 seconds at a time. Allow it to cool at least two minutes before cranking again. Excessive cranking can cause overheating, which will cause serious damage to the starter motor. Does the voltage measure more than 0.5 volts?	0.5 V	Go to Step 7	Go to Step 8
7	Inspect the battery cable for a high resistance connection at the starter solenoid B terminal. If the connection is OK, replace the positive (+) battery cable. Refer to Battery Cable Replacement. Caution: Before servicing any electrical component, the ignition key must be in the OFF or LOCK position and all electrical loads must be OFF, unless instructed otherwise in these procedures. If a tool or equipment could easily come in contact with a live exposed electrical terminal, also disconnect the negative battery cable. Failure to follow these precautions may cause personal injury and/or damage to the vehicle or its components. Is the repair complete?	—	System OK	—
8	Replace the starter motor. Refer to Starter Motor Replacement. Is the repair complete?	—	System OK	—

Spark Plug Wires Not Operating Properly

1. Check the routing of the wires, Improper routing can cause cross-firing.
2. Check each wire for any signs of cracks or splits in the wire.
3. Inspect each boot for signs of tears, piercing, arc through, or carbon tracking. If the boot needs to be replaced, twist it a half turn in each direction to break the seal before pulling on the boot to disconnect the wire.

Spark Plug Wire Resistance Test

Tools Required

J 39200 Digital Multimeter or Equivalent

1. Disconnect both ends of the wire that you wish to check.
Important: Ensure that the wire terminals are clean before proceeding.
2. Connect an ohmmeter lead to each end of the spark plug wire.
3. Gently twist the wire while observing the ohmmeter reading.
4. If the ohmmeter reads above 30,000 ohms, no matter how long the wire is, or fluctuates from infinity to any value, replace the wire.

Spark Plug Wire Routing

Wire routing must be kept intact during service and followed exactly when wires have been disconnected or when replacement of the wires becomes necessary. Failure to route the wires can result in cross-firing of the spark plugs or shorting of the wires to ground. The correct routing of the spark plug wires is shown in the illustration.

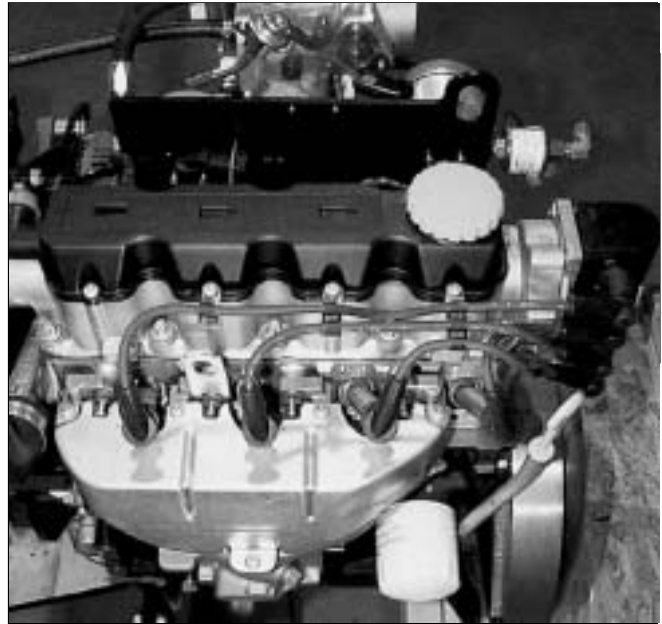

80363004

REPAIR INSTRUCTIONS

Battery Cable Replacement

Notice: Always turn the ignition switch OFF when connecting or disconnecting batteries, battery chargers, or jumper cables. Failure to do so may damage the electronic control unit or other electrical components.

Removal Procedure

Important: Whenever battery cables are replaced, always use a replacement cable that is the same type, diameter, and length. Always route the replacement cable in the same manner as the original cable. Always disconnect the negative (-) cable from the battery first.

Caution: Refer to *Battery Cautions on page 3-9*.

1. Remove the negative (-) battery cable from the battery.
2. Remove the positive (+) battery cable from the battery.
3. Remove the battery cable routing ties, if applicable.
4. Remove the starter solenoid nut and the positive (+) battery cable.
5. Remove the bolt and the negative (-) battery cable from the engine block.

Installation Procedure

Caution: Refer to *Battery Cautions on page 3-9*.

Notice: When installing the positive battery cable to the starter solenoid, the inner nut on the solenoid battery terminal must be tightened before the battery cable and the other leads are installed in the equipment. Failure to do so will result in damage to the solenoid terminal and/or the solenoid.

Notice: Refer to *Fastener Notice on page 3-2*.

1. Install the positive (+) battery cable to the starter solenoid with the nut.

Tighten

Tighten the battery positive (+) cable starter solenoid nut to 16 N•m (12 lb ft).

2. Install the negative (-) battery cable to the engine block or cylinder head with the bolt.

Tighten

Tighten the battery negative cable bolt to 40 N•m (30 lb ft).

3. Install the positive (+) battery cable to the battery.

Tighten

Tighten the battery side terminal bolts (if applicable) to 12 N•m (106 lb in).

Tighten the top terminal nuts (if applicable) to 18 N•m (13 lb ft).

4. Install the negative (-) battery cable to the battery.

Tighten

Tighten the battery side terminal bolts (if applicable) to 12 N•m (106 lb in).

Tighten the top terminal nuts (if applicable) to 18 N•m (13 lb ft).

5. Install the battery cable routing ties, if applicable.

Battery Charging

Basic Rules

When charging the battery, follow these basic rules:

- Use a charger with an end of charge voltage of 16.0 volts. The charger should have a voltmeter that is accurate within 1 percent.
- Ambient temperature should be 15-38°C (60-100°F). An extremely cold battery may not accept measurable current after several hours of charging.
- The charging area should be well ventilated.

On batteries with a built-in hydrometer:

- Do not charge the battery if the built-in hydrometer is clear or light yellow (3). If cranking problems exist, replace the battery.
- Do not charge a battery that seems to be frozen. Replace the frozen battery.
- A battery with a green dot showing in the hydrometer (1) does not require charging unless the battery has been discharged, such as from cranking.

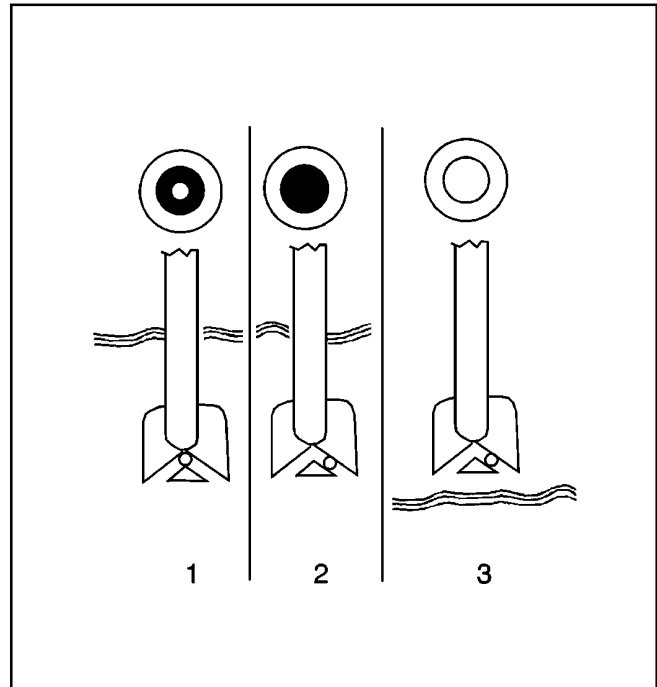

181056

Charging Procedure

Caution: Refer to Battery Cautions on page 3-9.

Notice: Always turn the ignition OFF when connecting or disconnecting battery cables, battery chargers, or jumper cables. Failing to do so may damage the Electronic Control Module (ECU) or other electronic components.

Important: Tighten the adapters against the lead terminals of the battery in order to keep the resistance between the adapters and the battery terminals to a minimum.

1. Make sure all connections to the charger are clean and tight. When charging side terminal batteries out of the equipment, install a pair of GM P/N 12303040 adapters.

Important: Do not use the charger settings for jump-starting equipment in order to charge the battery.

2. Set the charger for 12-volt batteries that gives the highest charge rate.

NOTE: On batteries with a built in hydrometer, charge the battery until the green dot (1) appears.

- Check the battery periodically while charging.
- Lightly tap the hydrometer on top in order to dislodge any air bubbles that may prevent a correct indication.

3. Discontinue charging, or reduce the charging rate, if the following apply:

- The battery feels hot, above 52°C (125°F)
- Violent gassing or spewing of electrolyte through the vent holes

After charging, test the battery. Refer to *Battery Not Operating Properly* and *Battery Electrical Drain/Parasitic Load*.

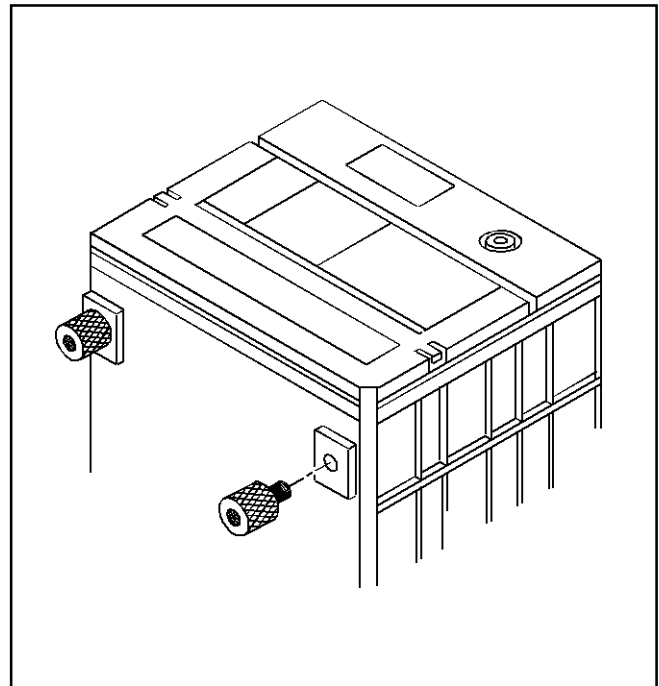

42433

Battery Not Operating Properly (cont'd)

Step	Action	Value(s)	Yes	No
33	<p>Important: Temperature compensation is only necessary when the tester detects that the battery temperature may affect the results of the test.</p> <ol style="list-style-type: none"> Use the scroll keys to indicate whether the internal temperature of the battery is above or below 0_C (32_F). Use the temperature of the battery to which the battery has been exposed for the past several hours in order to estimate the temperature. Push the ENTER key. <p>The tester will briefly display the RETESTING message and the CCA rating selected for the test. The test results will then show on the display.</p> <p>Do the test results show on the display?</p>	—	Go to Step 14	Go to Step 37
34	<ol style="list-style-type: none"> The tester detects that an electrical load is present (such as a light is on or the ignition key is not in the OFF position). Turn OFF all of the system electrical loads. <p>Are all of the system electrical loads OFF?</p>	—	Go to Step 35	—
35	<p>The J 42000 automatically retests the battery. A RETESTING message and SYSTEM NOISE message on the display alternates up to 5 (Five) minutes while all circuits power down. The test results will then display on the tester.</p> <p>Are the test results displayed on the tester?</p>	—	Go to Step 14	Go to Step 36
36	<p>An undetected load or parasitic drain can cause the alternating RETESTING and SYSTEM NOISE messages to continue for more than 5 (Five) minutes.</p> <ol style="list-style-type: none"> Disconnect the J 42000 tester. Eliminate all electrical parasitic drains. Refer to <i>Battery Electrical Drain/Parasitic Load</i>. <p>Are all electrical loads and parasitic drains eliminated?</p>	—	Go to Step 2	—
37	<p>A J 42000 problem is indicated. Inspect the tester for correct operation.</p> <p>Is the tester operating properly?</p>	—	Go to Step 2	Go to Step 38
38	<p>Repair or replace the tester. Is the action complete?</p>	—	Go to Step 1	—
39	<p>A problem exists with the battery's built-in hydrometer (if applicable). Replace the battery. Refer to <i>Battery Replacement</i>.</p> <p>Is the action complete?</p>	—	System OK	—

Battery Electrical Drain/Parasitic Load

Current Drain Test

If the equipment exhibits a low or dead battery after an overnight period, or discharges over a period of 2 or 3 days and no cause is evident, the electrical system should be checked for an excessive electrical drain. The cause of the excessive unintended current drain is referred to as a parasitic load. One or more on-board solid-state control modules, such as the ECU, may at some time exhibit a failure mode that causes a high parasitic drain on the equipment's battery. Another source of parasitic drain could be an unnoticed load which remains on at all times.

Testing for a parasitic drain requires a special tool because the excessive current drain may not occur

after the battery is disconnected to install an ammeter. Cycling the ignition key to the RUN and then to the OFF position may cause such a drain to recur, but there may be drains that will not recur unless the equipment systems are reactivated in a use test. The ignition switch must not be rotated to the START position with an ammeter installed between the battery terminal and the battery cable, but the special tool enables the equipment to be run to assure that all equipment systems are ready for testing.

Tools Required

- J 38758 Draw Test Switch
- J 39200 Digital Multimeter, or equivalent

Notice: Always turn the ignition switch OFF when connecting or disconnecting batteries, battery chargers, or jumper cables. Failure to do so may damage the electronic control unit or other electrical components.

1. Disconnect the negative battery cable.
2. Ensure that the ignition switch is OFF, and that all electrical accessories are OFF.

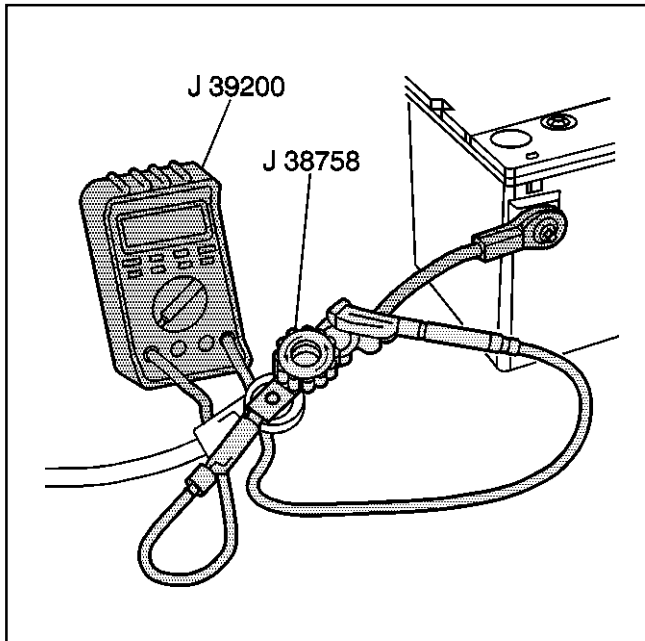

314656

3. Install the male end of the *J 38758* to the negative battery terminal.
4. Turn the *J 38758* test switch to the OFF position.
5. Connect the negative battery cable to the female end of the *J 38758* test switch.
6. Turn the *J 38758* test switch to the ON position.

Notice: Do not turn the parasitic draw test switch to the OFF position with the engine running. Damage will occur to the equipment's electrical system.

7. Test the electrical system by running the engine and operating the equipment.
8. Turn the ignition switch to the LOCK position and remove the key. Turn all electrical accessories off.
9. In order to avoid a false reading, wait 15 minutes for all components to power down before continuing this test.
10. Before connecting the ammeter, use the following procedure to determine whether or not the current drain is less than 10 amps:
 - 10.1. Connect a jumper wire with an in-line 10-amp fuse or circuit breaker to the terminals of the *J 38758* test switch.
 - 10.2. Turn the *J 38758* test switch to the OFF position.
 - 10.3. Wait 10 seconds.

11. If the fuse in the jumper wire does not blow, turn the *J 38758* test switch ON, set the *J 39200* to the 10-amp scale and connect the digital multimeter to the *J 38758* test switch, and then remove the jumper wire. If current is greater than 10 amps, use a test lamp instead of an ammeter.

Important: Always turn the *J 38758* test switch to the ON position between tests. The ON position allows current to flow through the battery cable. If the test switch is left in the OFF position between tests, the ammeter could be damaged due to accidental overloading.

12. Remove the fuses one at a time, and install each one after it is tested. Perform the following steps each time a fuse is removed:
 - 12.1. Turn the test switch to the OFF position which forces all current to flow through the meter.
 - 12.2. Wait at least 60 seconds. Check the current reading. If the reading is at or below 2 amps, turn the test switch to the ON position in order to maintain continuity in the electrical system while switching to the 2 amp scale for a more accurate reading. Turn the test switch to the ON position between tests.
 - 12.3. The parasitic draw is typically under 60 milliamperes. If the ammeter drops to an acceptable reading after a fuse is removed, the circuit causing the drain has been identified.
 - 12.4. Install the fuse for the circuit which is causing the excessive drain. Using the schematic as a guide, disconnect the components of the faulty circuit one at a time until the faulty component is located.
13. When the cause of excessive current draw has been located and repaired, remove the current drain test switch and connect the negative battery cable to the negative battery terminal.

Battery Hydrometer Displays Dark or Yellow Dot

The maintenance-free battery has a built-in hydrometer which consists of a ball floating in the electrolyte. The hydrometer is temperature-compensated. The color of the hydrometer indicates the condition of the battery.

- A green dot appearing on the hydrometer means that the battery is ready for testing.
- A dark hydrometer with no green visible means that the battery has a low charge.

Refer to *Charging System Check* or *Battery Electrical Drain/Parasitic Load*.

- A clear or light yellow color means that the battery fluid level is below the bottom of the hydrometer. Replace the battery if its condition affects the cranking system. A low fluid level can be caused by any of the following conditions:
 - An excessive charge
 - Tipping the battery
 - A faulty charging system. Refer to *Charging System Check*.

Battery Is Undercharged or Overcharged

Step	Action	Value(s)	Yes	No
1	1. Disconnect the generator connector. 2. Probe the generator connector with a digital multimeter from the generator BAT terminal to ground. 3. Measure the voltage. Does the voltage measure less than 10 volts?	10 V	Go to Step 2	Go to Step 3
2	Locate and repair the open in the wire between the starter solenoid S terminal and the generator BAT terminal. Is the repair complete?	—	System OK	—
3	1. Probe the generator connector with a digital multimeter from cavity S to ground. 2. Measure the voltage. Does the voltage measure less than 10 volts?	10 V	Go to Step 4	Go to Step 5
4	Locate and repair the open in the RED wire between the generator BAT terminal and generator connector cavity S. Is the repair complete?	—	System OK	—
5	1. Turn the ignition switch to the RUN position. 2. Probe the generator connector with a digital multimeter from cavity I to ground.. 3. Measure the voltage. Does the voltage measure less than 10 volts?	10 V	Go to Step 6	Go to Step 7
6	Locate and repair the open in the RED wire between the ignition switch terminal I and generator connector cavity I. Is the repair complete?	—	System OK	—
7	1. Turn the ignition switch to the OFF position. 2. Connect the generator connector. 3. Start the engine. 4. Run the engine at fast idle. 5. Probe the battery with a digital multimeter from the positive (+) terminal to the negative (-) terminal. 6. Measure the voltage. Does the voltage measure between 13-16 volts?	13-16 V	Go to <i>Battery Not Operating Properly</i> .	Go to Step 8
8	1. Do a Generator Bench Test. Refer to <i>Generator Assembly Bench Check</i> . 2. If the generator is OK, do a battery load test. Refer to <i>Battery Not Operating Properly</i> . Is the repair complete?	—	System OK	—

Engine Cranks/Cranks Slowly, But Does Not Start

Step	Action	Value(s)	Yes	No
1	Use a digital multimeter to measure the voltage of the battery. Is the voltage greater than or equal to the specified value?	12 V	Go to <i>Step 5</i>	Go to <i>Step 2</i>
2	1. Ensure the battery terminals and terminal bolts are free from corrosion. 2. Charge the battery. Refer to <i>Battery Charging</i> . 3. Disconnect the DIS ignition module connector. 4. Attempt to crank the engine. Does the engine crank normally?	—	Go to <i>Step 3</i>	Go to <i>Step 5</i>
3	1. Connect the DIS ignition module connector. 2. Verify that the charging system is operating correctly. Refer to <i>Charging System Check</i> . Is the charging system OK?	—	System OK	Go to <i>Step 4</i>
4	Repair the charging system. Is the repair complete?	—	System OK	—
5	1. Disconnect the DIS ignition module connector. Do not connect the DIS ignition module connector until all cranking tests are completed. 2. Turn the ignition switch to the START position. 3. Use a <i>J 39200</i> DMM to measure the voltage between the battery terminals while cranking the engine for 15 (fifteen) seconds. Notice: Never operate the starter motor for more than 15 seconds at a time. Allow it to cool at least two minutes before cranking again. Excessive cranking can cause overheating, which will cause serious damage to the starter motor. Does the voltage drop below the specified value while the starter is cranking the engine?	9.5 V	Go to <i>Step 6</i>	Go to <i>Step 9</i>
6	Load test the battery. Refer to <i>Battery Not Operating Properly</i> . Is the battery OK?	—	Go to <i>Step 8</i>	Go to <i>Step 7</i>
7	Replace the battery. Refer to <i>Battery Replacement</i> . Is the repair complete?	—	System OK	—
8	Replace the starter motor. Refer to <i>Starter Motor Replacement</i> . Is the repair complete?	—	System OK	—
9	Use a digital multimeter to measure the voltage between the battery negative (–) terminal and the engine block while cranking the engine. Notice: Never operate the starter motor for more than 15 seconds at a time. Allow it to cool at least two minutes before cranking again. Excessive cranking can cause overheating, which will cause serious damage to the starter motor. Is the voltage greater than the specified value?	0.5 V	Go to <i>Step 10</i>	Go to <i>Step 13</i>
10	1. Inspect the battery and negative (–) battery cable to determine if there is a high-resistance connection at either end. 2. Ensure that there is a clean connection between the starter mounting surface and the engine block. Was a high-resistance connection found?	—	Go to <i>Step 11</i>	Go to <i>Step 12</i>

Engine Cranks/Cranks Slowly, but Does Not Start (cont'd)

Step	Action	Value(s)	Yes	No
11	Repair the high-resistance connection. Is the repair complete?	—	System OK	—
12	Replace the negative (*) battery cable. Refer to <i>Battery Cable Replacement</i> . Is the repair complete?	—	System OK	—
13	1. Inspect the starter to determine if there is a high-resistance connection at the starter B terminal. 2. If the battery positive (+) terminal was not previously inspected, examine the positive (+) terminal and terminal bolt for corrosion which would indicate a high-resistance connection. Was there a high-resistance connection found?	—	Go to Step 14	Go to Step 15
14	1. Repair the high-resistance connection. 2. Connect the engine DIS ignition module connector. Is the repair complete?	—	System OK	—
15	Replace the positive (+) battery cable. Refer to <i>Battery Cable Replacement</i> . Is the repair complete?	—	System OK	—

Generator Noise Test

Generator noise may be caused by the following conditions:

- A loose drive pulley
- Loose mounting bolts
- Worn or dirty bearings
- A worn stator

- A worn rectifier bridge

If the pulley and the mounting bolts are snug and the noise continues, remove the generator for replacement or for inspection and repair. Refer to *Generator Replacement*.

Generator Not Operating Properly

Step	Action	Value(s)	Yes	No
NOTE: The following procedure is generic and applies to most commercial Charging System Testers. Read the instructions in the Operator's manual for the equipment before beginning this procedure.				
1	Perform the charging system check. Refer to <i>Charging System Check</i> . Has the charging system check been performed?	—	Go to Step 2	Go to <i>Charging System Check</i> .
2	Use a digital multimeter to check the voltage between the generator output (BAT) terminal and the generator metal case. Is the voltage above the specified value?	12 V	Go to step 6	Go to Step 3
3	Use a digital multimeter to check the voltage between the battery terminals. Is the voltage above the specified value?	12 V	Go to Step 5	Go to Step 4
4	1. Inspect the battery. Refer to <i>Battery Not Operating Properly</i> . 2. Charge or replace the battery if necessary. Is the battery OK?	—	Go to Step 7	—
5	1. Inspect the circuit between the generator output terminal and the battery positive (+) terminal for a loose connection or open circuit condition. 2. If a loose connection or open circuit was located, repair it. Is the circuit okay between the generator output terminal and the battery positive (+) terminal?	—	Go to Step 6	—
6	Repair the loose connection or open circuit between the battery negative (-) terminal and the generator housing. Is the repair complete?	—	Go to Step 7	—

Charging Time Required

The time required to charge a battery will vary. The time depends on the following factors:

- Size of the battery - A completely discharged heavy-duty battery requires more than twice the recharging time as a completely discharged light-duty battery.
- Temperature - Colder batteries require more time to recharge.
- Cold batteries accept only very low current at first during charging. The cold battery will accept a higher charging rate as the battery warms.
- Charger Capacity - A charger with higher amperage charges batteries in less time.
- State-Of-Charge - A completely discharged battery requires more than twice as much charge as a one-half charged battery.

The electrolyte in a completely discharged battery is nearly pure water, so the electrolyte is a very poor conductor. In this condition, the battery accepts very low current at first. Later, as the charging current increases the acid content of the electrolyte, the charging current also increases.

Any battery discharged by parasitic current drain, and then allowed to stand in this condition for a period of time, may not readily accept a charge. However, recharged long enough, many batteries will return to a usable condition.

Prolonged periods in a discharged state can result in permanent damage to the battery. This damage can accelerate under changing temperatures. Batteries that are extremely discharged can freeze at temperatures as high as -7°C (20°F). This results in permanent damage.

Disconnect the negative battery cable of equipment that is not going to be in service within a 30-day period. This will remove the constant drain on the battery. This can prevent damage to the battery and recharge problems. If this is not possible, recharge the battery every 30-45 days until the green dot is visible.

Battery Charge Low or Completely Discharged

Tools Required

J 39200 Digital Multimeter (DMM), or Equivalent

Caution: Refer to *Battery Cautions on page 3-9*.

Notice: Always turn the ignition OFF when connecting or disconnecting battery cables, battery chargers, or jumper cables. Failing to do so may damage the Electronic Control Module (ECU) or other electronic components.

Important: Tighten the adapters against the lead terminals of the battery in order to keep the resistance between the adapters and the battery terminals to a minimum.

Use the following procedure in order to recharge a very low or completely discharged battery. Carefully follow the procedure in order to avoid the replacement of a usable battery.

1. Measure the battery voltage at the battery terminals using the multimeter.
 - A reading of less than 11 volts indicates that the initial charging will be very low.
 - It could take some time before the battery accepts current in excess of a few milliamperes.
2. Set the battery charger on the high setting.
3. If necessary, disable the polarity protection circuitry.
 - This circuitry, available on most chargers, prevents charging unless the charger leads are properly connected to the battery terminals.
 - A completely discharged battery may not have enough voltage to activate this circuitry, even though the leads are properly connected, implying that the battery will not accept a charge.
 - Most chargers have an override or a bypass function so that the charger will turn ON and charge a low voltage battery.

Important: If the charging current is not measurable at the end of the charging time, replace the battery.

If the charging current is measurable during the charging time, the battery is good.

The required battery charge time varies according to the voltage capabilities of the battery charger. Charging time at various voltages may be as follows:

- 16.0 volts or more - up to 4 hours
 - 14.0-15.9 volts - 8 hours
 - 13.9 volts or less - 16 hours
4. In order to determine the amount of hours the battery may need to be charged, the following calculation can be made:
 - The reserve capacity rating on the battery label is the number of ampere-hours of charge required in order to produce the green hydrometer dot.
 - After the meter on the charger starts to show current flow, note the number of amps being accepted.
 - Determine the reserve capacity of the battery. Refer to *Battery Usage*.
 - Divide the reserve capacity by the number of amps shown on the meter in order to determine how many hours of charging is needed.
 5. When the green dot appears in the hydrometer, discontinue charging.
 6. If the green hydrometer dot is not visible after an ampere-hour charge equal to twice the reserve capacity rating, replace the battery. Refer to *Battery Replacement*.
 7. After charging, load test the battery. Refer to *Battery Not Operating Properly*.

Battery Replacement

Removal Procedure

Caution: Refer to *Battery Cautions on page 3-9*.

Notice: Always turn the ignition OFF when connecting or disconnecting battery cables, battery chargers, or jumper cables. Failing to do so may damage the Electronic Control Module (ECU) or other electronic components.

1. Disconnect the negative cable from the negative battery terminal.
2. Disconnect the positive cable from the positive battery terminal.
3. Remove the battery hold-down retainers.
4. Remove the battery.
5. Inspect the battery for damage.
6. Inspect the battery cables and the connections.
7. Inspect the carrier for damage or foreign objects. If damage is found, correct the cause.

Battery Replacement - Continued

Installation Procedure

1. Install the battery into the carrier.

Notice: Refer to *Fastener Notice* on page 3-2.

2. Install the battery hold-down retainers or the top bars.

Tighten

Tighten the retainer bolt to 18 N•m (13 lb ft). Tighten the top bar nut to 10 N•m (89 lb in).

3. Install the positive (+) battery cable to the battery.

Tighten

Tighten the battery side terminal bolts (if applicable) to 12 N•m (106 lb in).

Tighten the top terminal nuts (if applicable) to 18 N•m (13 lb ft).

4. Install the negative (-) battery cable to the battery.

Tighten

Tighten the battery side terminal bolts (if applicable) to 12 N•m (106 lb in).

Tighten the top terminal nuts (if applicable) to 18 N•m (13 lb ft).

Jump Starting in Case of Emergency

Do not try to jump start equipment if you are unsure of the voltage or ground of the other equipment, or if the voltage and ground of the other equipment is different.

Be careful of the booster battery and the discharged battery when using jumper cables. Be careful in order to avoid causing sparks.

Notice: To protect the electronic control module, do not jump the battery with "Hot Shot" (over 14 V) charging aids. Do not disconnect the battery while the engine is running to verify charging system operation.

Jump Starting Procedure

Caution: Refer to *Battery Cautions* on page 3-9.

Notice: Always turn the ignition OFF when connecting or disconnecting battery cables, battery chargers, or jumper cables. Failing to do so may damage the Electronic Control Module (ECU) or other electronic components.

1. If equipped, check the built-in hydrometer. If the hydrometer is clear or light yellow (3), do not jump start the battery. Replace the battery. Refer to *Battery Replacement*.
2. Ensure the jumper cables do not have loose or missing insulation.
3. Position the equipment with the booster (good) battery so that the jumper cables will reach, but DO NOT let the equipment touch.
4. Connect one jumper cable to the positive terminal of the booster battery and the positive terminal of the discharged equipment.
5. Attach one end of the other jumper cable to the negative terminal of the booster battery.
6. Attach the remaining end of the jumper cable to a solid ground at least 450 mm (18 in) from the booster battery.
7. Start the engine of the equipment with the booster battery. Turn off all electrical accessories.
8. Start the engine of the equipment with the discharged battery.
9. Disconnect the jumper cable from the ground.
10. Disconnect the other end of the jumper cable from the negative terminal of the booster battery.
11. Remove the jumper cable connecting the positive terminals.

Starter Motor Inspection

Cleaning Procedure

Notice: Do not use grease dissolving solvents for cleaning the overrunning clutch or armature. Solvents dissolve the grease packed in the clutch and damage the armature and the field coil insulation.

Clean all starter motor parts with a soft cloth prior to testing.

Inspection Procedure

Inspection in the following steps refers to visual inspection of the starter motor parts and assemblies in order to determine the serviceability of the parts.

1. Inspect all parts for cracks, distortion, or other structural damage. Replace parts and assemblies that are cracked, bent, or otherwise damaged.
2. Inspect the threaded parts for stripped, crossed, or otherwise damaged threads. Replace parts as necessary.
 - Replace the parts with thread damage that cannot be cleaned up using a suitable tap or die.
 - Replace any hardware items that have damaged threads.
3. Inspect the solenoid assembly for a cut or torn boot. If the boot is damaged, replace the solenoid assembly.
4. Inspect the clutch drive assembly. Replace the clutch drive assembly as necessary. Look for the following damage:
 - The pinion gear turns roughly or turns in both directions.
 - The pinion gear teeth are broken or show evidence of step wear.
 - The shift lever collar shows deep scoring or other damage.

Component Electrical Testing

Perform the following electrical tests in order to determine the serviceability of the starter assemblies.

1. Using an ohmmeter, check the windings of the solenoid assembly for continuity using the following procedure:
 - Check the resistance of the solenoid pull-in and hold-in windings in a series by measuring the resistance between the motor terminal and the solenoid case.
 - A resistance reading well above 1.95 ohms indicates a break or fault in the winding continuity.
 - A resistance reading well below 1.95 ohms indicates a short or ground in the winding circuit.
 - Replace the solenoid assembly if the resistance reading is extremely high or very low.
2. Check the armature for shorts, opens and grounds using the following procedure. Replace armature if it is shorted, grounded, or has any evidence of an open circuit.
 - 2.1. Rotate the armature in a growler.
 - 2.2. Hold a steel strip such as a hacksaw against the armature.
 - 2.3. If the steel strip vibrates in an area, a short is present.
 - Using a self-powered test lamp or ohmmeter, check for continuity between the armature shaft and any point on the commutator. Continuity indicates a ground.
 - Inspect the points where the armature conductors join the commutator for signs of arcing or burning. These signs indicate opens.

Armature Bearing Replacement

Notice: Ball bearings that are removed from the armature must be replaced with new bearings. The removal procedure causes internal damage to the bearings.

Removal Procedure

Remove the commutator end or drive end bearings from the armature assembly using a suitable bearing puller.

Installation Procedure

1. Install the new commutator end and/or drive end bearings to the armature assembly using a tube that bears only on the bearing inner race.
2. Press on the bearing until the inner race bottoms out against the shoulder of the armature shaft.

Starter Motor Replacement

Removal Procedure

Notice: Never operate the starter motor more than 15 seconds at a time without pausing to allow it to cool for at least 2 minutes. Overheating, caused by excessive cranking, will damage the starter motor.

Starter motors do not require lubrication except during overhaul.

Caution: Refer to *Battery Cautions on page 3-8*.

1. Disconnect the negative (-) battery cable.
2. Disconnect the wires and the positive (+) battery cable from the starter solenoid.
3. Remove the mounting bolt, stud and the washers that hold the starter to the engine.
4. Remove the starter and shims (if present) from the engine.
5. Remove the starter shield, if equipped.

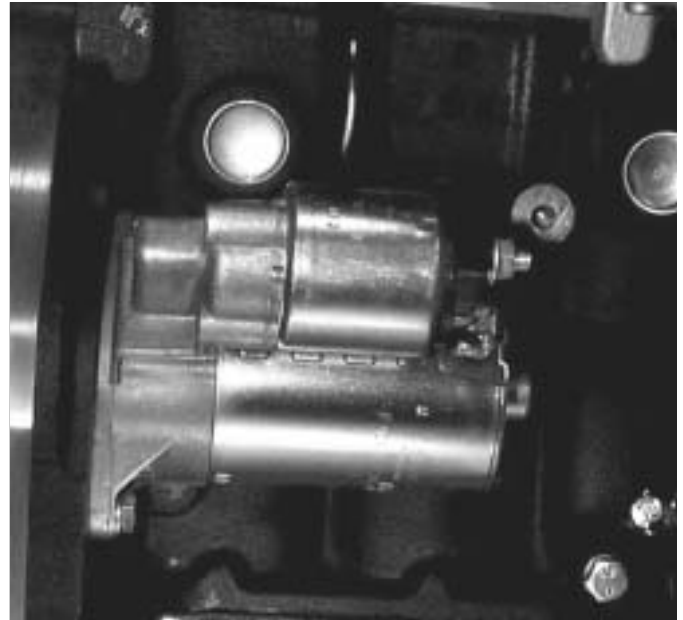

80363003

Installation Procedure

1. Install the shield to the starter motor, if equipped.
2. Position the starter motor and shims (if used) on the engine.

Notice: Refer to *Fastener Notice on page 3-2*.

3. Install the mounting bolt, stud, and washers.

Tighten

Tighten the starter bolt and stud to 25 N•m (18 lb ft).

3. Install the positive (+) battery cable and wires to the starter solenoid with the nut.

Tighten

- Tighten the battery positive (+) cable starter solenoid nut to 15 N•m (11 lb ft).
- Tighten the S terminal nut to 6.5 N•m (55 lb in).

5. Install the negative (-) battery cable to the battery.

Tighten

- Tighten the battery side terminal bolts (if applicable) to 12 N•m (106 lb in).
- Tighten the top terminal nuts (if applicable) to 18 N•m (13 lb ft).

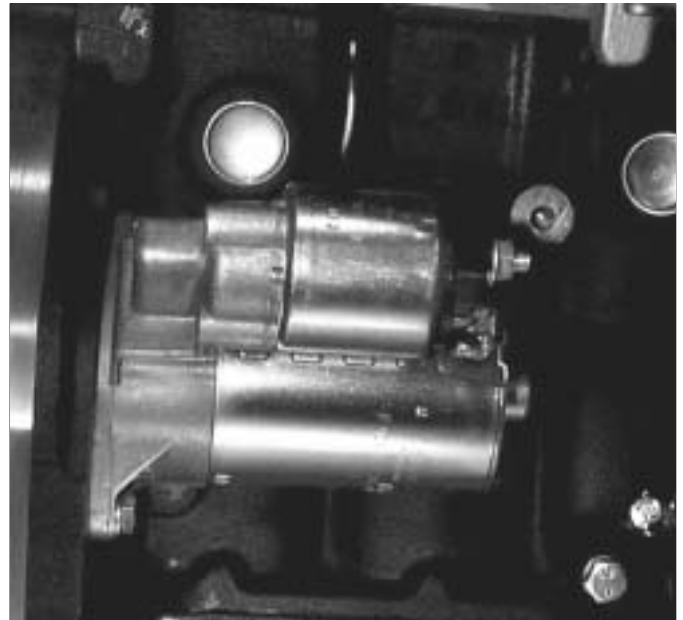

80363003

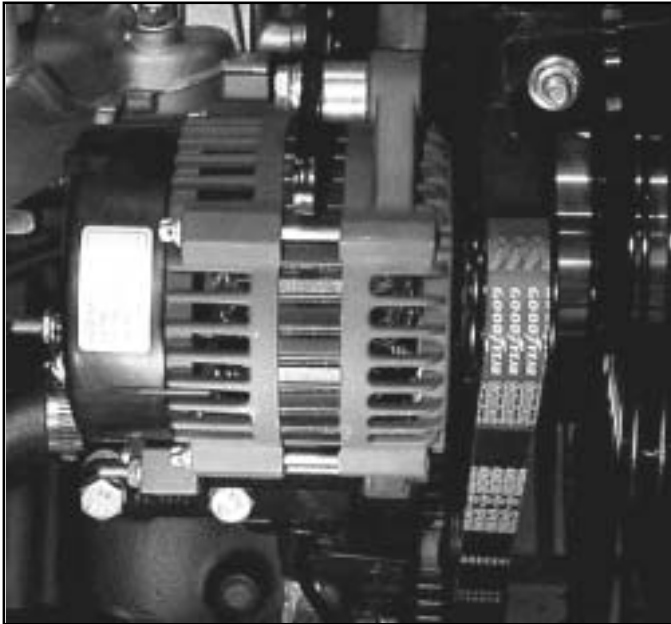

80363002

Generator Replacement

Removal Procedure

The removal and installation instructions serve only as a guide. Additional operations may be required on some equipment to remove other equipment in order to gain access to the generator, the drive belt, and the brackets.

Caution: Failure to observe Step 1 in this procedure may result in an injury from the live battery lead at the generator.

Caution: Refer to Battery Cautions on page 3-8.

1. Disconnect the negative (-) battery cable.
2. Disconnect the electrical connectors from the generator.
3. Disconnect the battery lead from the back of the generator.
4. Disconnect the generator ground wire.
5. Remove the drive belt. Refer to *Drive Belt Replacement* in Engine Cooling.
6. Remove the upper generator mounting bolt.
7. Remove the lower generator mounting bolt and nut.
8. Remove the generator from the generator mounting bracket.

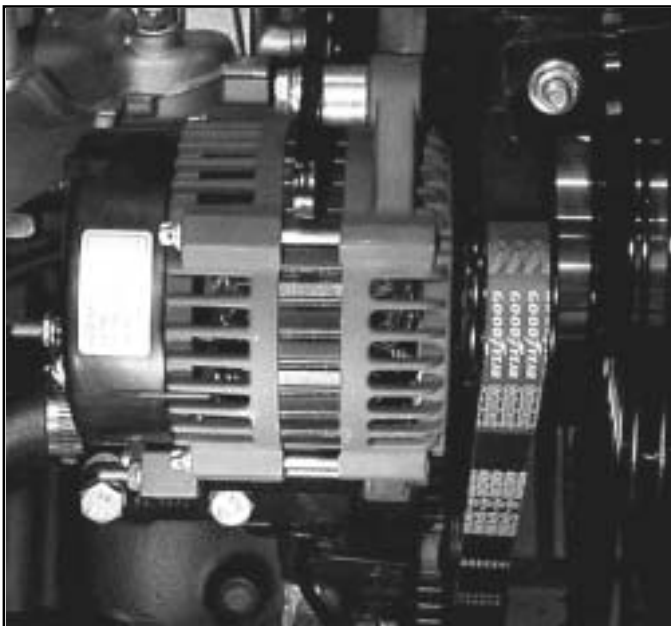

80363002

Installation Procedure

1. Install the generator into the generator mounting bracket.

Notice: Refer to *Fastener Notice* on page 3-2.

2. Install the generator mounting bolts.

Tighten

- Tighten the top mounting bolt to 20 N•m (15 lb ft).
- Tighten the bottom mounting bolt and nut to 35 N•m (26 lb ft).

3. Install the drive belt. Refer to *Drive Belt Replacement* in Engine Cooling.
4. Install the generator ground wire.
5. Connect the electrical connectors to the generator.
6. Connect the battery lead to the back of the generator.

Tighten

Tighten to battery terminal nut to 8 N•m (71 lb in).

7. Connect the negative (-) battery cable to the battery.

Tighten

Tighten the battery side terminal bolts (if applicable) to 12 N•m (106 lb in).

Tighten the top terminal nuts (if applicable) to 18 N•m (13 lb ft).

DIS Ignition Module Replacement

Removal Procedure

1. Noting their positions, remove the spark plug wires from the module.
2. Disconnect the engine wiring harness connector from the module.
3. Remove the three module mounting bolts.
4. Remove the module from the camshaft housing.

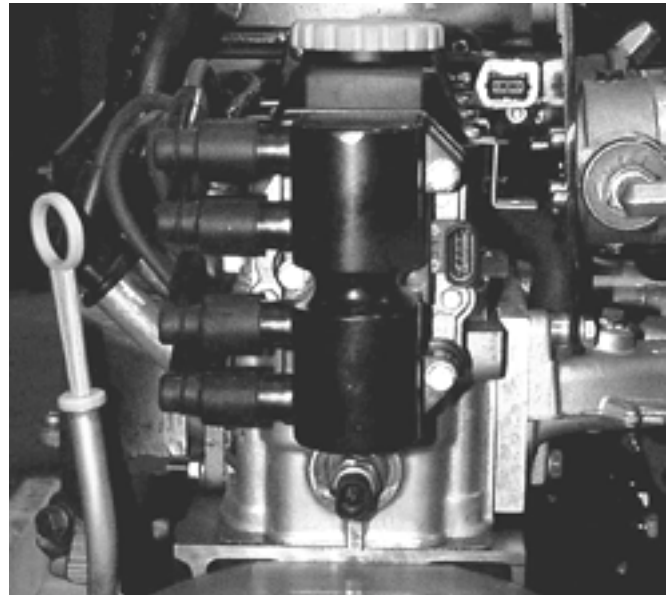

80363005

Installation Procedure

1. Position the module on the camshaft housing.
2. Install the three module mounting bolts.

Tighten

Tighten the mounting bolts to 8 N•m (71 lb in).

3. Connect the engine wiring harness connector to the module.
4. Install the spark plug wires to the module in the same positions noted during removal.

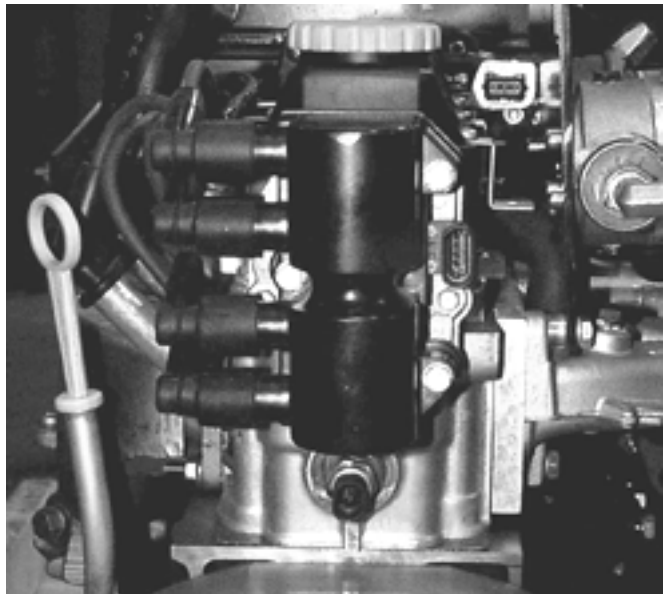

80363005

Setting Ignition Timing

The PSI 1.6L engine has a distributorless ignition system (DIS). The ignition timing adjustments are controlled by the Electronic Control Unit, or ECU.

A timing indicator and timing marks are still visible at the crankshaft pulley, but are not used to set or adjust ignition timing.

Crankshaft Position (CKP) Sensor Replacement

Removal Procedure

1. Disconnect the engine wiring harness connector from the crankshaft position sensor pigtail.
2. Remove the crankshaft position sensor pigtail from the camshaft housing cover bracket.



80363006

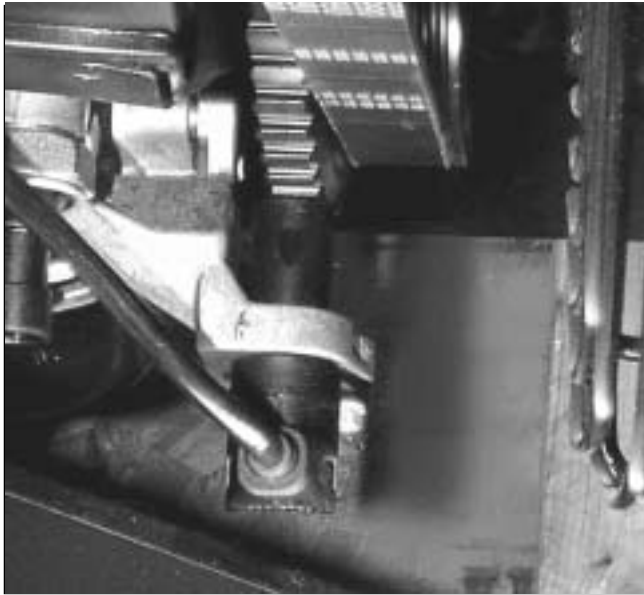

80363007

3. Remove the sensor mounting bolt.
4. Noting the pigtail routing, remove the sensor and pigtail from engine.

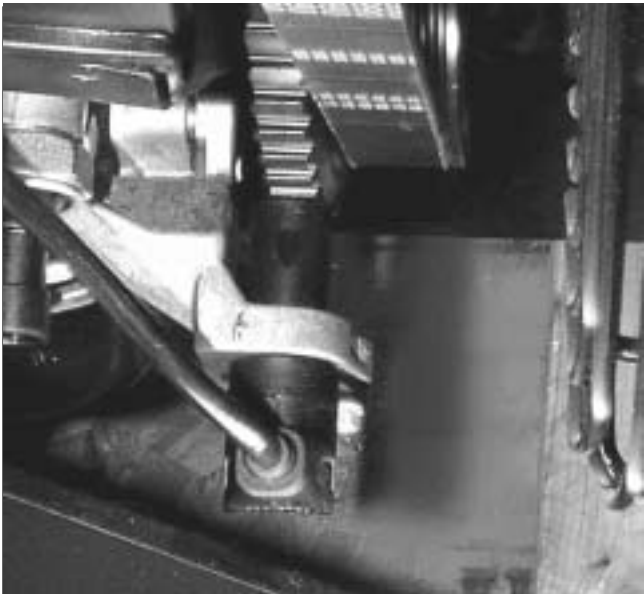

80363007

Installation Procedure

1. Position the crankshaft position sensor in its mounting bracket.
2. Install the sensor mounting bolt.

Tighten

Tighten the mounting bolt to 8 N•m (71 lb in).



80363006

3. Following the routing noted during removal, route the pigtail and snap it into the bracket on the camshaft housing cover.
4. Connect the engine wiring harness connector to the crankshaft position sensor pigtail.
5. Measure distance between crankshaft position sensor and the reluctor wheel with a feeler gauge.

Specification: 0.3-1.5 mm. (0.012-0.059 in.)
6. If the gap is incorrect, replace the crankshaft position sensor bracket.

Description and Operation

Starting System Description

Cranking Circuit

The cranking circuit consists of the following components:

- The battery
- The starter motor
- The ignition switch
- All related electrical wiring

For detailed schematics of the starting system refer to *Schematic and Routing Diagrams*.

Starter Motor

The 1.6 liter 4-cylinder engine uses a Bosch starter motor that is considered repairable.

The starter has an over running roller-type clutch and an enclosed shift lever. The solenoid is sealed in order to prevent entry of foreign material. The part number is stamped on a label attached to the field frame.

The shift lever mechanism and the solenoid plunger are enclosed in the drive housing in order to protect them from exposure to dirt, icing conditions, and splash.

The solenoid windings energize when the ignition switch is in the START position. The resulting plunger and the shift lever movement causes the pinion to mesh with the engine flywheel ring gear, the solenoid main contacts close, and the engine cranking takes place. When the engine starts, the pinion overrunning clutch protects the armature from excessive speed until the ignition switch is released, at which time the plunger return spring causes the pinion to disengage. In order to prevent excessive overrunning, release the ignition switch immediately when the engine starts.

Starting System Circuit Description

Battery voltage is applied at all times to the starter solenoid B (battery) terminal through the positive battery cable.

When the ignition switch is turned to the START position, battery voltage is applied from the closed contacts of the ignition switch to S terminal of the starter solenoid through the BLUE wire.

With voltage applied to the starter solenoid S terminal, current flows through the hold-in coil to the mechanical ground at the solenoid. At the same time, current flows through the pull-in coil and the starter motor to the starter motor's mechanical ground. The combined magnetic force of the coil windings overcomes the force of the return spring to pull in and hold in the plunger. The plunger moves the shift lever. This causes the drive assembly to engage with the engine flywheel.

The plunger actuation also operates a contact within the starter solenoid which closes to apply battery voltage directly to the starter motor. The starter motor now cranks the engine.

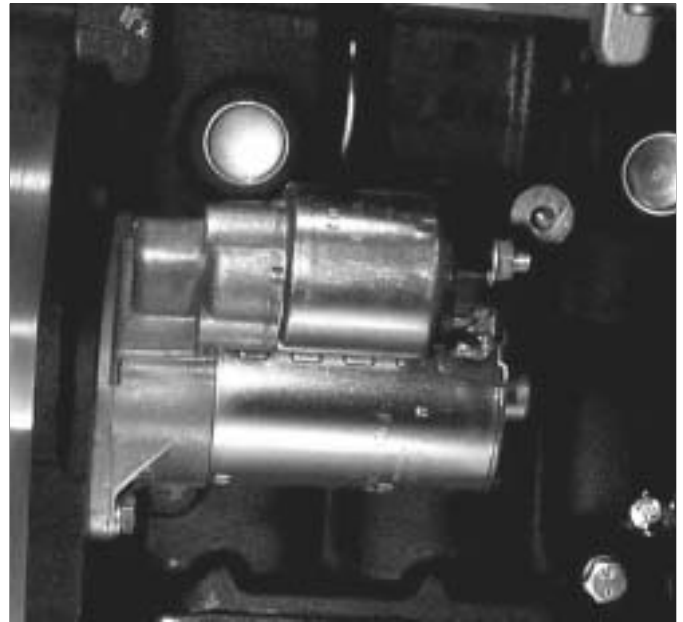

80363003

With battery voltage applied directly to the starter motor, the pull-in coil now has voltage applied to both ends of the coil and current ceases to flow. The starter solenoid remains engaged due to the current flow through the hold-in coil alone. The starter motor continues to operate until the ignition switch is returned to the RUN position.

With the ignition switch in the RUN position, voltage is removed from the starter solenoid S terminal. Voltage is applied at the solenoid B terminal, so both coils are still energized by battery voltage through the closed motor contacts. However, the forces from these coil windings now oppose one another and the plunger returns to the disengaged position through the operation of the return spring. This opens the contact within the solenoid to remove battery voltage from the starter motor and the motor stops. Both coils also de-energize. This plunger operation also retracts the starter drive assembly from the flywheel and the engine operates on its own power.

Batteries

PSI does not supply batteries to equipment manufacturers. However, on the previous pages, you will find some generic methods used to diagnosis common battery problems. You may need to contact the equipment manufacturer for specific procedures and specifications for the battery you are working with.

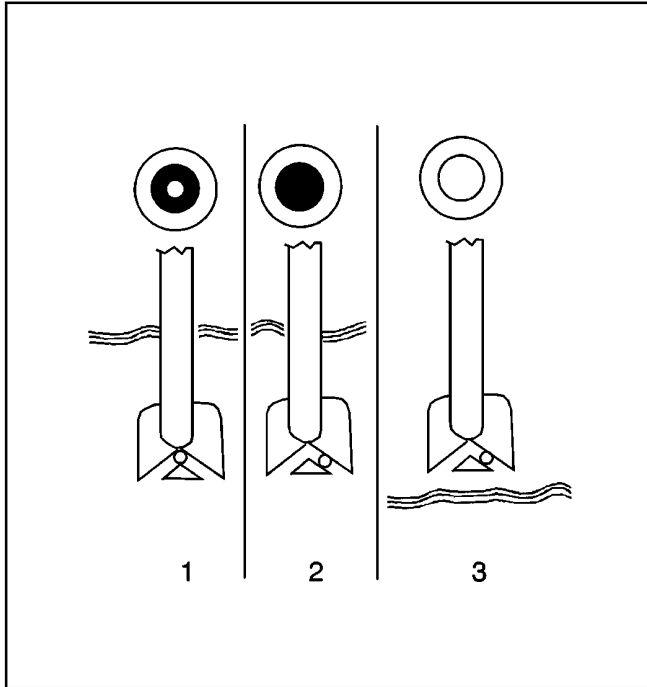

181056

Built-in Hydrometer-If Equipped

A built-in temperature compensation hydrometer is molded into the top of some maintenance free batteries. When observing the hydrometer, make sure the battery top is clean. Use a light in poorly-lit areas. Under normal operating conditions, one of three indications can be observed:

1. Any green appearance in the hydrometer is interpreted as a green dot. This means the battery is ready for testing.
2. A dark dot is visible. If the green dot is not visible and there is a complaint about cranking, refer to *Battery Not Operating Properly* or *Battery Electrical Drain/Parasitic Load*.
3. A clear or light yellow dot means the electrolyte level is below the bottom of the hydrometer and is too low for diagnosis. When you find a battery in this condition, this may indicate high charging voltages caused by a faulty charging system. Because of this, the charging and electrical systems must be checked. Refer to *Charging System Check*. The yellow dot may have been caused by the following conditions:
 - Excessive or prolonged charging
 - A broken case
 - Excessive tipping
 - If the battery has a yellow or clear hydrometer, replace the battery if a cranking complaint exists.

Charging System Description

The charging system consists of the following components:

- The battery
- The generator
- The voltmeter gauge
- All related electrical wiring

The generator supplies the electrical power for charging the battery and for operating the accessories.

SI-Series Generators

All PSI 1.6L industrial engines use a Delco-Remy Diode Rectified AC generator. Since these units have an integral voltage regulator, they are referred to as a System Integral Charging Unit, or "SI" for short.

The 1.6L engine uses a model 7-SI which provides the proper current output (up to 70 amperes) to meet the needs of various industrial applications.

A terminal marked "P" on the rear of the generator is available to provide a speed input to the tachometer, if needed.

The generator has an internal regulator and does not have a diode trio. The delta stator (1), the rectifier bridge (4), and the rotor with slip rings and brushes (3), are electrically similar to other Delco-Remy generators. The generator uses a conventional fan and pulley. An internal fan cools the slip rings, the end frame, the rectifier bridge, and the regulator. The voltmeter gauge indicates the battery's state of charge in DC volts when the ignition switch is in the RUN position and the engine is not running.

When the engine is running, the voltmeter indicates the condition of the charging system. Indications between the low and high warning zones represent the normal operating range. Readings in the low warning zone may occur when a large number of electrical accessories are operating in the vehicle and the engine is left at an idle for an extended period. This condition is normal since the charging system is not able to provide full power at engine idle.

As engine speeds are increased, this condition should correct itself as higher engine speeds allow the charging system to create maximum power. Continuous readings in either warning zone indicate problems if any of the following conditions occur:

- Any abnormal charging condition
- System voltage is too high or too low

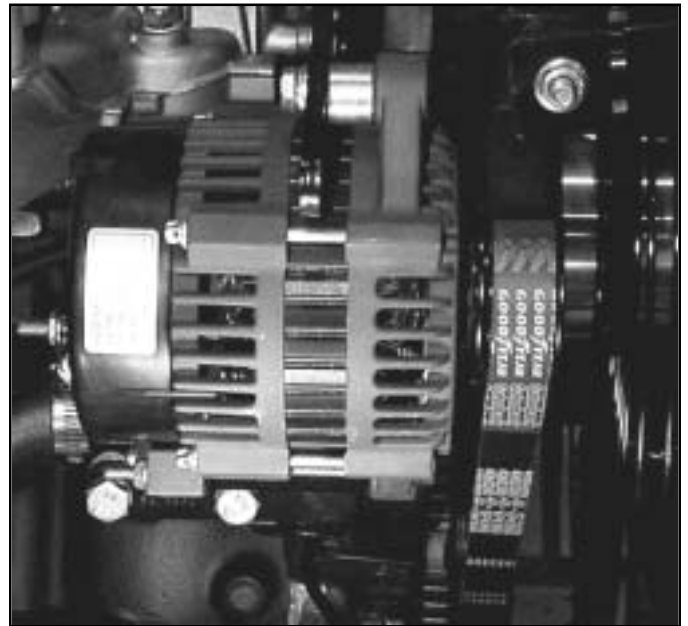

80363002

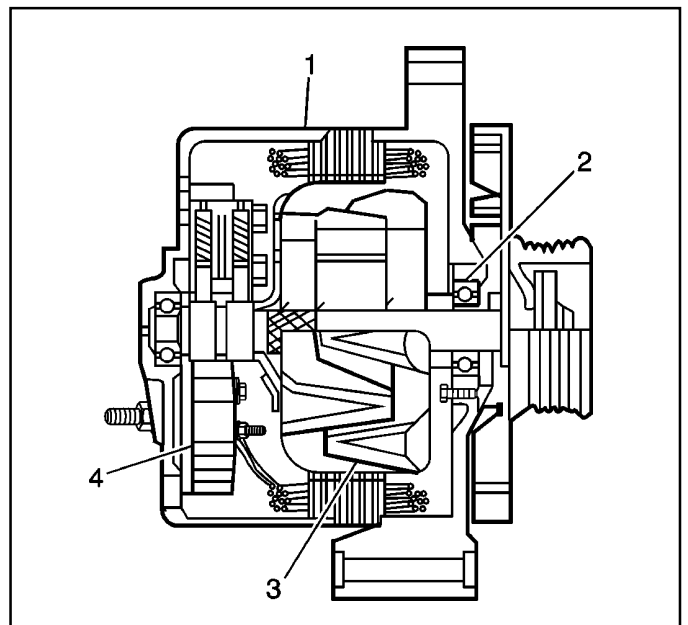

181768

Voltage Regulator

The integral voltage regulator protects the unit's operating accessories from receiving high voltage and the battery from being overcharged. No current regulation is needed because it is determined by the design of the generator.

The regulator is an extremely reliable device composed of two circuits. One of these circuits is used to sense voltage and control the other circuit which cycles the field current "on and off" to prevent voltage from going too high.

The regulator limits system voltage by controlling the rotor field current. When the field current is on, the regulator switches the rotor field on and off at a fixed rate of about 400 cycles per second. By varying the overall on/off time, correct average field current for proper system voltage control is maintained. At high speeds, the on time may be 10 percent and the off time may be 90 percent. At low speeds, and with high electrical loads, the on/off time may be 90 percent and 10 percent respectively.

The regulator has four terminals, The terminals are P, L, I, and S. These letters are stamped on the regulator.

Generally, in SI generators the S terminal senses the state of the battery and allows field current flow when the switch is closed.

When the battery voltage rises to a predetermined level, the sensing circuit tells the regulator to turn OFF. This decreases the magnetic field around the field coil and generator voltage is limited to a safe value.

When the battery voltage drops below a predetermined level, the sensing circuit tells the regulator to turn ON. This increases the magnetic field around the field coil and generator voltage begins to charge the battery.

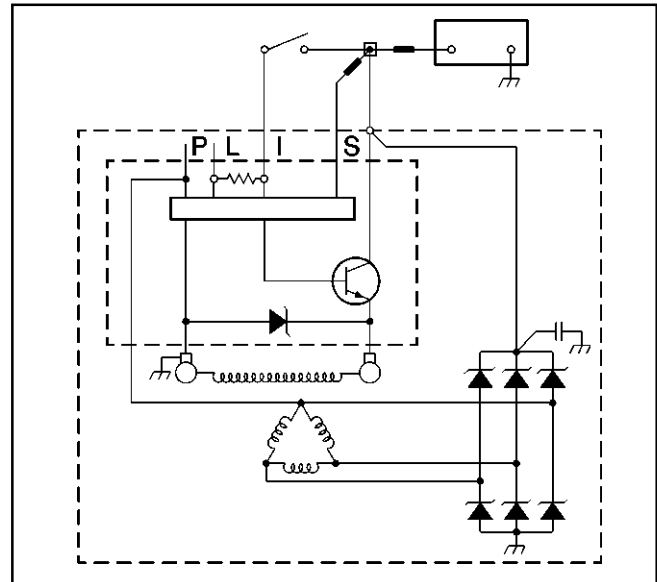

375662

Charging System Circuit Description

The generator provides voltage that operates the electrical system of the vehicle and that also charges the battery and the secondary battery. A magnetic field is created when current flows through the rotor. The field rotates as the rotor is driven by the engine, creating an AC voltage in the stator windings. The rectifier bridge converts the AC voltage to DC and this goes to the electrical system at the terminal to the battery.

The digital regulator of the generator uses digital techniques in order to supply the rotor current. Because of this, the digital regulator controls the output voltage. The rotor current is proportional to the width of the electrical pulses supplied from the electrical system through the RED wire connected between the battery and S terminals on the generator.

When the ignition switch is turned to the RUN position, current from the battery flows through the closed contacts of the switch, to the voltmeter gauge on the instrument panel, the voltage regulator, and through the field coil of the generator rotor.

With current applied to the digital regulator, the regulator turns on. Narrow width pulses go to the digital rotor circuit, creating a weak magnetic field. When the engine starts, the digital regulator senses the rotation of the generator by detecting AC voltage at the stator through an internal wire. Once the engine is running, the digital regulator varies the field current by controlling the pulse width. This regulates the output voltage of the generator for proper charging of the battery and operation of the electrical system.

IGNITION SYSTEM DESCRIPTION

The 1.6 Liter, 4-cylinder engine, is equipped with a distributorless ignition system (DIS). The electronic control unit (ECU) performs all of the ignition control functions based on signals from the crankshaft position sensor.

The ignition system consists of a battery, the DIS ignition module containing two coil packs, a crankshaft position sensor, an ignition switch, the spark plugs, and the primary and secondary ignition wiring.

Ignition Switch

The ignition switch mounting location is determined by the customer. The switch has three terminals. The "B" (battery) terminal is connected directly to the battery and is "hot" at all times. The "I" (ignition) terminal is "hot" when the switch is in the RUN or START positions. This terminal provides current to the ignition system and the engine electrical components such as the generator field circuit. The "S" terminal is "hot" in START only. It provides current to energize the starter solenoid, allowing the starter motor to operate.

DIS Ignition Module

The DIS ignition module contains two ignition coil packs and is mounted at the rear of the camshaft housing. It is powered by an ignition feed or primary circuit. Battery voltage is available at the primary ignition terminal "D" of the module anytime the ignition switch is in the RUN or START position and terminal "C" provides a dedicated ground.

The secondary circuit is connected to the module and spark plugs by a high tension wires.

The DIS ignition module is controlled by pulses provided by the ECU. The ECU causes a spark to occur by pulsing an IC circuit, which triggers an ignition coil and fires the appropriate spark plug.

One ignition coil pack fires cylinders 1 and 4 while the other coil pack fires cylinders 2 and 3.

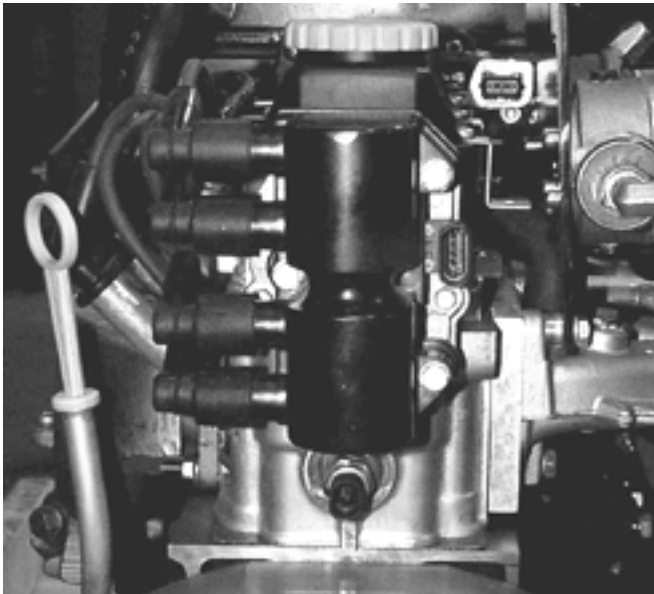

80363005

Spark Plugs

The 1.6 Liter engine uses resistor type spark plugs. The plugs used in this engine have a tapered seat, so a gasket is not required.

A spark plug must operate within certain temperature limits to provide the performance and service life expected. The plug selected for this engine is based on the normal service for which the engine was designed. Depending on operating conditions, the spark plug heat range may have to be adjusted upward or downward one range in order to match the specific engine requirements.

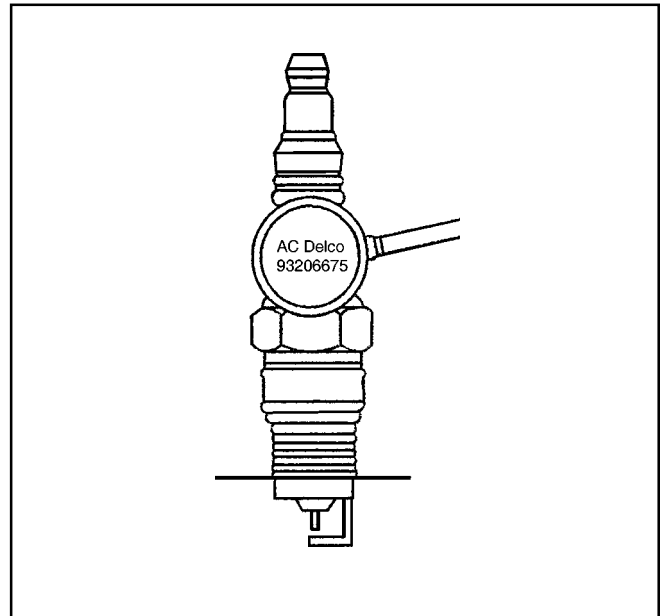

80363008

Secondary Wiring

The secondary wires, often referred to as "spark plug wires", carry voltage between the ignition coil packs and the spark plugs.

The secondary wiring used with the 1.6 Liter engine is a carbon impregnated cord conductor encased in an 8 mm (5/16-inch) diameter silicone rubber jacket. The silicone wiring will withstand very high temperatures and also provides an excellent insulator for the higher voltages of a distributorless ignition system.

The secondary wire connections are covered with rubber boots and form a tight seal to prevent arcing.

Notice: Because the secondary wires are designed for a tight fit, always remove the wires by pulling on the boot while exerting a gentle twisting action. This will prevent damage to the wire connectors. Pulling directly on the spark plug wires can damage them.

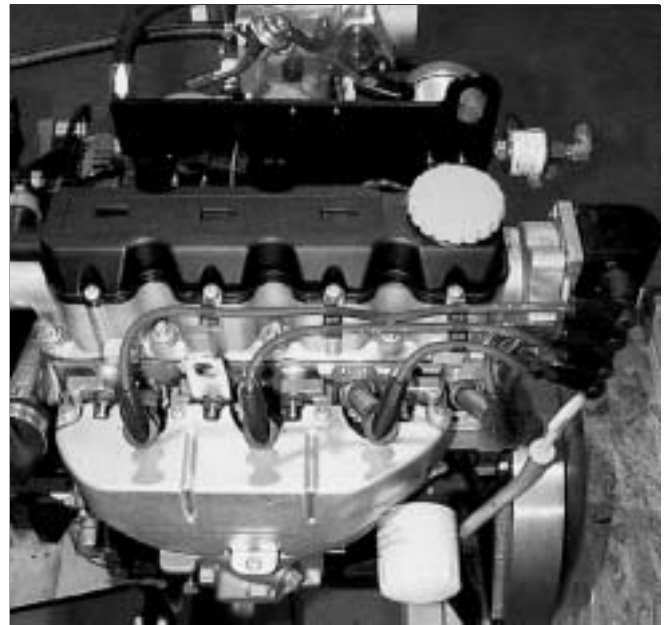

80363004

Crankshaft Position (CKP) Sensor

The crankshaft position (CKP) sensor is located at the lower right front of the engine, near the crankshaft pulley.

The sensor works in conjunction with a 58 tooth reluctor wheel on the crankshaft. The electronic control unit (ECU) monitors the voltage from the CKP sensor circuits.

As the reluctor wheel tooth passes past the sensor, the sensor creates an analog voltage signal. This analog signal is used by the ECU to properly synchronize the fuel injectors and the ignition timing.

On some engine applications, this signal can also be used to detect engine misfires.

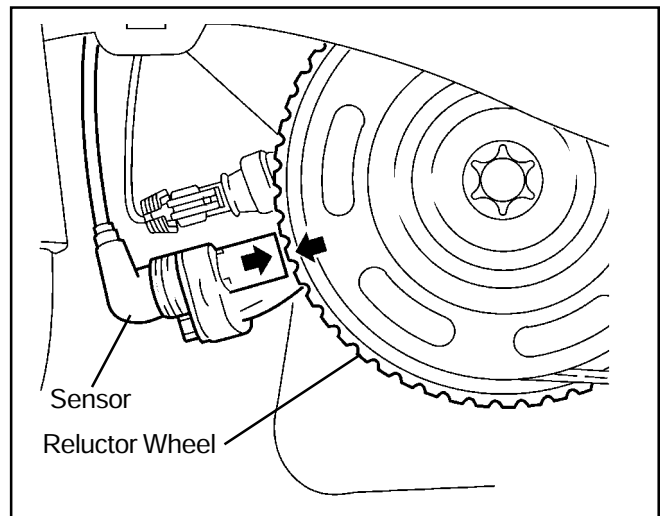

80363009

Special Tools and Equipment

NOTE: The diagnostic tools shown here are available from Kent-Moore. However, equivalent tools supplied by other manufacturers are permissible for use.

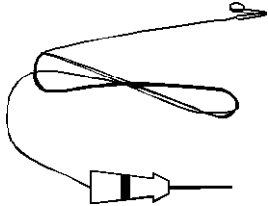
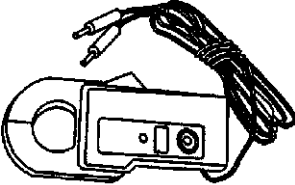
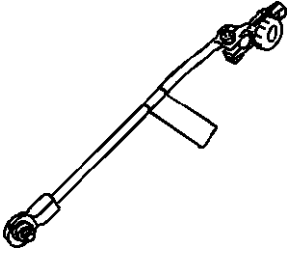
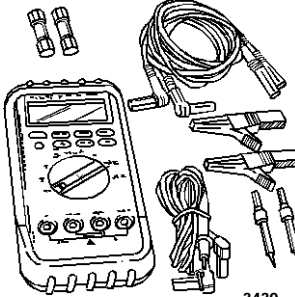
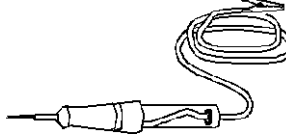
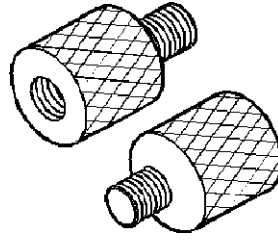
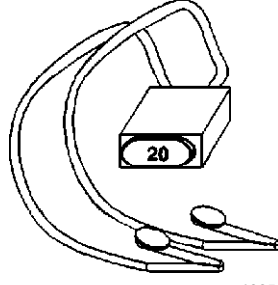
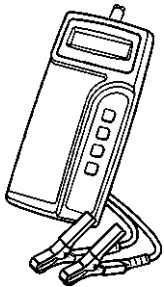
Illustration	Tool Number/Description
 <p>8439</p>	<p>J 21008 -A Self-Powered Test Light</p>
 <p>95591</p>	<p>J 35590 Current Clamp</p>
 <p>3432</p>	<p>J 38758 Parasitic Draw Test Switch</p>
 <p>3430</p>	<p>J 39200 Digital Multimeter</p>

Illustration	Tool Number/Description
 <p>5382</p>	<p>J 34142-B Unpowered Test Light</p>
 <p>3431</p>	<p>P/N 12303040 Battery Terminal Adapters</p>
 <p>1025</p>	<p>J 36169-A Fused Jumper Wire</p>
 <p>404758</p>	<p>J 42000 Battery Load Test Tool</p>